



NEW ZEALAND

EDICT OF GOVERNMENT

In order to promote public education and public safety, equal justice for all, a better informed citizenry, the rule of law, world trade and world peace, this legal document is hereby made available on a noncommercial basis, as it is the right of all humans to know and speak the laws that govern them.

AS-NZS 3500-3 (2003) (English): Plumbing and drainage - Part 3: Stormwater drainage [By Authority of New South Wales Code of Practice - Plumbing and Drainage]

*We will sell to no man,
we will not deny or defer to any man either justice or right.*

Magna Carta—Tūtohingā Nui

*Kore rawa e hoko ki te tangata, e kore e whakakāhoretia,
e tautuku rānei te tangata ki te ture, tika ranei.*



BLANK PAGE



AS/NZS 3500.3:2003

This Joint Australian/New Zealand Standard was prepared by Joint Technical Committee WS-014, Plumbing and drainage. It was approved on behalf of the Council of Standards Australia on 10 November 2003 and on behalf of the Council of Standards New Zealand on 19 November 2003.
This Standard was published on 15 December 2003.

The following are represented on Committee WS-014:

Association of Accredited Certification Bodies
Association of Consulting Engineers Australia
Association of Hydraulic Services Consultants Australia
Australian Industry Group
Australian Steel Institute
Building Officials Institute of New Zealand
Business New Zealand
Department of Infrastructure, Energy and Resources (Tasmania)
Engineers Australia
Housing Industry Association
Master Plumbers, Gasfitters and Drainlayers New Zealand
Plastics Industry Pipe Association of Australia
Plastics New Zealand
Plumbing Industry Commission

Keeping Standards up-to-date

Standards are living documents which reflect progress in science, technology and systems. To maintain their currency, all Standards are periodically reviewed, and new editions are published. Between editions, amendments may be issued. Standards may also be withdrawn. It is important that readers assure themselves they are using a current Standard, which should include any amendments which may have been published since the Standard was purchased.

Detailed information about joint Australian/New Zealand Standards can be found by visiting the Standards Web Shop at www.saiglobal.com.au or Standards New Zealand web site at www.standards.co.nz and looking up the relevant Standard in the on-line catalogue.

For more frequent listings or notification of revisions, amendments and withdrawals, Standards Australia and Standards New Zealand offer a number of update options. For information about these services, users should contact their respective national Standards organization.

We also welcome suggestions for improvement in our Standards, and especially encourage readers to notify us immediately of any apparent inaccuracies or ambiguities. Please address your comments to the Chief Executive of either Standards Australia or Standards New Zealand at the address shown on the back cover.

This Standard was issued in draft form for comment as DR 03198.

AS/NZS 3500.3:2003
(Incorporating Amendment Nos 1 and 2)

Australian/New Zealand Standard™

Plumbing and drainage

Part 3: Stormwater drainage

Originated as part of AS CS 3—1931.
Previous edition AS/NZS 3500.3.2:1998.
Jointly revised and redesignated as AS/NZS 3500.3:2003.
Reissued incorporating Amendment No. 1 (July 2006).
Reissued incorporating Amendment No. 2 (March 2010).

COPYRIGHT

© Standards Australia/Standards New Zealand

All rights are reserved. No part of this work may be reproduced or copied in any form or by any means, electronic or mechanical, including photocopying, without the written permission of the publisher.

Jointly published by Standards Australia, GPO Box 476, Sydney, NSW 2001 and Standards New Zealand, Private Bag 2439, Wellington 6140

ISBN 0 7337 5604 2

PREFACE

This Standard was prepared by the Joint Standards Australia/Standards New Zealand Committee WS-020, Stormwater, to supersede AS/NZS 3500.3.2—1998, *National Plumbing and Drainage, Part 3.2: Stormwater drainage—Acceptable solution*.

This Standard incorporates Amendment No. 1 (July 2006) and Amendment No. 2 (March 2010). The changes required by the Amendment are indicated in the text by a marginal bar and amendment number against the clause, note, table, figure or part thereof affected.

The objective of this Standard is to provide installers with solutions to comply with—

- (a) the Plumbing Code of Australia (PCA);
- (b) the Building Code of Australia (BCA); and
- (c) the Building Code of New Zealand for stormwater drainage.

This Standard is part of a series for plumbing and drainage, as follows:

AS/NZS

- 3500 Plumbing and drainage
- 3500.0 Part 0: Glossary of terms
- 3500.1 Part 1: Water services.
- 3500.2 Part 2: Sanitary plumbing and drainage systems
- 3500.3 Part 3: Stormwater drainage systems (this Standard)
- 3500.4 Part 4: Heated water services.
- 3500.5 Part 5: Domestic installations

This revision includes the following changes:

- (i) Changes in the context to enable this Standard to be referenced in the above listed Codes.
- (ii) The inclusion of revised clauses to bring them into line with the provisions of the Plumbing Code of Australia.
- (ii) Revision of the materials and products used in stormwater drainage systems.
- (iii) Incorporation of Amendment 1 and RUL PL.13—2002.
- (iv) Revised examples in Appendix H.

Other changes incorporate amendments and additions arising from industry recommendations which include—

- (a) changes in limitations in FRC pipes and epoxy resins; and
- (b) clarification of examples for design of eaves gutters of slope less than 1:500.

This Standard does not cover the criteria for soakers and siphonic systems. Sufficient data was not available in these areas at the time of publication. These areas will be included in a future edition of this Standard, subject to additional research and investigation being carried out.

The terms ‘normative’ and ‘informative’ have been used in this Standard to define the application of the appendix to which they apply. A ‘normative’ appendix is an integral part of a Standard, whereas an ‘informative’ appendix is only for information and guidance.

Statements expressed in mandatory terms in notes to figures and tables are deemed to be requirements of this Standard.

PROVISION FOR REVISION

This Standard necessarily deals with existing conditions, but is not intended to discourage innovation or to exclude materials, equipment and methods, which may be developed in future. Revisions will be made from time to time in view of such developments and amendments to this edition will be made only when absolutely necessary.

CONTENTS

| | <i>Page</i> |
|--|-------------|
| SECTION 1 SCOPE AND GENERAL | |
| 1.1 SCOPE AND APPLICATION..... | 7 |
| 1.2 REFERENCED DOCUMENTS | 7 |
| 1.3 DEFINITIONS | 7 |
| 1.4 NOTATION | 9 |
| 1.5 IDENTIFICATION | 12 |
| 1.6 PROTECTION OF WORKS | 12 |
| 1.7 DISCHARGE POINT CRITERIA | 13 |
| SECTION 2 MATERIALS AND PRODUCTS | |
| 2.1 SCOPE OF SECTION | 14 |
| 2.2 AUTHORIZATION..... | 14 |
| 2.3 SELECTION AND USE..... | 14 |
| 2.4 ROOF DRAINAGE SYSTEM..... | 14 |
| 2.5 STORMWATER DRAINS (NON-PRESSURE)..... | 15 |
| 2.6 RISING MAINS (PRESSURE) | 16 |
| 2.7 SUBSOIL DRAINS | 16 |
| 2.8 JOINTS..... | 16 |
| 2.9 VALVES | 18 |
| 2.10 CONCRETE AND MORTAR | 18 |
| 2.11 EMBEDMENT MATERIAL | 19 |
| 2.12 TRENCH FILL..... | 19 |
| 2.13 MISCELLANEOUS | 19 |
| 2.14 FILTERS FOR SUBSOIL DRAINS | 20 |
| SECTION 3 ROOF DRAINAGE SYSTEMS—DESIGN | |
| 3.1 SCOPE OF SECTION | 21 |
| 3.2 GENERAL METHOD..... | 21 |
| 3.3 METEOROLOGICAL CRITERIA | 21 |
| 3.4 CATCHMENT AREA..... | 22 |
| 3.5 EAVES GUTTER SYSTEMS | 27 |
| 3.6 VALLEY GUTTERS..... | 32 |
| 3.7 BOX GUTTER SYSTEMS..... | 33 |
| 3.8 SOAKERS..... | 35 |
| SECTION 4 ROOF DRAINAGE SYSTEMS—INSTALLATIONS | |
| 4.1 SCOPE OF SECTION | 42 |
| 4.2 TRANSPORT, HANDLING AND STORAGE | 42 |
| 4.3 THERMAL VARIATION | 42 |
| 4.4 CORROSION | 43 |
| 4.5 INSTALLATION AND TESTING..... | 44 |
| 4.6 INSPECTION AND CLEANING..... | 47 |
| 4.7 ALTERATIONS AND DISCONNECTION | 47 |
| 4.8 EAVES GUTTERS..... | 47 |
| 4.9 BOX GUTTERS..... | 47 |
| 4.10 VALLEY GUTTERS..... | 48 |
| 4.11 DOWNPIPES | 48 |
| 4.12 OVERFLOW DEVICES OR MEASURES..... | 49 |
| 4.13 JOINTS FOR METAL COMPONENTS | 49 |

| | | |
|--|---|-----|
| 4.14 | JOINTS FOR PVC COMPONENTS | 50 |
| 4.15 | JOINTS FOR OTHER COMPONENTS | 50 |
| 4.16 | SUPPORT SYSTEMS | 52 |
| SECTION 5 SURFACE DRAINAGE SYSTEMS—DESIGN | | |
| 5.1 | SCOPE OF SECTION | 54 |
| 5.2 | DESIGN METHODS | 54 |
| 5.3 | LAYOUT | 54 |
| 5.4 | GENERAL METHOD | 56 |
| 5.5 | NOMINAL METHOD | 68 |
| SECTION 6 SUBSOIL DRAINAGE SYSTEMS—DESIGN | | |
| SECTION 7 SURFACE AND SUBSOIL DRAINAGE SYSTEMS—INSTALLATION | | |
| 7.1 | SCOPE OF SECTION | 70 |
| 7.2 | GENERAL REQUIREMENTS | 70 |
| 7.3 | SITE STORMWATER DRAINS | 75 |
| 7.4 | SUBSOIL DRAINS | 79 |
| SECTION 8 SURFACE AND SUBSOIL DRAINAGE SYSTEMS—ANCILLARIES | | |
| 8.1 | SCOPE OF SECTION | 81 |
| 8.2 | PAVED SURFACES | 81 |
| 8.3 | POINT(S) OF CONNECTION | 81 |
| 8.4 | REFLUX VALVES | 81 |
| 8.5 | INSPECTION OPENINGS | 82 |
| 8.6 | STORMWATER PITS, INLET PITS AND ARRESTERS | 82 |
| 8.7 | SURCHARGE OUTLETS | 88 |
| 8.8 | JUNCTIONS | 88 |
| 8.9 | JUMP-UPS | 89 |
| 8.10 | ANCHOR BLOCKS | 90 |
| 8.11 | ON-SITE STORMWATER DETENTION (OSD) SYSTEMS | 91 |
| SECTION 9 PUMPED SYSTEMS | | |
| 9.1 | SCOPE OF SECTION | 94 |
| 9.2 | GENERAL | 94 |
| 9.3 | WET WELLS | 94 |
| 9.4 | PUMPS | 95 |
| 9.5 | RISING MAINS | 95 |
| 9.6 | ELECTRICAL CONNECTION | 95 |
| SECTION 10 SITE TESTING | | |
| 10.1 | SCOPE OF SECTION | 96 |
| 10.2 | DOWNPIPES, SITE STORMWATER DRAINS AND DRAINS WITHIN OR UNDER BUILDINGS | 96 |
| 10.3 | TEST CRITERIA | 96 |
| 10.4 | PROCEDURE | 97 |
| APPENDICES | | |
| A | REFERENCED AND RELATED DOCUMENTS | 98 |
| B | SITE-MIXED CONCRETE FOR MINOR WORKS | 102 |
| C | STORMWATER DRAINAGE INSTALLATION PLANS | 103 |
| D | GUIDELINES FOR DETERMINING RAINFALL INTENSITIES | 105 |
| E | RAINFALL INTENSITIES FOR AUSTRALIA—5 MIN DURATION | 106 |

| | <i>Page</i> |
|---|-------------|
| F RAINFALL INTENSITIES FOR NEW ZEALAND — 10 MIN DURATION | 124 |
| G EXAMPLES OF OVERFLOW MEASURES FOR EAVES GUTTERS..... | 129 |
| H GENERAL METHOD FOR DESIGN OF EAVES GUTTER SYSTEMS — EXAMPLE | 133 |
| I BOX GUTTER SYSTEMS — GENERAL METHOD, DESIGN GRAPHS AND ILLUSTRATIONS | 143 |
| J BOX GUTTER SYSTEMS — GENERAL METHOD — EXAMPLES | 152 |
| K SURFACE DRAINAGE SYSTEMS — NOMINAL AND GENERAL METHODS — EXAMPLES | 162 |
| L EXAMPLE CALCULATION — PUMPED SYSTEM..... | 173 |
| M SUBSOIL DRAINAGE SYSTEMS — DESIGN..... | 175 |

STANDARDS AUSTRALIA/STANDARDS NEW ZEALAND

Australian/New Zealand Standard Plumbing and drainage

Part 3: Stormwater drainage

SECTION 1 SCOPE AND GENERAL

1.1 SCOPE AND APPLICATION

1.1.1 Scope

This Standard covers materials, design, installation and testing of roof drainage systems, surface drainage systems and subsoil drainage systems to a point of connection.

1.1.2 Application

1.1.2.1 *Building Code of Australia*

This Standard may be used as a means of demonstrating compliance with the requirements of Part F1 of Volume One and Parts 3.1.2 and 3.5.2 of the Housing Provisions of the Building Code of Australia.

This Standard will be referenced in the Building Code of Australia by way of BCA Amendment 14 to be published by 1 May 2004.

1.1.2.2 *Plumbing Code of Australia*

This Standard will be referenced in the Plumbing Code of Australia.

1.2 REFERENCED DOCUMENTS

The documents referred to in this Standard are listed in Appendix A.

NOTE: A list of related documents is given in Paragraph A2, Appendix A

1.3 DEFINITIONS

1.3.1 General

For the purpose of this Standard, the definitions in AS/NZS 3500.0 and those below apply. The definitions listed below specifically apply to this Standard.

1.3.2 Average recurrence interval (ARI)

The average or expected interval between events of a given rainfall intensity being exceeded.

NOTE: The ARI is an average value based on statistical analysis. The actual time between exceedances will vary.

1.3.3 Box gutter

Graded channel, generally of rectangular shape, for the conveyance of rainwater, located within the building. Includes a gutter adjacent to a wall or parapet (see Figures 15, 17).

1.3.4 External stormwater drainage network

A system that collects and conveys stormwater from individual properties.

NOTE: The network includes easement or inter-allotment drains, and street and trunk drainage systems.

1.3.5 Inert catchment

A rainwater collection area whose dominant material has little or no effect on the chemical composition of rainwater draining from it. Such materials include acrylic, fibreglass, aluminium/zinc alloy-coated steel, glass, glazed tiles, unplasticized polyvinyl chloride and pre-painted metal.

1.3.6 On-site stormwater detention (OSD)

A device for the temporary storage of stormwater, above or below ground, to reduce the peak flow to the stormwater drainage network.

1.3.7 Overflow device

A device to safely divert flow in the event of a blockage, for use with the roof drainage system of a box gutter.

1.3.8 Overflow measure

Measure to divert water from flowing back into a building from a blockage anywhere along or at the outlet of an eaves gutter (see Figure G1).

1.3.9 Permanent ponding

Ponding along the sole of eaves and box gutters when free water is evident for more than three days after the cessation of flow.

1.3.10 Point of connection

The point provided for the connection of a site stormwater drain to the stormwater drainage network.

NOTE: Where a property is more than 90 m from an external stormwater drainage network, the network utility operator may permit an alternative point of connection.

1.3.11 Rainhead

A collector of rainwater, generally of rectangular shape, at the end of a box gutter and external to a building, connected to an external downpipe (see Figure I2). It has a similar function to a sump (see Clause 1.3.19).

1.3.12 Sag pit

An inlet pit located in a depression where stormwater ponds over the inlet due to restricted entry.

1.3.13 Spreader

A device fitted to the foot of a downpipe to evenly distribute rainwater onto a roof at a lower level. It is generally used where it is undesirable for practical or aesthetic reasons to connect the high-level roof downpipe directly to the storm water drainage system.

1.3.14 Stormwater

Naturally occurring water that results from rainfall on or around the site, or water flowing onto the site.

1.3.15 Stormwater drainage system

The roof drainage system, surface drainage system and subsoil drainage system on a property, which is used for the collection and conveyance of stormwater.

1.3.16 Subsoil drain

A buried conduit for the collection and conveyance of subsurface and ground water.

1.3.17 Sump

A collector of rainwater, generally of rectangular shape, in the sole of a box gutter and connected to a downpipe within the building perimeter. Its function is to increase the head of water at the entry to the downpipe and thus increase the capacity of the downpipe (see Figures 15 and 17).

1.3.18 Sump/high capacity overflow device

An overflow device associated with an internal box gutter and sump (see Figure 3.7(c)).

1.3.19 Sump/side overflow device

An overflow device associated with an internal box gutter alongside a parapet wall (see Figure 2.7(b)).

1.3.20 Valley gutters

Inclined channels placed at the intersecting sloping surfaces of the adjacent roof for the conveyance of rainwater.

1.3.21 Plastics abbreviations

The following plastics abbreviations are used in this Standard.

| | |
|-------|----------------------------------|
| PVC-U | Unplasticized polyvinyl chloride |
| PVC-M | Modified polyvinyl chloride |
| PVC-O | Oriented polyvinyl chloride |
| PE | Polyethylene |
| PP | Polypropylene |
| PE-X | Cross-linked polyethylene |
| ABS | Acrylonitrile styrene |
| PB | Polybutylene |

1.4 NOTATION

1.4.1 Quantity symbols

Quantity symbols used in this Standard are listed below.





| Quantity Symbol | Definition | Unit |
|--------------------|--|--------|
| A | = cross-sectional area of flow in an open channel | m^2 |
| A_c | = catchment area of a roof and vertical surface (wall or parapet) | m^2 |
| A_{cdp} | = for a selected eaves gutter, the maximum catchment area of roof per vertical downpipe (see Appendix H) | m^2 |
| A_{s-c} | = eaves gutter sub-catchment area for a particular downpipe and high point layout | m^2 |
| A_e | = effective cross-sectional area of a gutter | mm^2 |
| A_h | = plan area of a roof including the gutter or parapet which is part of the catchment | m^2 |
| A_{hdp} | = for a selected eaves gutter, the maximum plan area of roof per downpipe | m^2 |

| Quantity Symbol | Definition | Unit |
|--------------------|---|-------|
| A_{hs-c} | = plan area of sub-catchment roof including the gutter or parapet which is part of the catchment | m^2 |
| A_i | = total unroofed impervious (paved) catchment area | m^2 |
| A_p | = total unroofed pervious catchment area | m^2 |
| A_r | = total roofed catchment area | m^2 |
| A_v | = maximum elevation area of a sloping roof, vertical surface, wall or parapet | m^2 |
| b_f | = blockage factor, for inlet-to-inlet pit | — |
| b_n | = nominal breadth of cross-section of a rectangular or square downpipe | mm |
| ΣCA | = equivalent impervious area of all upstream areas on the property | m^2 |
| C_i | = run-off coefficient, for an unroofed impervious (paved) area | — |
| C_p | = run-off coefficient for an unroofed pervious area | — |
| C_r | = run-off coefficient for a roofed area | — |
| D_e | = effective equivalent diameter of a rectangular downpipe, $2 \times \sqrt{\frac{b_n \times w_n}{\pi}}$, or square downpipe $2\sqrt{\frac{b_n^2}{\pi}}$ | mm |
| D_i | = internal diameter of a circular downpipe | mm |
| d_{bg} | = minimum depth of a box gutter that discharges to a sump/high-capacity overflow device (includes h_f) (see Figure 3.10 and Figure 17) | mm |
| d_p | = depth of ponding over an inlet to an inlet pit | m |
| d_{oc} | = minimum depth of an overflow channel | mm |
| F | = catchment area of a roof-slope factor (see Table 3.2) | — |
| h_a | = minimum depth of a box gutter that discharges to a rainhead (includes h_f) (see Figure 11) | mm |
| h_e | = effective depth | mm |
| h_f | = freeboard | mm |
| h_r | = total depth of a rainhead | mm |
| h_s | = depth of a sump | mm |
| h_t | = minimum height of the top of the box gutter above the crest of the overflow weir or channel as shown on Figures 15 and 17 | mm |
| ${}^Y I_t$ | = rainfall intensity for a duration of t and an ARI of Y | mm/h |
| k | = Colebrook-White roughness coefficient | mm |

| Quantity Symbol | Definition | Unit |
|--------------------|---|-------|
| l_{oc} | = for a sump/side overflow device, the minimum horizontal distance between the sides of an overflow channel and those of the sump (see Figure I5) | mm |
| | = for sump/high-capacity overflow device, the height of the overflow weir (crest) above the sole of the gutter (see Figure I7) | mm |
| l_r | = length of a rainhead | mm |
| m | = multiplier for rainfall run-off coefficients (see equation 3.4.6) | — |
| n | = Manning roughness coefficient for an open channel | — |
| P | = wetted perimeter of an open channel | m |
| R | = hydraulic radius, $R = A_p$ | m |
| S | = gradient, for an open channel | — |
| Q | = design flow of stormwater | |
| Q_c | = discharge capacity for an open channel | L/s |
| Q_i | = capacity of an inlet for a sag pit | L/s |
| T | = time | min |
| w_{bg} | = width of a box gutter | mm |
| w_c | = effective width | mm |
| w_n | = nominal width of cross-section of a rectangular or square downpipe | mm |
| w_{oc} | = width of an overflow channel | mm |
| Y | = average recurrence interval (ARI) | years |

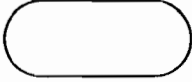
1.4.2 Flow chart symbols

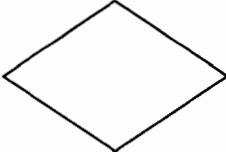
Flow chart symbols and conventions used in this Standard are listed below.

| Flow chart symbol | Use |
|---|---|
|  | = terminator, represents an entry from or an exit to an outside environment, e.g., start or finish of a flow chart |
|  | = data input |
|  | = process, execute defined operation or group of operations resulting in a change in value |
|  | = decision or switching, a single entry with more than one exit only one of which will be activated following the evaluation of the condition |
|  | = connector, represents an exit to or an entry either from another part of the same flow chart, or from another flow chart and corresponding symbols shall contain the same unique identification |

1.4.3 Gradients

In this Standard, gradients are expressed in the form of a numerical ratio Y:X, where Y is the vertical dimension and X is the horizontal dimension of a right-angle triangle.

1.5 IDENTIFICATION

Where, other than in single dwellings, pipework that cannot be immediately and clearly identified is installed in ducts, accessible ceilings or exposed in basements, plant rooms, or similar, it shall be clearly identified in accordance with AS 1345 or NZS 5807.

1.6 PROTECTION OF WORKS

1.6.1 Roof drainage systems

NOTE: Roof drainage systems that could be damaged by acid should not be installed adjacent to or below brickwork prior to its having been washed down with acid or similar.

1.6.2 Surface drainage and subsoil drainage systems

Whenever the ground is opened for any purpose, within or in proximity to a property, all necessary measures shall be taken to protect the surface drainage and subsoil drainage systems from damage during the course of such work, and to prevent the entry of—

- (a) soil, sand, or rock;
- (b) sewage, including the contents of any septic tank, or trade waste; or
- (c) any other substance that would damage or impede the operation of the stormwater drainage network.

1.7 DISCHARGE POINT CRITERIA

1.7.1 Position and manner of discharge

NOTES:

- 1 The authority having jurisdiction may determine the position and manner of discharge of the stormwater drainage system.
- 2 Point(s) of connection to the stormwater system for a property—
 - (a) may be located—
 - (i) within the property; or
 - (ii) external to the property, i.e., the surface water drain extends beyond the property; and
 - (b) should transfer stormwater by gravity or pumping, or both, from the site stormwater drain to the stormwater drainage network.
- 3 The forms of points of connection include—
 - (a) a direct connection to a street kerb and gutter (see Clause 8.6.1.2(c)); or
 - (b) connection to an element of the external stormwater drainage network, e.g. a conduit or open channel located in a street or easement.
- 4 Where the stormwater from a property discharges through a mountable kerb to the gutter of a roadway, the design and materials used to create the outfall should have sufficient strength and durability to withstand the loads to which it will be subjected throughout the service life of the kerb. The structural adequacy of the preformed outlets should be verified by load testing or structural analysis. Any preformed outlet should be approved by the network utility operator before being installed. Where practicable, for new kerb construction, outlets should be installed in conjunction with the forming of the kerb.
- 5 Where the network utility operator has determined an operating water level, within its own external stormwater drainage network for a gravitational point of connection, care should be taken to ensure that any floor or basement level is above this level, and that the site stormwater system has appropriate outlets to operate as surcharge outlets (see also Clause 5.4.12).
- 6 Where the recommendations of Note 4 cannot be applied, consideration should be given to the installation of—
 - (a) a reflux valve (see Clause 8.4); or
 - (b) a pumped system (see Section 9).

1.7.2 Stormwater drainage plans

NOTE: Typical information that may be required for a stormwater plan is given in Appendix C.

SECTION 2 MATERIALS AND PRODUCTS

2.1 SCOPE OF SECTION

This Section specifies requirements for materials and products for use in a stormwater drainage system.

2.2 AUTHORIZATION

NOTE: In states and territories where stormwater installations are required to comply with the Plumbing Code of Australia, materials and products used in stormwater and drainage systems may require authorization and shall be manufactured to the relevant Australian Standard (see PCA).

2.3 SELECTION AND USE

Materials and products used in a stormwater drainage system shall be selected to ensure satisfactory service for the life of the installation.

Factors to be taken into account in the selection shall include but not be limited to—

- (a) the nature of the intended use of the building;
- (b) the environment;
NOTE: See AS/NZS 2312 or the relevant product Standard.
- (c) the nature of the ground, quality of subsoil water and the possibility of chemical attack there from;
- (d) the physical (e.g., abrasion) and chemical (e.g., corrosion) characteristics of the materials and products; and
- (e) components of installations manufactured from more than one material, with either contact between or drainage to them (see Note 3).

NOTES:

- 1 The manufacturer's recommended installation and maintenance procedures for the materials and products selected should also be considered.
- 2 Where materials are used for collection of drinking water, the use of materials complying to AS/NZS 4020 should be considered.
- 3 For material compliance see Clause 4.4.1 or Clause 4.4.2.

2.4 ROOF DRAINAGE SYSTEM

2.4.1 Roof drainage system components

Roof drainage system components made from aluminium alloys, aluminium/zinc alloy-coated steel, copper, copper alloys, zinc-coated steel, stainless steel and zinc shall comply with AS/NZS 2179.1.

PVC components shall comply with AS/NZS 2179.2(Int).

2.4.2 Downpipes

Materials and products, other than those specified in Clause 2.4.1, used for downpipes shall comply with the following:

- (a) AS/NZS 1866 for aluminium alloy pipes, which shall be in straight lengths, i.e., not bent.
- (b) AS 1631 for cast iron pipes and fittings.

- (c) AS 1432 and AS 3517, respectively, for copper pipes and fittings which shall satisfy the following additional criteria:
 - (i) When Type B pipe is field bent, the offset angle shall be not greater than 10°.
 - (ii) Type D pipe shall be in straight lengths, i.e. not bent.
 - (iii) Fabricated bends and junctions at the base of downpipes less than 9 m high shall be, as a minimum, fittings suitable for Type D applications.
- (d) Copper alloy pipes and fittings as specified in AS 3795 and AS 3517, respectively, with the following limitations on use:
 - (i) Type D shall be in straight lengths, i.e., not bent.
 - (ii) Only junctions shall be field fabricated.
 - (iii) Only cast or hot-pressed bends and junctions shall be used at the base of downpipes with heights equal to or greater than 9 m.
- (e) Ductile iron pipes and fittings as specified in AS/NZS 2280.
- (f) Fibre-reinforced concrete (FRC) pipes and fittings as specified in AS 4139, which shall be autoclaved.
NOTE: Where FRC pipes are used in areas aggressive to concrete pipes the manufacturers recommendations should be sought.
- (g) Galvanized steel pipes and malleable cast iron fittings as specified in AS 1074 and AS 3673, respectively, with the following limitations on use:
 - (i) Pipes shall be in straight lengths, i.e., not bent.
 - (ii) Pipes and fittings shall be installed in accessible locations.
- (h) Glass-filament-reinforced thermosetting plastics (GRP) pipes as specified in AS 3571, and where exposed to direct sunlight, have adequate resistance to UV.
- (i) Polyvinyl chloride (PVC) pipes and fittings as specified in AS/NZS 1254, AS/NZS 1260, AS 1273, AS/NZS 1477 or AS/NZS 2179.2(Int).
- (j) Polyethylene (PE) pipes and fittings complying with AS/NZS 4129, AS/NZS 4130 or AS/NZS 4401(Int), and unless coloured black, pipes and fittings shall not be exposed to direct sunlight without protection in accordance with AS 2033.

2.4.3 Accessories and fasteners

Accessories and fasteners manufactured from aluminium alloys, aluminium/zinc alloy-coated steel, copper, copper alloys, zinc-coated steel, stainless steel and zinc shall comply with AS/NZS 2179.1.

NOTES:

- 1 Metal accessories and fasteners specified in AS/NZS 2179.1 may be suitable for gutters and downpipes manufactured from PVC.
- 2 Accessories manufactured from PVC should comply with AS/NZS 2179.2(Int).

2.5 STORMWATER DRAINS (NON-PRESSURE)

The following applies to products used for non-pressure stormwater drains:

- (a) Aluminized or galvanized steel shall be as specified in AS 1761.
- (b) Cast iron, copper, copper alloys, ductile iron pipes and fittings shall comply with Items (b) to (e), respectively, of Clause 2.4.2.
- (c) FRC pipes and fittings shall be as specified in AS 4139 and shall have the following limitations on use:

- (i) Site fittings shall be concrete encased where the resin used to manufacture fittings has not been designed for the required stormwater drainage in-service application.

NOTE: Where FRC pipes are used in areas aggressive to concrete pipes the manufacturer's recommendations should be sought.

- (ii) Pipes and fittings shall be autoclaved.
- (d) Galvanized steel pipes and malleable cast iron shall comply with Clause 2.4.2 (g).
- (e) GRP pipes and fittings, minimum Class SN 2500, shall be as specified in AS 3571 and shall, where exposed to direct sunlight, have adequate resistance to UV radiation.
- (f) PE pipes shall comply with Clause 2.4.2(j).
- (g) Precast concrete pipes (steel reinforced) as specified in AS 4058 or NZS 3107 and, where located under buildings, they shall have no lifting holes.
NOTE: Where concrete pipes are used in areas aggressive to concrete pipes the manufacturer's recommendations should be sought.
- (h) Circular PVC pipes and fittings shall comply with Clause 2.4.2(i).
- (i) Stainless steel shall be as specified in Section 2 of AS/NZS 3500.1.
- (j) Vitrified clay or ceramic pipes and fittings shall be as specified in BS EN 295-1.

2.6 RISING MAINS (PRESSURE)

Rising mains shall be constructed from pressure pipes and fittings as specified in Section 2 of AS/NZS 3500.1.

2.7 SUBSOIL DRAINS

Plastics pipes used in subsoil drains shall comply with AS 2439.1. Class 100 of such pipes shall be limited to use in single dwellings.

2.8 JOINTS

2.8.1 Resin adhesives

2.8.1.1 General

Resin adhesives shall have positive adhesion to, and compatibility with, the materials being jointed.

2.8.1.2 Sealants

Sealants, including caulking compounds and tapes, shall—

- (a) be neutral cure;
- (b) where exposed above ground, be resistant to ultraviolet radiation;
- (c) have the appropriate range of service temperatures for the location;
- (d) have positive adhesion to and compatibility with the materials being jointed; and
- (e) where applicable, retain flexibility throughout the service life.

2.8.1.3 Silver brazing alloy

Silver brazing alloys used for jointing copper and copper alloy pipes and fittings shall comply with AS 1167.1 and shall have a silver content of not less than 1.8%.

2.8.1.4 Soft solder

Soft solder shall comply with AS 1834.1 and—

- (a) for roof drainage system components, used for the conveyance of drinking water, have a lead content of not more than 0.1%;
- (b) for zinc-coated steel, copper, copper alloy and stainless steel, be 50/50 solder to Grade 50 Sn; and
- (c) for zinc, have an antimony content of less than 0.5%.

2.8.1.5 Solvent cement and priming fluid

Solvent cement and priming fluid used for jointing PVC pipes and fittings shall comply with AS/NZS 3879.

2.8.2 Types**2.8.2.1 Bolted gland (BG)**

Bolted gland joints shall comply with AS 1631 for cast grey and ductile iron materials with elastomeric seals appropriate to the material and dimensions of the pipes or fittings being jointed.

2.8.2.2 Cement mortar (CM)

Cement mortar joints shall comply with Clause 2.10.4.

2.8.2.3 Elastomeric seals (ES)

Elastomeric seals shall comply with the relevant product Standard.

2.8.2.4 Epoxy resin (ER)

Epoxy resin shall be appropriate to the materials being jointed and shall be mixed and applied in accordance with the manufacturer's instructions. Epoxy resin shall be used only where the joint is designed for its use.

Fittings fabricated on site using an epoxy should be concrete encased when installed below a permanent water table unless the epoxy has been approved for use in such applications.

2.8.2.5 Fusion welded (FW)

Fusion welded joints shall be appropriate to the materials being jointed and carried out with suitable consumables and techniques in accordance with the manufacturer's recommendations by a suitably qualified competent person.

2.8.2.6 Mechanical coupling (MC)

Mechanical couplings shall comply with AS 1761.

2.8.2.7 Metal-banded flexible coupling (FC)

Metal-banded flexible couplings shall comply with AS/NZS 4327.

2.8.2.8 Silver brazed (SB)

Silver-brazed joints shall be made from silver brazing alloy complying with Clause 2.8.1.3. Joints shall be made by either—

- (a) using authorized fittings; or
- (b) fabricating junctions from the pipes.

2.8.2.9 Soft soldered (SS)

Soft soldered joints shall be made from solder complying with Clause 2.8.1.4 and shall be used only for jointing zinc-coated steel, copper, copper alloy and stainless steel rainwater goods.

2.8.2.10 Solvent cement (SC)

Solvent cement joints for PVC pipes and fittings shall be made in accordance with AS 2032.

2.8.2.11 Threaded (TH)

Threaded joints shall comply with the relevant standards for the materials to be jointed and be sealed with an appropriate jointing medium.

2.9 VALVES

2.9.1 Gate and globe

Copper alloy gate and globe valves shall comply with AS 1628.

2.9.2 Flap

Flap valves shall comply with Clause 2.3.

2.9.3 Non-return

Cast iron and copper alloy non-return valves shall comply with AS 3578 and AS 1628, respectively.

2.9.4 Reflux

Reflux valves shall comply with Clause 2.3.

2.9.5 Sluice

Gate valves shall comply with AS 2638.1 or AS 2638.2.

2.9.6 Wedge gate

Cast iron wedge gate valves shall comply with AS 3579.

2.10 CONCRETE AND MORTAR

2.10.1 Concrete

Ready-mixed concrete shall comply with AS 1379 and shall have a minimum characteristic compressive strength of 15 MPa, as defined in AS 3600.

For minor works, site-mixed concrete shall consist of cement, fine aggregate, and coarse aggregate all measured by volume, and sufficient water added to make the mix workable. It shall have a minimum strength compromise of 15 MPa.

NOTE: See Appendix B for typical mixes for minor works.

Packaged concrete mixes shall comply with AS 3648.

2.10.2 Cement mortar

Cement mortar shall consist of one part cement and three parts fine aggregate measured by volume, thoroughly mixed with the minimum amount of water necessary to render the mix workable.

Cement mortar, which has been mixed and left standing for more than 1 h, shall not be used.

2.10.3 Chemical admixtures

Chemical admixtures used in concrete shall comply with AS 1478.1.

2.10.4 Water for concrete and mortar

Water used for mixing concrete and cement mortar shall be free from matter that is harmful to the mixture, the reinforcement or any other items embedded within the concrete or mortar.

2.10.5 Steel reinforcement

Steel reinforcing materials used in concrete structures shall comply with AS/NZS 4671.

2.11 EMBEDMENT MATERIAL

2.11.1 Site stormwater drains

Embedment material for below ground site stormwater drains shall be as specified in Clause 7.4.2.1.

2.11.2 Subsoil drains

Embedment for subsoil drains shall be as specified in Clause 7.4.2.1.

2.12 TRENCH FILL

Trench fill for site stormwater drains and subsoil drains shall be as specified in Clause 7.2.12.

2.13 MISCELLANEOUS

2.13.1 Clay building bricks

Clay building bricks shall comply with AS/NZS 4455.

2.13.2 Concrete masonry units

Concrete masonry units (concrete bricks or concrete blocks) shall comply with AS/NZS 4455.

2.13.3 Cover and sump grates

Metal access cover and sump grates and frames for stormwater and inlet pits and arresters shall comply with AS 3996. Structurally adequate support shall be provided for access covers, sump grates and frames.

2.13.4 External protective coating

The external protective coating of metal pipes and fittings shall—

- (a) be impervious to the passage of moisture;
- (b) be resistant to—
 - (i) the external corrosive environment; and
 - (ii) damage by the embedment material; and
- (c) not contain material that could cause corrosion.

2.13.5 Fibreglass-reinforced plastic tanks

Water collection tanks for re-use water shall comply with AS/NZS 3500.1

2.13.6 Geotextiles

Geotextiles shall be marked in accordance with AS 3705 and shall comply with Clause 2.3.

2.13.7 Polyethylene sleeving

Polyethylene sleeving for corrosion protection shall comply with AS 3680.

2.13.8 Precast or prefabricated pits and arresters

2.13.8.1 Concrete

Precast concrete units for pits shall comply with the dimensions given in Table 8.2, and shall—

- (a) in New Zealand, comply with all relevant requirements of NZS 3107;

- (b) comply with the relevant criteria of AS 4198; or
 - (i) support for a minimum of 30 s, without structural failure or significant cracking, the appropriate pit lid design loads in accordance with AS 3996 (where a precast unit has knock-out panels, this requirement shall apply with the knock-out panels removed); and
 - (ii) be classified and marked in accordance with the pit lid classification of AS 3996 for which they are designed.

2.13.8.2 *Corrugated metal*

Prefabricated corrugated metal pits and arresters shall comply with AS 1761 and shall support, without structural failure, the appropriate pit lid design loads in accordance with AS 3996.

2.13.8.3 *Other materials*

Precast or prefabricated pits and arresters of materials, other than specified in Clauses 2.13.8.1 and 2.13.8.2, shall satisfy the performance requirements of the Plumbing Code of Australia and shall support, without structural failure, the appropriate pit lid design loads in accordance with AS 3996.

2.13.9 **Timber**

Timber exposed to the weather shall be of durability Class 2 complying with AS/NZS 2878 or NZS 3631 or shall be treated in accordance with AS 1604.1 or NZS 3640.

2.14 **FILTERS FOR SUBSOIL DRAINS**

2.14.1 **Filter material**

Filter materials consisting of natural clean washed sands and gravels and screened crushed rock shall be—

- (a) well graded, with a mix of different sizes of sand particles and an adequate permeability with—
 - (i) natural sand, less than 5% passing a 75 μm sieve; and
 - (ii) screened crushed rock, sizes 3 mm to 20 mm;
- (b) sufficiently coarse not to wash into the subsoil drain, or through pores in a geotextile cover to such drain; and
- (c) chemically stable and inert to possible actions of soil and ground water.

NOTE: Design requirements set on the basis of the grading curves of the native soils and filter material are too complex for routine use by builders, and require specific tests.

2.14.2 **Geotextile filters**

The permeability of geotextiles used in subsoil drains shall be greater than that of the native soil.

NOTES:

- 1 A desirable permeability for geotextiles is 10 times that of the native soil.
- 2 There is a tendency for geotextiles to clog at some locations, particularly where iron salts are present, e.g., scoria. Oxidization and biologically related actions can cause plate-like deposits of ferruginous particles on filter surfaces, rapidly clogging them. In such areas, carefully selected granular filters should be used instead of geotextiles. Advice from a professional engineer with geotechnical expertise should be sought in such situations.

SECTION 3 ROOF DRAINAGE SYSTEMS — DESIGN

3.1 SCOPE OF SECTION

This Section specifies methods for the design of and procedures for roof drainage systems.

3.2 GENERAL METHOD

The general method assumes regular inspection and cleaning (see Clause 4.6) and is applicable to—

- (a) eaves gutters and associated vertical downpipes with appropriate overflow measures (see Clause 3.5);
- (b) valley gutters (see Clause 3.6);
- (c) box gutters and associated vertical downpipes with appropriate overflow devices (see Clause 3.7); and
- (d) soakers (see Clause 3.8).

NOTES:

- 1 The general method does not include allowance for any of the following:
 - (a) Localized variation in rainfall intensities due to wind or adjacent buildings.
 - (b) Blockages of roof drainage systems, e.g., by snow, hail and debris.
 - (c) Reduced hydraulic capacity caused by—
 - (i) reduced gutter gradient due to ground movement; or
 - (ii) turbulence due to wind.
- 2 An example that illustrates the application of the general method is given in Appendix H.

3.3 METEOROLOGICAL CRITERIA

3.3.1 General

Roof drainage systems are designed in respect to potential monetary loss, property damage (including contents of buildings) and injury to persons due to overtopping.

NOTES:

- 1 A frequent cause of such overtopping is inadequate inspection and cleaning (see Clause 4.6) and not the intensity of rainfall.
- 2 Although hail can restrict or block roof drainage systems the present lack of performance data prevents the inclusion of requirements for hail barriers, as published in REBUILD (see Ref. 8, Paragraph A2, Appendix A).

3.3.2 Snowfall effects

In regions subject to snowfalls, for roof drainage systems, there shall be no effect on size but precautions are necessary to minimize the entry of rainwater or meltwater, or both, into buildings.

NOTES:

- 1 Roof drainage support systems should be designed to include an appropriate allowance for snow load (see AS/NZS 1170.3).
- 2 Sometimes eaves gutters are not used in alpine regions because the stormwater from roofs is collected at ground level, generally in site stormwater channels.

3.3.3 Wind effects

An allowance for the effects of wind on rainfall is required for other than flat or permanently protected sloping surfaces (see Clause 3.4). A gradient of 2:1 shall be adopted.

NOTE: As studies in Australia are insufficient to determine the maximum gradient of descent of wind-driven rain at design intensity United Kingdom practice has been adopted (see BS EN 12056-3)

3.3.4 ARI

The ARI shall be as given in Table 3.1.

TABLE 3.1
AVERAGE RECURRENCE INTERVAL (ARI)

| Effect of overtopping | ARI, years | |
|---|------------|-------------|
| | Australia | New Zealand |
| Where significant inconvenience or injury to people or damage to property (including contents of buildings) is— | | |
| (a) an unlikely occurrence, e.g., caves gutters, external; or | ≥20 | ≥10 |
| (b) a likely occurrence, e.g., box gutters | ≥100 | ≥50 |

NOTE: For Australia Table 3.1 should be used in conjunction with the BCA, which has requirements to prevent rain and stormwater from roof drainage from entering certain buildings.

3.3.5 Rainfall intensity

3.3.5.1 Australia

Five minutes duration rainfall intensity, in millimetres per hour, for any place in Australia shall be determined for—

- (a) ARIs of 20 and 100 years, from Appendix E; and
- (b) ARI of 500 years, assumed to be 1.5 times the 100 years ARI intensity at the same place.

NOTE: Guidelines for the determination of rainfall intensity are given in Appendix D.

3.3.5.2 New Zealand

Ten minutes duration rainfall intensity, in millimetres per hour, for any place in New Zealand shall be determined for ARIs of 10 and 50 years, from Appendix F.

NOTE: Guidelines for the determination of rainfall intensity are given in Appendix D.

3.4 CATCHMENT AREA

3.4.1 General

The catchment area for a roof, or roof and vertical wall(s), depends upon the gradient of the descent of the rain (see Clause 3.3.3) and shall be the greatest value for any direction of wind-driven rain.

NOTE: It may be necessary to trial different directions for the wind-driven rain to determine the catchment area for a particular case.

The components of the largest catchment area for a single dwelling (see Paragraph H2, Appendix H) shall be calculated by one of the following methods:

- (a) Rational analysis.
- (b) Application of Clauses 3.4.2 to 3.4.4, inclusive.

3.4.2 Three-dimensional representation

A three-dimensional representation of the two components A_h and A_v of the catchment area for a sloping roof with its top edge either horizontal or not horizontal is shown in Figure 3.1. These components are represented in Figures 3.2 and 3.3 by lines in the horizontal and vertical planes.

3.4.3 Roof

The catchment area, in square metres, of—

- (a) a flat roof that is freely exposed to the wind shall be equal to the plan area of the roof and gutter(s);
- (b) a single sloping roof that is—

- (i) freely exposed to the wind (see Figure 3.3(a)) shall be calculated from—

$$A_c = A_h + 1/2 A_v \text{ or,} \quad \dots 3.4.3(1)$$

for eaves gutters only

$$A_c = A_h F \quad \dots 3.4.3(2)$$

(For values of F , see Table 3.2.)

NOTE: F is accurate in most cases and conservative in others.

- (ii) partially exposed to the wind (see Figure 3.3(b)) shall be calculated from—

$$A_c = A_h + 1/2 (A_{v2} - A_{v1}) \quad \dots 3.4.3(3)$$

- (c) two adjacent sloping roofs (see Figure 3.3(c)) shall be calculated from—

$$A_c = A_{h1} + A_{h2} + 1/2 (A_{v2} - A_{v1}) \quad \dots 3.4.3(4)$$

NOTE: Equation 3.4.3(2) may be applied to the plan area of a roof (A_h) of a dwelling regardless of the wind direction provided that there is no vertical surface that contributes to the catchment area (see Appendix H).

TABLE 3.2
CATCHMENT AREA—SLOPE FACTOR (*F*) (FOR EAVES GUTTERS ONLY)

| Roof slope (degrees) | Factor for increased surface area of roof (<i>F</i>) | Roof slope (degrees) | Factor for increased surface area of roof (<i>F</i>) | Roof slope (degrees) | Factor for increased surface area of roof (<i>F</i>) |
|----------------------|--|----------------------|--|----------------------|--|
| 0 | 1.00 | 22 | 1.20 | 44 | 1.48 |
| 1 | 1.01 | 23 | 1.21 | 45 | 1.50 |
| 2 | 1.02 | 24 | 1.22 | 46 | 1.52 |
| 3 | 1.03 | 25 | 1.23 | 47 | 1.54 |
| 4 | 1.03 | 26 | 1.24 | 48 | 1.56 |
| 5 | 1.04 | 27 | 1.25 | 49 | 1.58 |
| 6 | 1.05 | 28 | 1.27 | 50 | 1.60 |
| 7 | 1.06 | 29 | 1.28 | 51 | 1.62 |
| 8 | 1.07 | 30 | 1.29 | 52 | 1.64 |
| 9 | 1.08 | 31 | 1.30 | 53 | 1.66 |
| 10 | 1.09 | 32 | 1.31 | 54 | 1.69 |
| 11 | 1.10 | 33 | 1.32 | 55 | 1.71 |
| 12 | 1.11 | 34 | 1.34 | 56 | 1.74 |
| 13 | 1.12 | 35 | 1.35 | 57 | 1.77 |
| 14 | 1.12 | 36 | 1.36 | 58 | 1.80 |
| 15 | 1.13 | 37 | 1.38 | 59 | 1.83 |
| 16 | 1.14 | 38 | 1.39 | 60 | 1.87 |
| 17 | 1.15 | 39 | 1.40 | 61 | 1.90 |
| 18 | 1.16 | 40 | 1.42 | 62 | 1.94 |
| 19 | 1.17 | 41 | 1.43 | 63 | 1.98 |
| 20 | 1.18 | 42 | 1.45 | 64 | 2.03 |
| 21 | 1.19 | 43 | 1.47 | 65 | 2.07 |

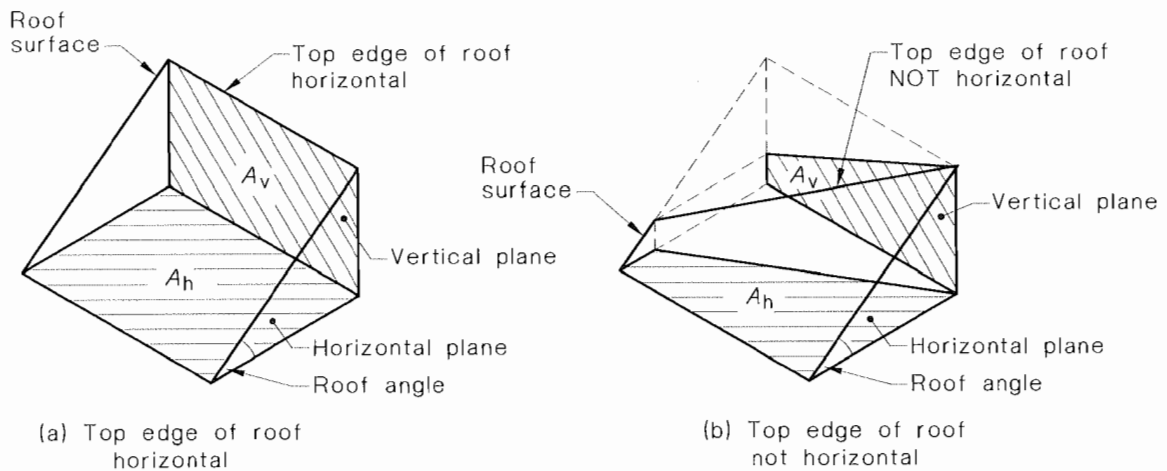
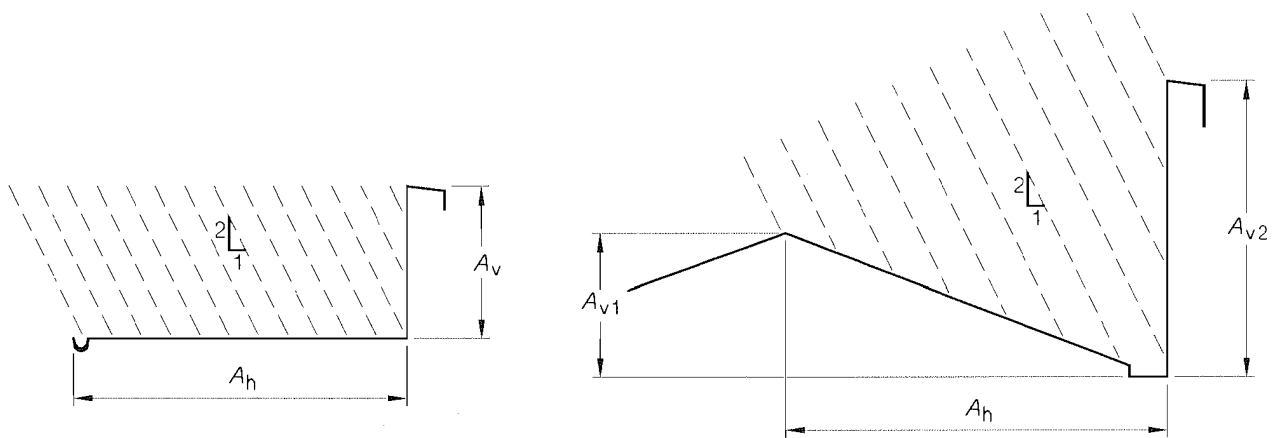
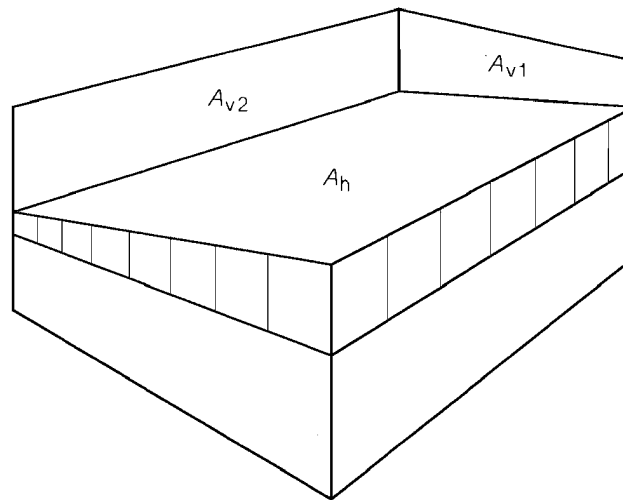

FIGURE 3.1 COMPONENTS OF THE CATCHMENT AREA



(a) Vertical wall with flat roof

(b) Vertical wall with sloping roof



(c) Vertical walls at right angles to each other

FIGURE 3.2 CATCHMENT AREA FOR VERTICAL WALL(S) AND ROOF

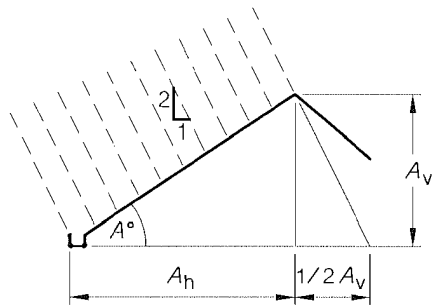

(a) Single sloping roof — freely exposed to the wind

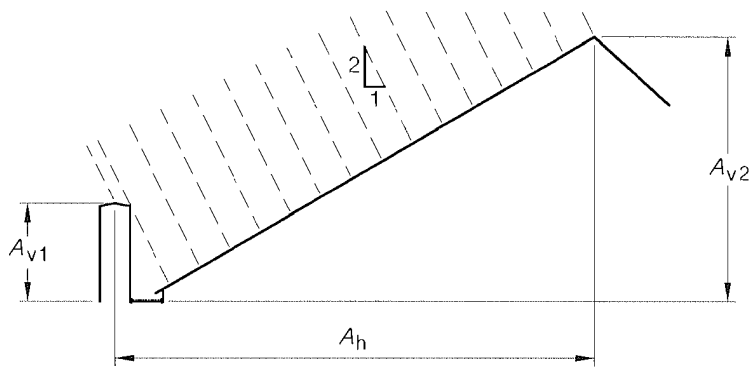

(b) Single sloping roof — partially exposed to the wind

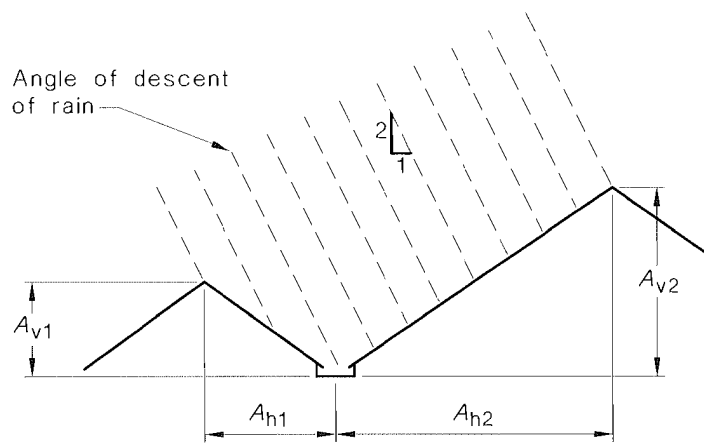

(c) Two adjacent sloping roofs

FIGURE 3.3 CATCHMENT AREA FOR ROOFS

3.4.4 Vertical wall(s) and roof

The catchment area, in square metres, for—

(a) vertical wall with a—

(i) flat roof (see Figure 3.2(a)) shall be calculated from—

$$A_c = A_h + 1/2 A_v \quad \dots 3.4.4(1)$$

(ii) sloping roof (see Figure 3.2(b)) shall be calculated from—

$$A_c = A_h + 1/2 (A_{v2} - A_{v1}) \quad \dots 3.4.4(2)$$

(b) vertical walls at right angles to each other (see Figure 3.2(c)) shall be calculated from—

$$A_c = A_h + 1/2 (A_{v1} + A_{v2}) \quad \dots 3.4.4(3)$$

NOTE: The catchment area for high vertical walls, e.g., a multistorey building, may be considerably less than half its surface area.

3.4.5 Higher catchment area

Stormwater from a higher catchment area shall be discharged direct to an appropriately sized rainhead or sump.

Alternatively a spreader, may be used subject to the following:

- (a) For a tiled roof the lower section shall be sarked a minimum width of 1800 mm, either side from the point of discharge, and extended down to the eaves gutter in accordance with AS 2050.
- (b) For a corrugated metal roof a minimum width of 1800 mm on either side of the point of discharge shall be sealed for full length of side laps.

In all cases the downpipe and gutter system of the lower catchment shall be sized in accordance with Clause 3.4 to take into account the total flow from both catchments.

NOTES:

- 1 The rainhead or sump may need to be larger than those sized in accordance with this Standard and include an appropriate device to dissipate energy. Sizing of such a rainhead or sump is beyond the scope of this Standard and may require hydraulic tests.
- 2 Where spreaders are used, an allowance for an increased overflow provision for the gutter on the lower catchment should be considered.
- 3 For a tiled roof consideration should be given to sarking the roof below any upper eaves gutters to take into account any overflows.

3.5 EAVES GUTTER SYSTEMS

3.5.1 General

Eaves gutter systems, including downpipes, shall be designed and installed in accordance with Clause 3.2 so that water will not flow back into the building.

3.5.2 Design procedure

The design procedure shall follow the general method for design of eaves gutters systems flow chart, in Figure 3.4.

NOTE: An example of the application of the design procedure is given in Appendix H.

3.5.3 Overflow measures

Note: Examples of overflow measures for eaves gutters are given in Appendix G.

3.5.4 Vertical downpipes

Gutter outlets shall be fitted vertically to the sole of eaves gutters.

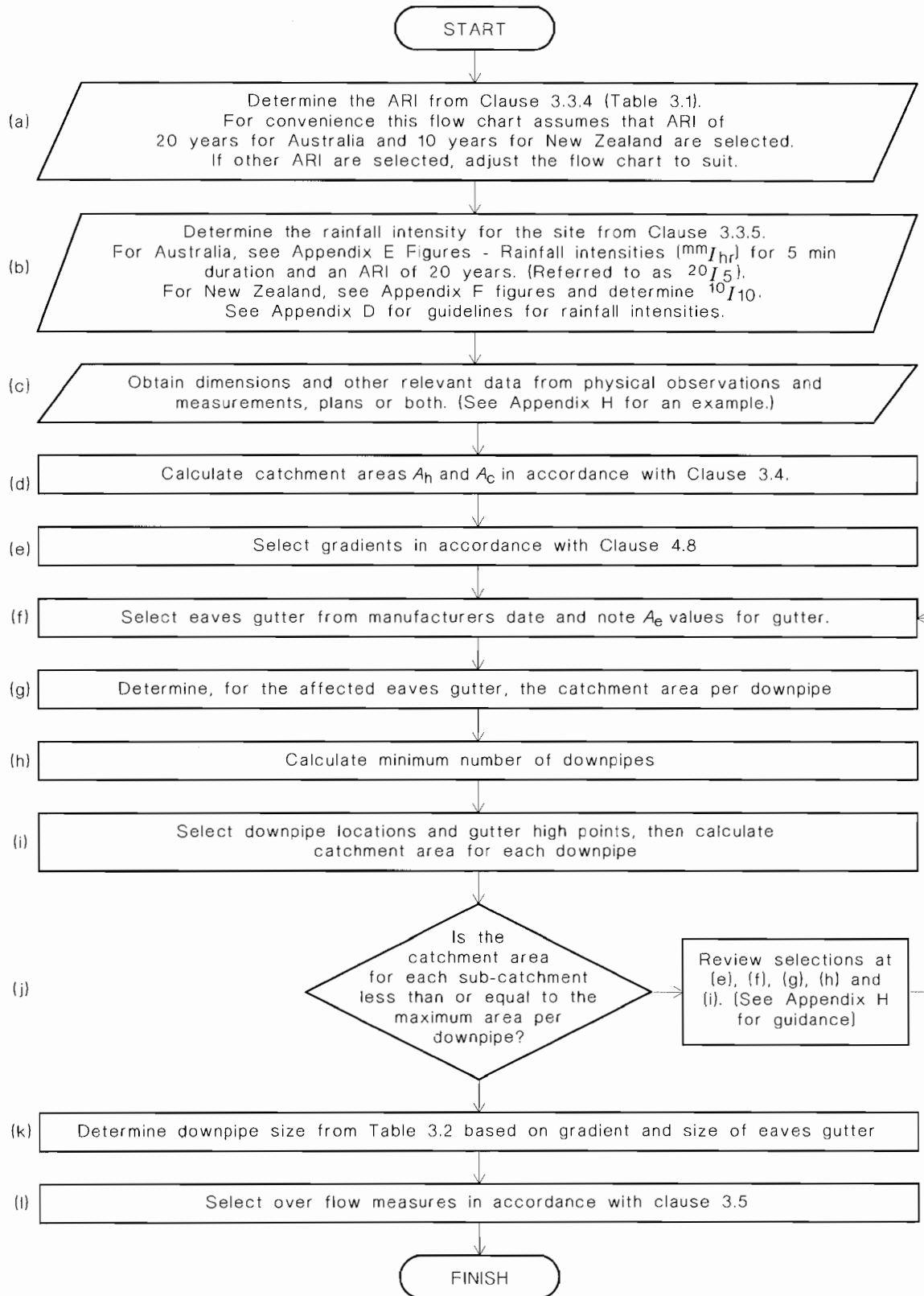

FIGURE 3.4 (in part) FLOW CHART—GENERAL METHOD FOR DESIGN OF EAVES-GUTTER SYSTEMS

NOTES:

- 1 The letter in a bracket at the head of each symbol refers to the corresponding step in the example (see Paragraph H2.2, Appendix H).
- 2 Appendix D gives guidelines for the determination of rainfall intensities.
- 3 A_e to be in the range for gradients of—
 - (a) 1:500 and steeper, 3000 mm² to 18 000 mm²; or
 - (b) flatter than 1:500, 4000 mm² to 24 200 mm².
- 4 Consideration needs to be given to the criteria for thermal variation (see Clause 4.3).
- 5 For eaves gutters of domestic buildings with hipped and/or gable roofs of constant slope with no flat roofs or walls contributing to the catchment area, the catchment area calculations may be based entirely on Equation 3.4.3 (2) using F determined by the roof slope and A_h determined from a plan. If Equation 3.4.3 (2) is used, it is not necessary to take account of wind direction. Examples of the use of this method are shown in Appendix H and in HB114.
- 6 The vertical downpipe and any horizontal bends in an eaves gutter may be located at any point along the length of the catchment. Where this occurs, the whole catchment to that downpipe shall be used with Figure 3.5a or Figure 3.5b (gutters less than 1:500) to size the eaves gutter to ensure that the vertical downpipe size is sufficient.
- 7 As there are no high points for flat eaves gutters to define the catchment areas for each downpipe and downpipe section, halve the total catchment area between the adjacent downpipes.
- 8 For aesthetic and practical considerations, the size of eaves gutter and associated vertical downpipes for the largest catchment area of the building are usually adopted for each of the other catchments.

A1

FIGURE 3.4 (in part) FLOW CHART—GENERAL METHOD FOR DESIGN OF EAVES GUTTER SYSTEMS

TABLE 3.3
EAVES GUTTER—REQUIRED SIZE OF VERTICAL DOWNPIPE

| Maximum effective cross-sectional area of an eaves gutter (A_e), see AS/NZS 2179.1. (Required effective cross-sectional area is obtained from Figure 3.5) Nearest 100 mm ² | | Internal size of vertical downpipe mm | |
|---|--------------------|--|-----------------------|
| Gradient | | Cross-section | |
| 1:500 and steeper | Flatter than 1:500 | Circular | Rectangular or square |
| 3 500 | 4 700 | 65 | 65 × 50 |
| 4 200 | 5 600 | 75 | 65 × 50 |
| 4 600 | 6 200 | 75 | 75 × 50 |
| 4 800 | 6 400 | 80 | 75 × 50 |
| 5 200 | 7 000 | 80 | 100 × 50 |
| 5 900 | 7 900 | 85 | 100 × 50 |
| 6 400 | 8 600 | 90 | 100 × 50 |
| 6 600 | 8 900 | 90 | 75 × 70 |
| 6 700 | 9 000 | 100 | 75 × 70 |
| 8 200 | 11 000 | 100 | 100 × 75 |
| 9 600 | 12 900 | 125 | 100 × 75 |
| 12 800 | 17 100 | 125 | 100 × 100 |
| 12 800 | 17 200 | 150 | 100 × 100 |
| 16 000 | 21 500 | 150 | 125 × 100 |
| 18 400 | 24 700 | 150 | 150 × 100 |
| 19 200 | 25 800 | — | 150 × 100 |
| 20 000 | 26 800 | — | 125 × 125 |

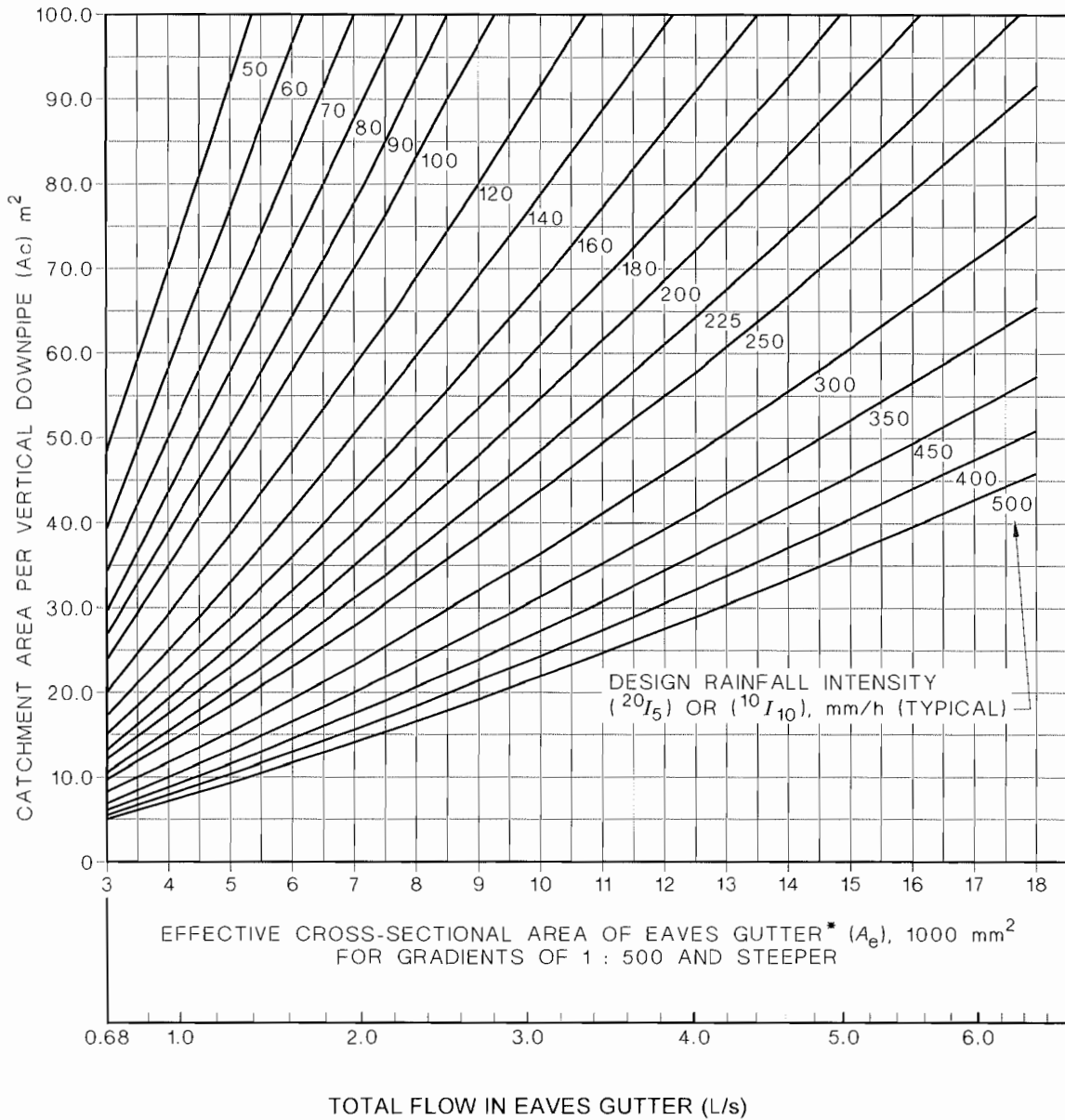

* See AS/NZS 2179.1.

NOTES:

- 1 This graph assumes—
 - (a) an effective width to depth is a ratio of about 2:1;
 - (b) a gradient in the direction of flow, 1:500 or steeper;
 - (c) the least favourable positioning of the downpipe and bends within the gutter length;
 - (d) a cross-section of half round, quad, ogee or square; and
 - (e) the outlet to a vertical downpipe is located centrally in the sole of the eaves gutter.
- 2 The required eaves gutter discharge areas do not allow for loss of waterway due to internal brackets.

FIGURE 3.5(A) REQUIRED SIZE OF EAVES GUTTERS FOR GRADIENTS FOR 1:500 AND STEEPER

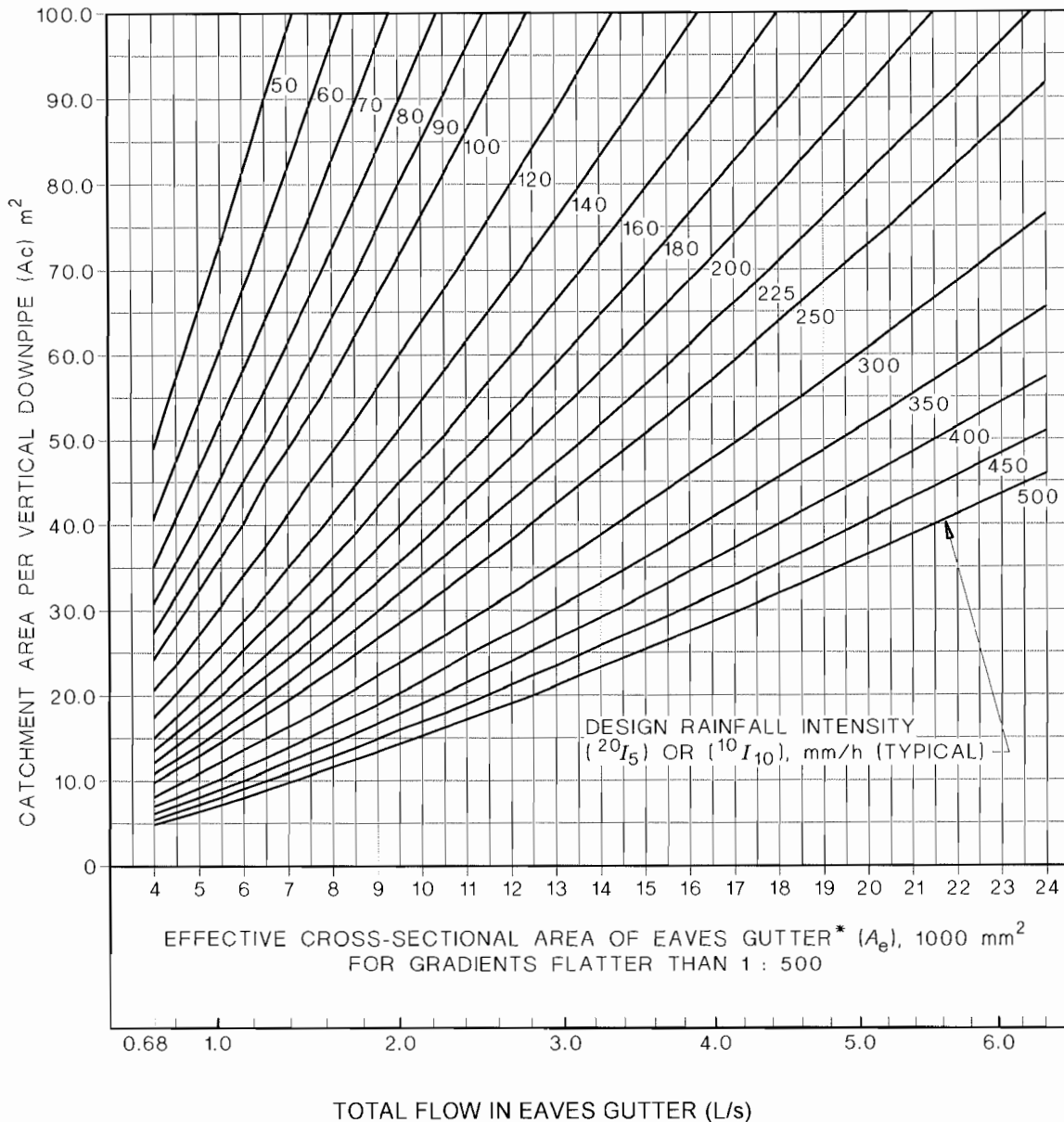

* See AS/NZS 2179.1.

NOTES:

- 1 This graph assumes—
 - (a) an effective width to depth is a ratio of about 2:1;
 - (b) a gradient in the direction of flow flatter than 1:500;
 - (c) the least favourable positioning of the downpipe and bends within the gutter length;
 - (d) a cross-section or half round, quad, ogee or square; and
 - (e) the outlet to a vertical downpipe is located centrally in the sole of the eaves gutter.
- 2 The required eaves gutter discharge areas do not allow for loss of waterway due to internal brackets.

FIGURE 3.5(B) REQUIRED SIZE OF EAVES GUTTERS FOR GRADIENTS FLATTER THAN 1:500

3.5.5 Effective cross-sectional area of eaves gutters

The effective cross-sectional area of an eaves gutter (to the nearest 100 mm²) for each nominal size of eaves gutter shall be as follows:

- (a) For an eaves gutter with external brackets, it is the cross-sectional area beneath a line not less than 10 mm below the overflow, e.g., front bead, gutter back or bottom of overflow slots; or
- (b) For an eaves gutter with internal brackets, it is as for Figure 3.5(A) or 3.5(B) less the allowance for the effects of the brackets.

NOTES:

- 1 The cross-sectional area of the eaves gutter and the effect of internal brackets should be available from the manufacturer.
- 2 The method specified in this Standard for the sizing of eaves gutters is based on research using eaves gutters with external brackets.
- 3 Internal brackets increase the potential for debris collection.
- 4 Where the manufacture does not provide data on the effect of the internal bracket, the projected gross area of the edge of the internal bracket including stiffening rib facing the direction of flow may be deducted, provided that the area so deducted is no more than 15% of the original cross sectional area of the gutter.

3.6 VALLEY GUTTERS

3.6.1 Limitations

The limitations of the general method's solutions for valley gutters are—

- (a) roof slopes of not less than 1:4.5 (12.5°);
- (b) nominal valley gutter side angle (see Figure 3.6) of 1:3.4 (16.5°); and
- (c) catchment area not exceeding 20 m².

3.6.2 Design procedure

The method of design for valley gutters shall be as follows:

- (a) Select from Table 3.1 the ARI for the particular application.
- (b) Determine the design rainfall intensity, in millimetres per hour, for the particular location in Australia, from Appendix E or New Zealand from Appendix F for the selected ARI.

NOTE: Appendix D gives guidelines for the determination of rainfall intensities.

- (c) The girth size and dimensions (see Figure 3.6) shall be as given in Table 3.4 for the design rainfall intensity.

NOTE: Table 3.4 is derived from the Martin and Tilley Report (see Paragraph A2, Appendix A). Further research when completed will be considered for adoption in the Standard.

3.6.3 Effective width

The effective width (w_e) of a valley gutter shall be such that the effective cross-sectional area of valley gutters, below the effective width (see Figure 3.6), are not obstructed by bedding, anti-vermin strips, or overhangs of roof cladding.

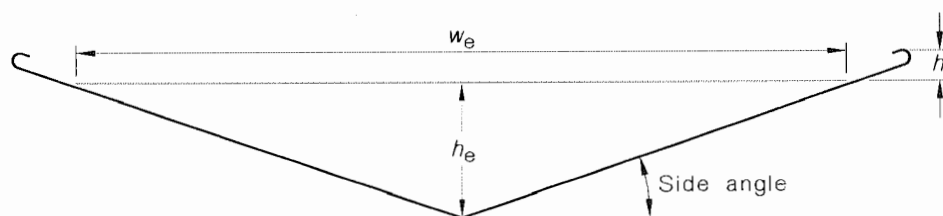

FIGURE 3.6 PROFILE OF A VALLEY GUTTER

TABLE 3.4
VALLEY GUTTERS—DIMENSIONS

| Design rainfall intensity (see Clause 3.6.2 (b)) mm/h | | Minimum, mm | | |
|---|------------|-------------|---------------------------|---------------------------|
| | | Sheet width | Effective depth (h_e) | Effective width (w_e) |
| | ≤ 200 | 355 | 32 | 215 |
| >200 | ≤ 250 | 375 | 35 | 234 |
| >250 | ≤ 300 | 395 | 38 | 254 |
| >300 | ≤ 350 | 415 | 40 | 273 |
| >350 | ≤ 400 | 435 | 43 | 292 |

NOTES:

- 1 Freeboard (h_f), 15 mm.
- 2 The sheet width from which the valley is to be formed has been calculated on the basis of $h_f = 15$ mm and an allowance for side rolls or bends of 25 mm.

3.7 BOX GUTTER SYSTEMS

3.7.1 General

The limitation of solutions for—

- (a) box gutters, is gradients in the range 1:40 to 1:200 (see Note 1);
- (b) rainheads is —
 - (i) design flows not to exceed 16 L/s;
 - (ii) size range of vertical downpipes according to Figure I3, Appendix I; and
- (c) sumps with appropriate overflow devices, is the size range of vertical downpipes according to Figure I4, Appendix I.

NOTES:

- 1 Figures I6 and I8, Appendix I, assume that box gutters slope in the range 1:40 to 1:200.
- 2 Criteria for box gutter overflow devices are given in Clause 3.7.5 and are illustrated in Figure 3.7.
- 3 The minimum width of box gutters used for commercial construction is 300 mm. Box gutters 200 mm wide may be used for domestic construction, but they are more prone to blockages and should be subject to frequent inspections and maintenance. Additional height is recommended where possible.

3.7.2 Design procedure

Box gutter systems shall be designed in accordance with the general method. The general method for—

- (a) box gutters, rainheads and downpipes is given in Figure 3.8.
- (b) box gutters, sump/side overflow devices and downpipes is given in Figure 3.9.
- (c) box gutters, sump/high-capacity overflow devices and downpipes is given in Figure 3.10.

NOTE: Flow chart symbols and conventions used in this Standard are given in Clause 1.4.2.

3.7.3 Hydraulic capacity

The hydraulic capacity, e.g., maximum design flow of—

- (a) a box gutter is dependent on—
 - (i) the sole width and gutter depth;
 - (ii) the gradient (see Clause 4.9(a)); and
 - (iii) whether the discharge is to—
 - (A) a rainhead;
 - (B) a sump/side overflow device; or
 - (C) a sump/high-capacity overflow device; and
- (b) an associated rainhead or sump is dependent on the selected size of the vertical downpipe and the depth of the rainhead or sump (see Figures 3.9, 3.10 and 3.11).

NOTE: For the same design flow, the required depth of a rainhead or sump increases if the cross-sectional area of the vertical downpipe decreases.

3.7.4 Layout

The layout for box gutter systems shall include consideration for the following:

- (a) The location and size (see Clause 3.7.2) of the box gutter.
- (b) The size (see Clause 4.16) of the support system.
- (c) Adequate provision for the effects of thermal variation (see Clause 4.3) on the box gutter and support system.
- (d) The location of associated vertical downpipes with rainheads or sumps in relation to—
 - (i) features within the building and usage;
 - (ii) surface water drainage system external to the building (see Clause 5.3);
 - (iii) the space within or external to the building; and
 - (iv) provision for flow from each overflow device (see Clause 3.7.5) to be discharged, without danger, indirectly to the surface water drainage system.
- (e) The sump/high capacity overflow device—the depth of the sump h_s shall be not less than 150 mm regardless of the position of the normal outlet. (No changes if sump/side overflow device used).
- (f) The normal outlet may be moved longitudinally to clear the overflow channel to enable better inspection and maintenance access. The outlet shall not be moved laterally to cross the longitudinal centre-line of the overflow device.

NOTE: If the normal outlet is moved, it should preferably be moved towards the box gutter with the greater flow.

- (g) Box gutters shall—
- (i) be straight (without change in direction);
 - (ii) in a cross-section have a horizontal constant width base (sole) with vertical sides;
 - (iii) have a constant longitudinal slope between 1:200 and 1:40;
 - (iv) discharge at the downstream end without change of direction (i.e., not to the side); and
 - (v) be sealed to the rainheads and sumps.

3.7.5 Overflow devices

3.7.5.1 Hydraulic capacity

The hydraulic capacity of an overflow device shall be not less than the design flow for the associated gutter outlet. Overflow devices shall discharge to the atmosphere.

3.7.5.2 Operation

Overflow devices that discharge from—

- (a) rainheads do not require an increase in the depth of flow in the box gutter (see Figure 3.7(a));
- (b) sumps do require an increase in the depth of flow in the box gutter and are either—
 - (i) side overflow (see Figure 3.7(b)); or
 - (ii) high-capacity overflow (see Figure 3.7(c)) where in the event of a blockage in the normal vertical downpipe A the water level in the primary sump B will rise to and overtop the overflow weirs C1 and C2 (each weir length equal to the width of the adjacent box gutter) to flow either directly, or indirectly by the overflow channel D, to the secondary sump E and then to the overflow vertical downpipe F.

- 1 A vertical pipe overflow, where for example downpipe F (Figure 3.7(c)) projects through the floor of the sump, is a possible alternative where a high-capacity device is not required. No equations, graphs or examples are provided for vertical pipe overflow devices due to a lack of appropriate research data. It is recommended that vertical pipe overflows be designed by suitably qualified competent persons taking into account the water profile in the gutter upstream of the overflow device.
- 2 Where water flowing directly into the overflow is a problem, a deflector or cap may be installed to divert the water.

3.7.6 Downpipes

Downpipes shall—

- (a) be fitted vertically to the base of a rainhead or sump; and
- (b) discharge to—
 - (i) a rainhead or sump of a lower gutter (see Clause 3.4.5); or
 - (ii) the surface water drainage system.

3.8 SOAKERS

NOTE: Data for the design of soakers is the subject of research and when available will be considered for adoption in the Standard.

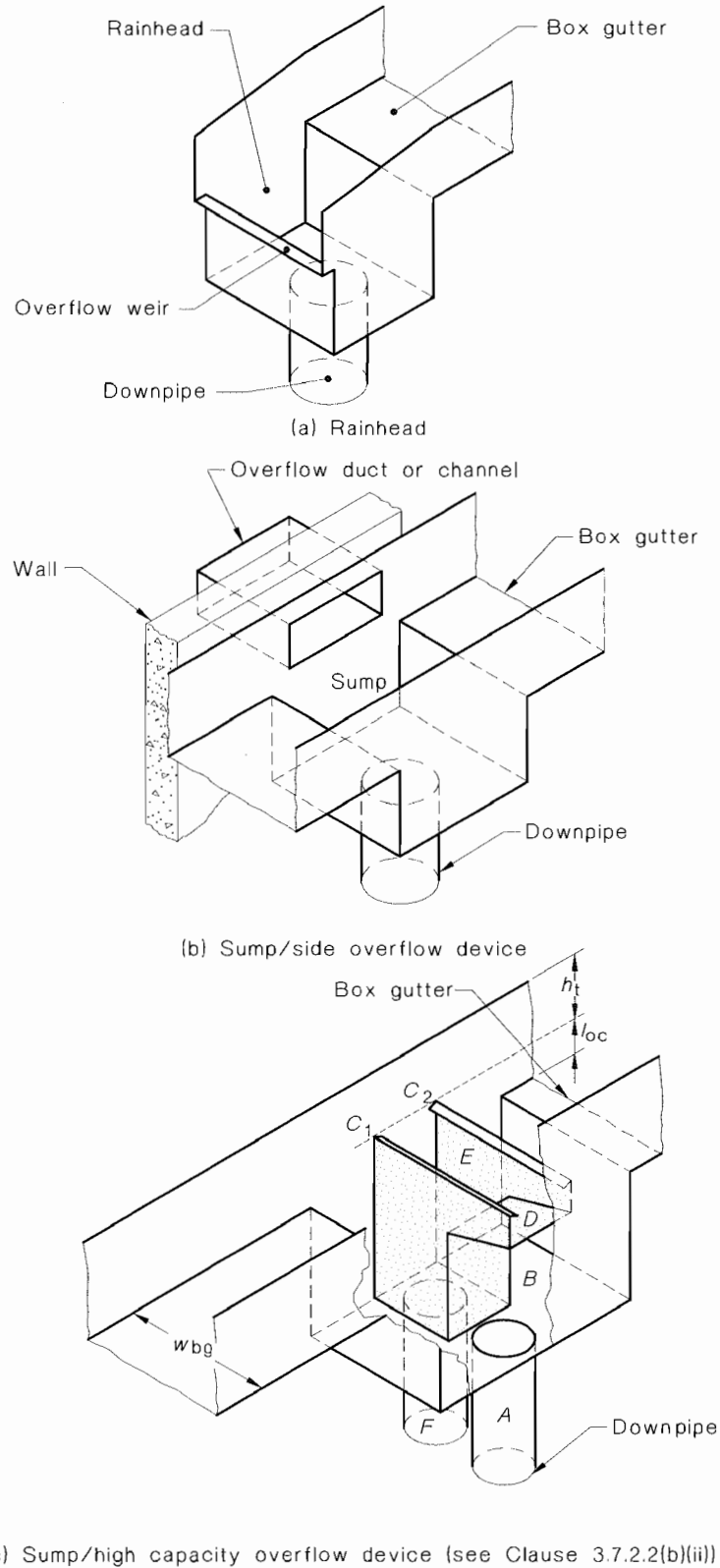

NOTES:

- 1 Layout of sump/side overflow device may have to be varied due to constraints (see Figure 3.7(b)).
- 2 Where desired, the sides of the sump/high-capacity overflow device may be perforated to flush the downpipe (F) (see Figure 3.7(c)).
- 3 The normal outlet may be moved longitudinally to enable better inspection and maintenance access (see Clause 3.7.4 (f)) (see Figure 3.7 (c)).
- 4 For criteria for overflow devices see Clause 3.7.5.

FIGURE 3.7 OVERFLOW DEVICES—BOX GUTTERS

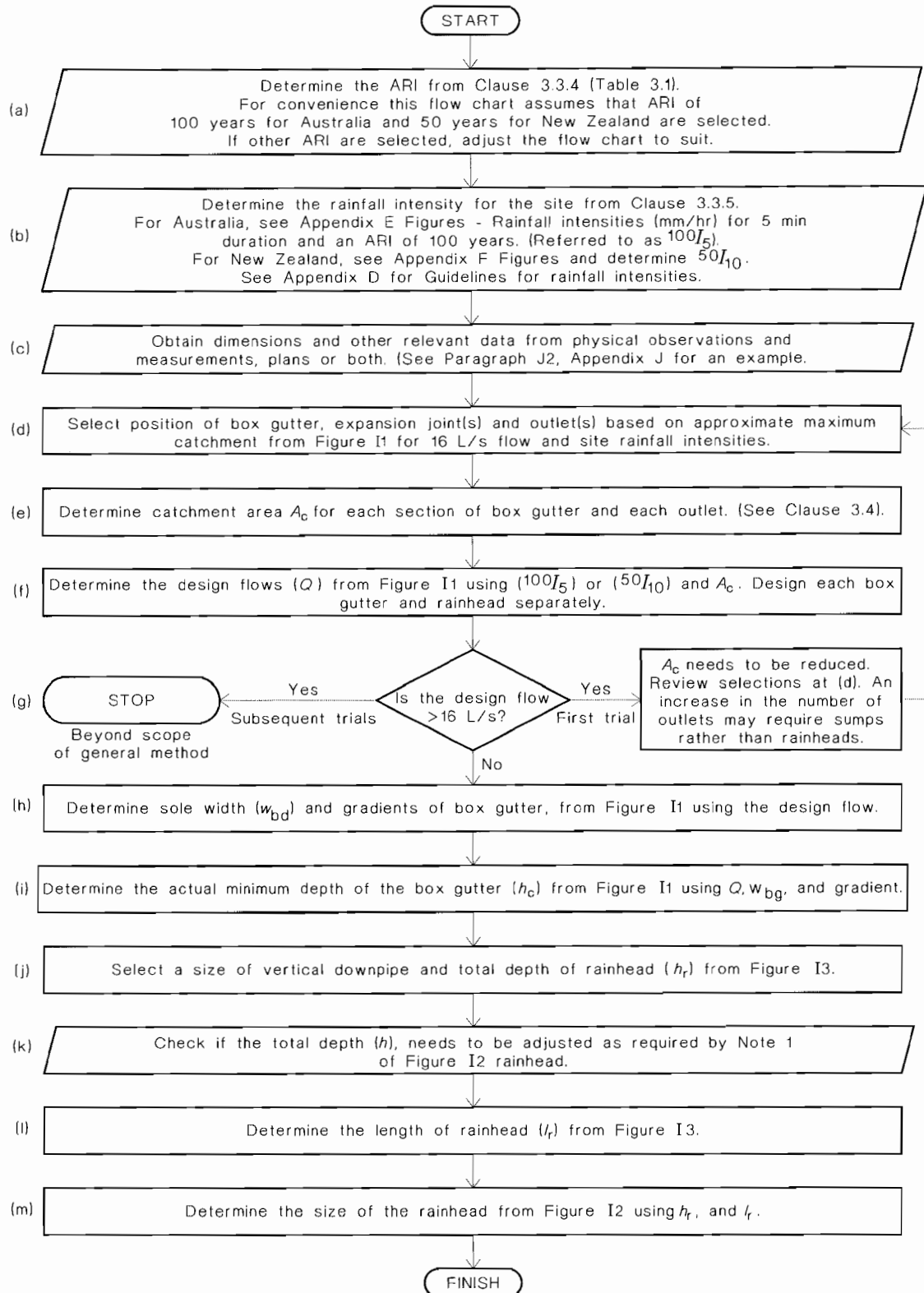

NOTES:

- 1 Selected positions of box gutter, expansion joint(s), rainheads, downpipes and overflow devices shall be compatible with the layout of buildings and site stormwater drains and the criteria for thermal variation (see Clause 4.3).
- 2 Figure I3 is for a box gutter with a gradient of 1:200. For steeper gradients, determine from Figure I1, for the design flow, the equivalent total depth of box gutter with a gradient of 1:200. Determine from Figure I3, for the equivalent total depth, the increased l_r .

FIGURE 3.8 FLOW CHART—GENERAL METHOD FOR DESIGN OF BOX GUTTERS, RAINHEADS AND DOWNPIPES

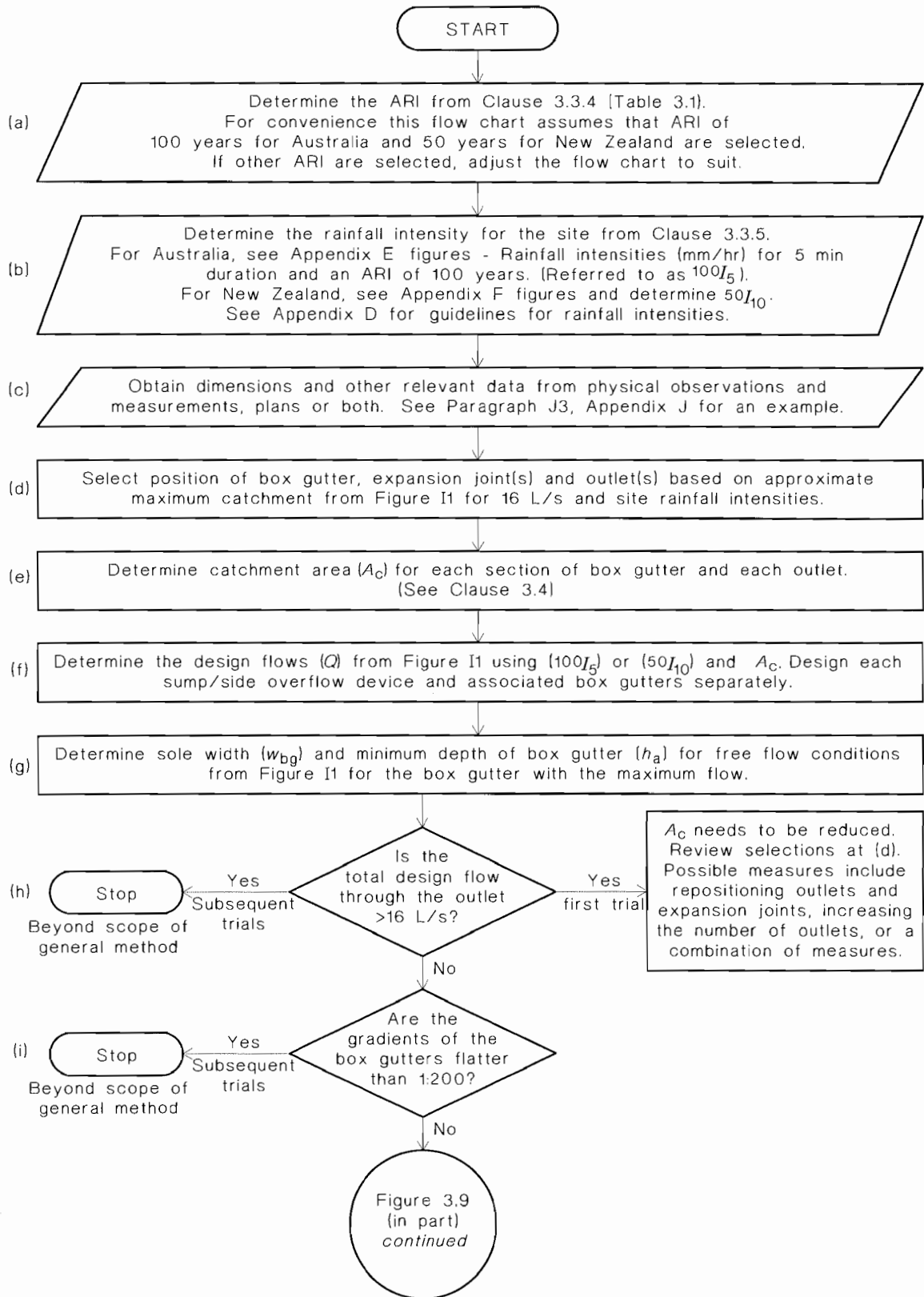
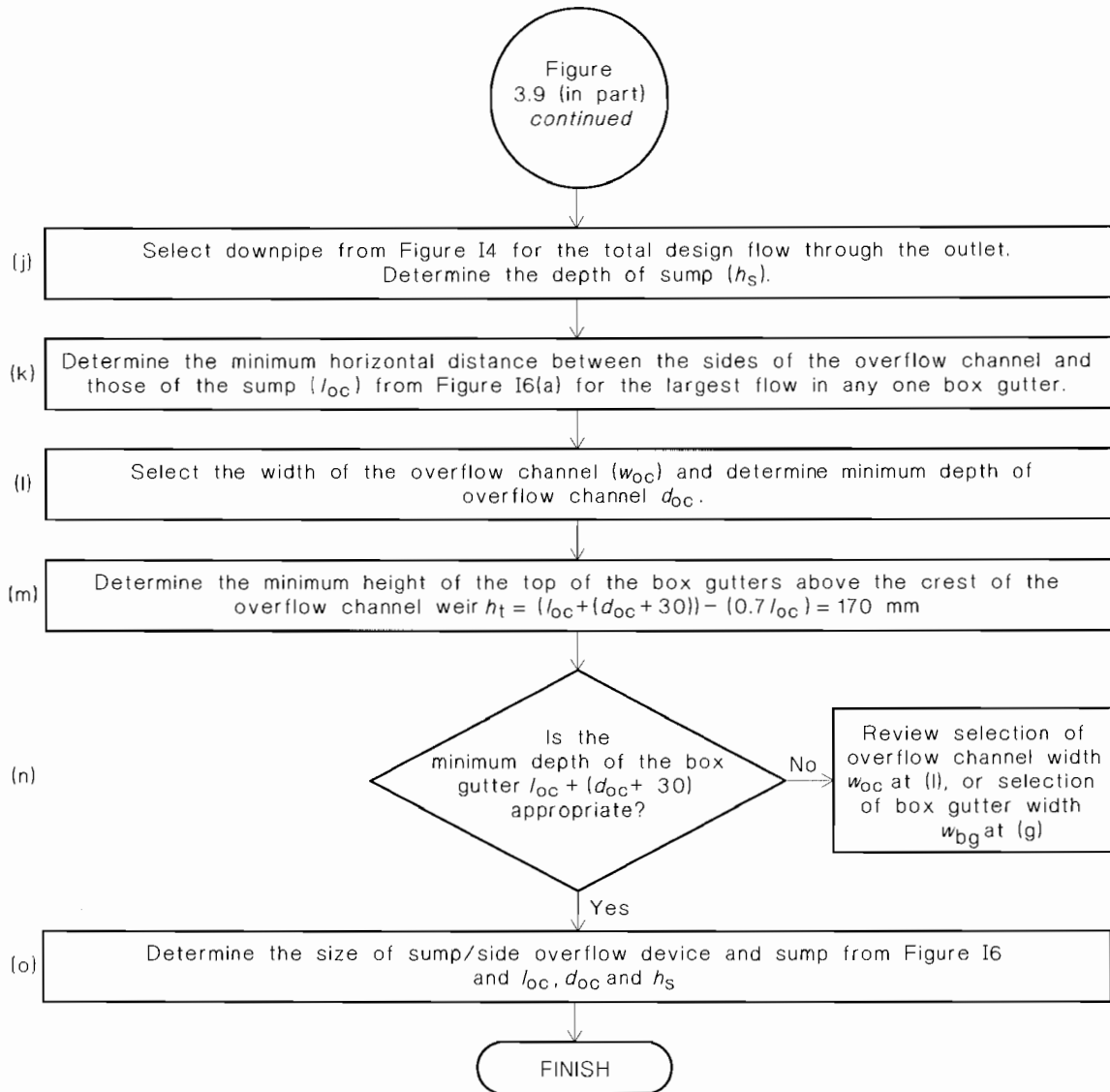

FIGURE 3.9 (in part) FLOW CHART—GENERAL METHOD FOR DESIGN OF BOX GUTTERS, SUMP/SIDE OVERFLOW DEVICES AND DOWNPIPES



NOTES:

- 1 Selected positions of box gutter, expansion joint(s), sumps, downpipes and overflow devices to be compatible with the layout of buildings and site stormwater drains and the criteria for thermal variation (see Clause 4.3).
- 2 The total design flow is the summation of the design flow for each box gutter and the section of roofing discharged directly into the sump.

FIGURE 3.9 (in part) FLOW CHART—GENERAL METHOD FOR DESIGN OF BOX GUTTERS, SUMP/SIDE OVERFLOW DEVICES AND DOWNPIPES

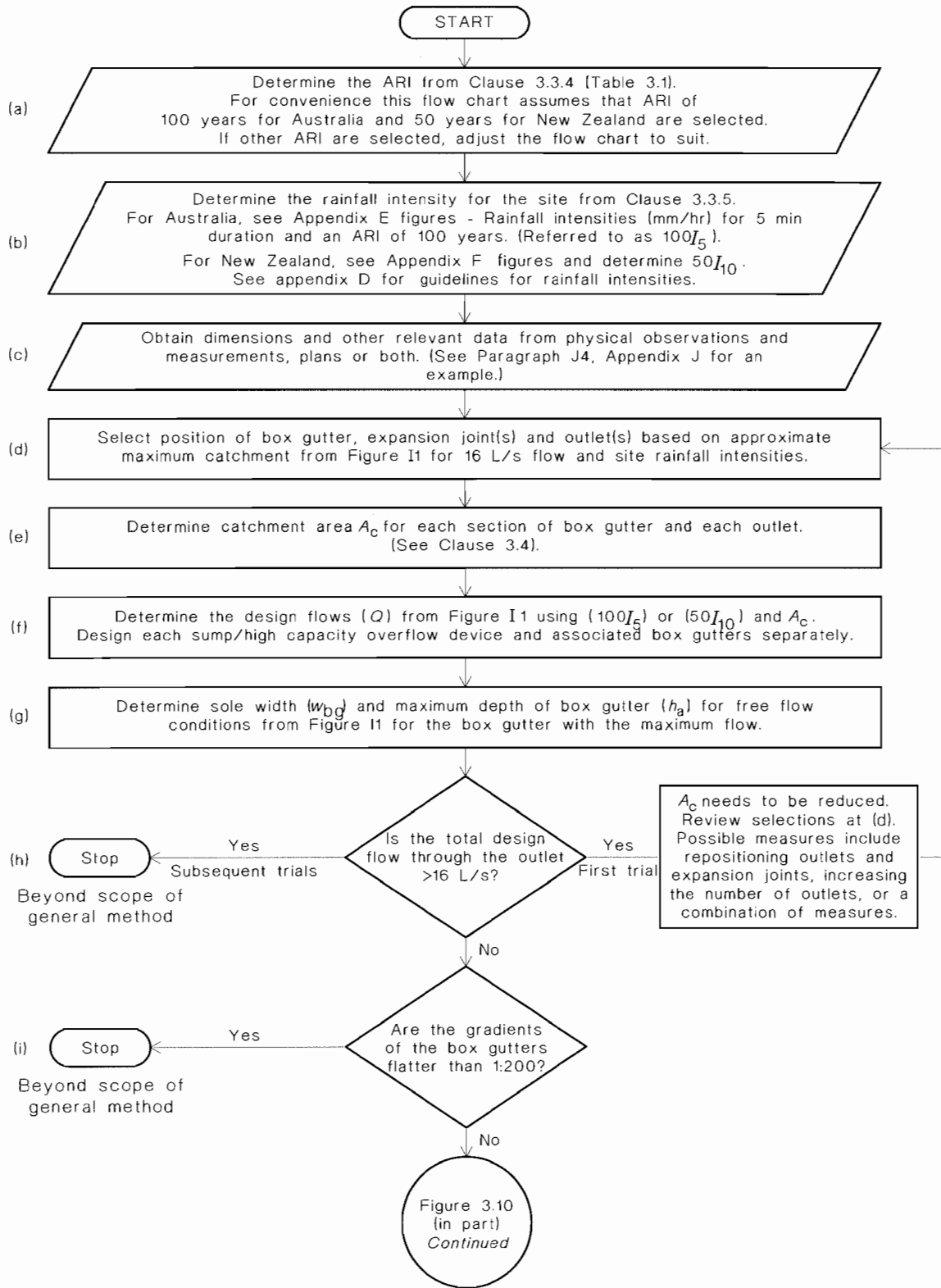
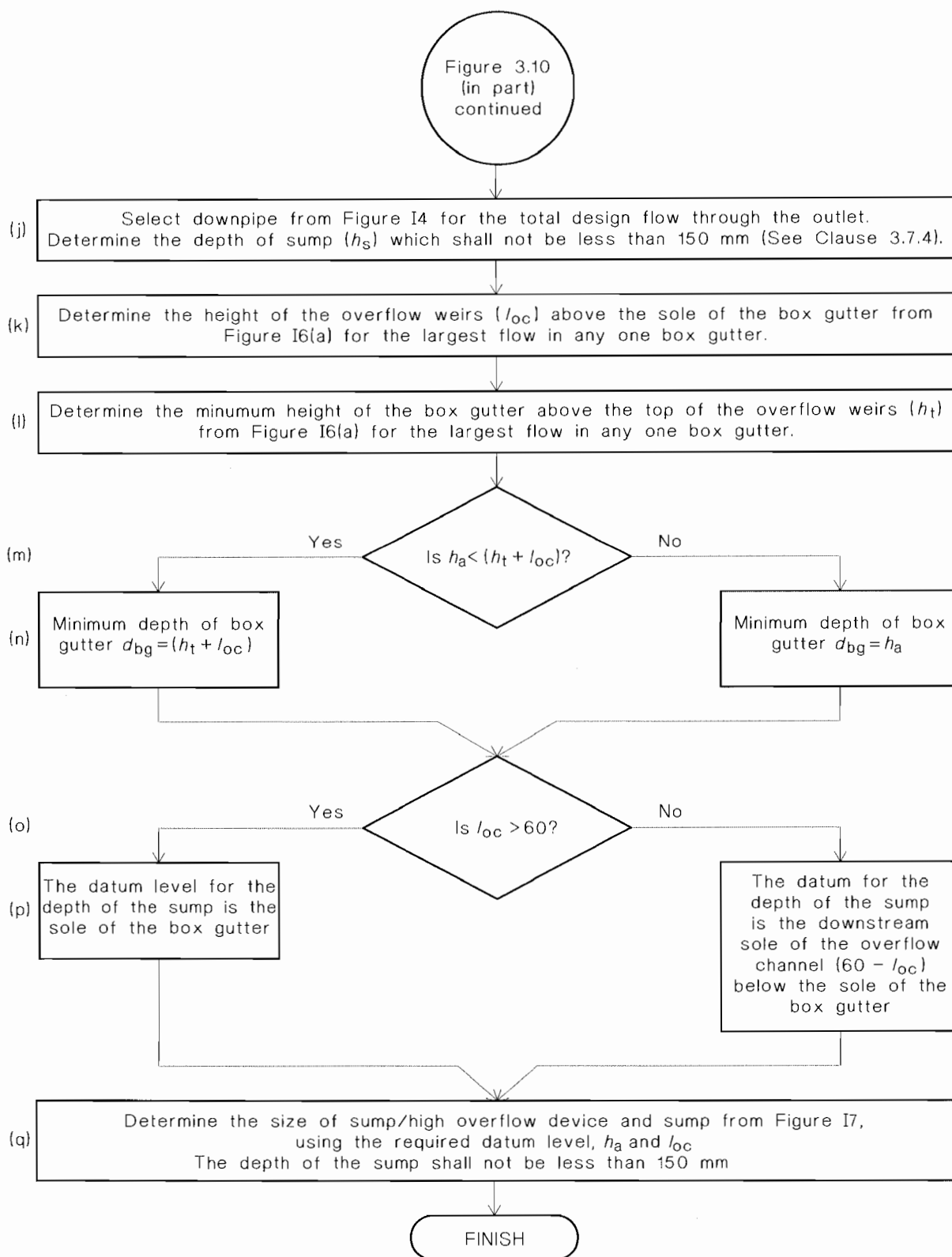

FIGURE 3.10 (in part) FLOW CHART—GENERAL METHOD FOR DESIGN OF BOX GUTTERS, SUMP/HIGH-CAPACITY OVERFLOW DEVICES AND DOWNPIPES



NOTES:

- 1 Selected positions of box gutter, expansion joint(s), sumps, downpipes and overflow devices shall be compatible with the layout of buildings and site stormwater drains and the criteria for thermal variation (see Clause 4.3).
- 2 The total design flow is the summation of the design flow for each box gutter and the section of roofing discharged directly into the sump.

FIGURE 3.10 (in part) FLOW CHART—GENERAL METHOD FOR DESIGN OF BOX GUTTERS, SUMP/HIGH-CAPACITY OVERFLOW DEVICES AND DOWNPIPES

SECTION 4 ROOF DRAINAGE SYSTEMS — INSTALLATIONS

4.1 SCOPE OF SECTION

This Section specifies installation requirements for roof drainage systems.

4.2 TRANSPORT, HANDLING AND STORAGE

4.2.1 General

Roof drainage system components and support systems shall be transported, handled and stored with care so that no damage occurs during these operations. When stored on site they shall be in sheltered and secure positions.

4.2.2 Strippable polymer coating

Strippable polymer coatings shall be removed from components during installation.

4.3 THERMAL VARIATION

4.3.1 General

Where thermal variation of roof drainage system components or support systems, or both, would otherwise have a deleterious effect, adequate provision shall be made to accommodate such variation. Where thermal variation is to be controlled, the restraint shall be limited to one fixed point per section and due allowance shall be made for the forces that will be imposed by it.

4.3.2 Expansion joints

Expansion joints shall comply with the following:

- (a) *Box gutters* For box gutters and support systems, the maximum lengths between expansion joints and minimum expansion space shall be as given in Table 4.1. The gaps between the stop ends shall be bridged by a suitable saddle flashing. The maximum lengths between expansion joints in Table 4.1 shall apply from the fixed point to the free end/s.
- (b) *Eaves gutters* Eaves gutters shall have support systems that permit longitudinal thermal expansion without detriment to the gutter or accessories.
- (c) *Downpipes* Downpipes shall have support systems that permit thermal expansion without detriment to the downpipe or accessories.

NOTE: The temperature variation experienced by products will depend upon geographical location, extent of shading and absorptivity and surface colour. During summer, in most parts of Australia and New Zealand, the temperature of products exposed to direct sunlight may exceed 80°C.

4.4 CORROSION

4.4.1 Corrosion due to direct contact

Metal roof drainage system components, including accessories and fasteners, and, where applicable, metal cladding shall be designed with either—

- (a) compatible metals in direct contact (see Table 4.2); or
- (b) where unavoidable, incompatible metals separated by an impervious non-conducting material.

NOTES:

- 1 Combinations of metals, given in Table 4.2, are based on current knowledge and the premise that the area of rainwater goods or metal cladding is relatively large in comparison to that of accessories or fasteners.
- 2 The resistance of roof drainage system components of certain metals to corrosive agents is partly dependent on the beneficial washing action of rain and no permanent ponding.
- 3 The service life of most metals in severe marine atmospheres and industrial areas with atmospheres contaminated by acid-bearing agents can be extended by the use of special painting procedures (see AS/NZS 2312).

4.4.2 Corrosion due to drainage

Metal roof drainage system components shall be designed and installed to prevent corrosion, erosion, or both, due to drainage from metal and non-metal roof drainage system components and, where applicable, cladding.

NOTE: Table 4.3 gives guidance on combinations for materials to prevent corrosion, erosion, or both, due to drainage.

TABLE 4.1

BOX GUTTERS AND SUPPORT SYSTEMS—MAXIMUM LENGTH BETWEEN EXPANSION JOINTS AND MINIMUM EXPANSION SPACE

| Material | Coefficient of thermal expansion per °C | Base metal thickness mm | Maximum length between expansion joints m | | Minimum expansion space mm |
|-----------------|---|----------------------------|--|------------------------|-------------------------------|
| | | | One end fixed and one end free to move | Both ends free to move | |
| Aluminium | 24×10^{-6} | 0.90 | 12 | 24 | 50 |
| | | 1.00 | 12 | 24 | |
| Copper | 17×10^{-6} | 0.60 | 9 | 18 | 50 |
| | | 0.80 | 15 | 30 | |
| | | 1.00 | 26 | 52 | |
| Steel | 12×10^{-6} | 0.55 | 20 | 40 | 50 |
| | | 0.75 | 25 | 50 | |
| Stainless steel | 17×10^{-6} | 0.55 | 20 | 40 | 50 |
| PVC | 70×10^{-6} | — | 10 | 20 | 30 |
| Zinc | 26×10^{-6} | 0.80 | 10 | 20 | 50 |

4.4.3 Corrosion due to crevices

Metal roof drainage systems and support systems shall be designed and installed to achieve complete drainage or drying. Shielded areas capable of causing permanent ponding shall be avoided to prevent the possibility of intense localized corrosion known as crevice corrosion.

NOTE: This type of attack results from contact of metal with moisture and salts under oxygen-deficient conditions where trapped moisture cannot readily evaporate. It can be caused by lap joints, absorbent gaskets, holes, crevices under bolt or rivet heads or surface deposits including non-metallic materials, such as elastomeric materials, plastic, fabrics, lifted paint films or accumulated solids.

4.4.4 Corrosion dues to chemical incompatibility

Bedding materials used in conjunction with roof drainage systems shall be chemically compatible. Cement-based bedding may be used between tiles and valley gutters other than those of exposed aluminium/zinc alloy coated steel.

4.5 INSTALLATION AND TESTING

4.5.1 Installation

Installation of each new, or altered section of the roof drainage system shall be in compliance with the following:

- (a) There shall be no restrictions to the free flow of stormwater due to—
 - (i) protrusions or other obstructions; or
 - (ii) debris, e.g., cement, mortar, clippings, and similar.
- (b) All accessories shall be effectively fixed and securely anchored.

4.5.2 Testing

Downpipes within buildings shall comply with Section 10.

TABLE 4.2
COMPATIBILITY OF DIRECT CONTACT BETWEEN METALS

| Roof drainage system components and any cladding material | Accessory or fastener material | | | | | | | | | | | | Fastener material |
|---|--------------------------------|------|---------------------------|------|------------------------------|------|----------------------------|------|-----------------------------------|------|-----------|------|---------------------------|
| | Aluminium alloys | | Copper and copper alloys* | | Stainless steel (300 series) | | Zinc-coated steel and zinc | | Aluminium/zinc alloy-coated steel | | Lead | | Ceramic or organic coated |
| | Atmospheric classification | | | | | | | | | | | | |
| | SI and VS | Mild | SI and VS | Mild | SI and VS | Mild | SI and VS | Mild | SI and VS | Mild | SI and VS | Mild | SI, VS and Mild |
| Aluminium alloys | Yes | Yes | No | No | † | Yes | ‡ | ‡ | Yes | Yes | No | No | Yes |
| Copper and copper alloys | No | No | Yes | Yes | No | Yes | No | No | No | No | No | Yes | Yes |
| Stainless steel (300 series) | No | No | No | No | Yes | Yes | No | No | No | No | No | Yes | Yes |
| Zinc-coated steel and zinc | Yes | Yes | No | No | No | Yes | Yes | Yes | Yes | Yes | No | Yes | Yes |
| Aluminium/zinc alloy-coated steel | Yes | Yes | No | No | No | Yes | ‡ | ‡ | Yes | Yes | No | No | Yes |
| Lead § | No | No | Yes | Yes | Yes | Yes | No | Yes | No | No | Yes | Yes | Yes |

* Includes monel metal rivets.

† Grade 316 in accordance with ASTM A240 is suitable.

‡ Unpainted zinc-coated steel and zinc are suitable for direct contact but should not receive drainage from an inert catchment.

§ Due to its toxicity, lead is not recommended for rainwater goods.

LEGEND:

SI, VS, Mild = severe industrial, very severe and mild classifications (see AS/NZS 2312).

Yes = acceptable—as a result of bimetallic contact, either no additional corrosion of rainwater goods will take place, or at the worst, only very slight additional corrosion. It also implies that the degree of corrosion would not significantly shorten the service life.

No = not acceptable—moderate to severe corrosion of rainwater goods will occur, a condition which may result in a significant reduction in the service life.

NOTE: Unless adequate separation can be assured, prepainted rainwater goods should be considered in terms of the base metal or coated metal product.

TABLE 4.3
COMPATIBILITY OF DRAINAGE FROM AN UPPER SURFACE
TO A LOWER METAL SURFACE

| Lower roof drainage system material | Upper cladding or roof drainage system material | | | | | | | | | | |
|-------------------------------------|---|--------------------------|------------------------------|----------------------------|-----------------------------------|------|------------------|------------|----------|---------|-------|
| | Aluminium alloys | Copper and copper alloys | Stainless steel (300 series) | Zinc-coated steel and zinc | Aluminium/zinc alloy-coated steel | Lead | Prepainted metal | Roof tiles | | Plastic | Glass |
| | | | | | | | | Glazed | Unglazed | | |
| Aluminium alloys | Yes | No | * | Yes | Yes | * | Yes | Yes | Yes | Yes | Yes |
| Copper and copper alloys | * | Yes | * | * | * | Yes | * | Yes | Yes | Yes | Yes |
| Stainless steel (300 series) | * | * | Yes | * | * | Yes | * | Yes | Yes | Yes | Yes |
| Zinc-coated steel and zinc | No | No | No | Yes | No | * | No | No | Yes | No | No |
| Aluminium/zinc alloy-coated steel | Yes | No | * | Yes | Yes | No | Yes | Yes | Yes | Yes | Yes |
| Lead | * | * | * | * | * | Yes | * | Yes | Yes | Yes | Yes |

* Whilst drainage between the materials shown would be acceptable, direct material contact should be avoided (see Table 4.2).

LEGEND:

Yes = acceptable No = not acceptable

NOTE: 'Acceptable' and 'not acceptable' imply similar performances to those noted in Table 4.2.

4.6 INSPECTION AND CLEANING

NOTES:

- 1 Sizing of stormwater drainage installations assumes that the responsible owner or manager arranges regular inspection and cleaning to remove any obstructions that would reduce the installation's hydraulic capacity or design lifetime, or both.
- 2 Obstructions that could cause partial or complete reduction in the hydraulic capacity are windborne plastics, drink cans, builders' refuse, balls, bird nests, items deposited by birds, dead birds, leaves, moss, mortar, silt or similar.
- 3 Guards on gutters and gutter outlets and screens on outlets from on-site stormwater detention (OSD) facilities are installed to prevent reduction in hydraulic capacity due to obstructions. Installation of such guards and screens does not eliminate the need for regular inspection and cleaning. Guards used with rainwater goods might collect debris during high intensity storms, in spite of regular inspection and cleaning, and for this reason it might be better not to install such guards, particularly on box gutter sumps.

4.7 ALTERATIONS AND DISCONNECTION

NOTES:

- 1 Disused roof drainage system components, including overflow devices, should be removed and any resulting openings to the remaining roof drainage system or surface-drainage system should be sealed in a manner appropriate for the material remaining in use.
- 2 Disused accessories and fasteners should be removed and any damage to the building made good in a manner appropriate for the material damaged.

4.8 EAVES GUTTERS

Eaves gutters shall be installed as follows:

- (a) *Gradients* Deviations from nominal gradients shall be smooth and not cause permanent ponding.

NOTES

- 1 Where a building is likely to move due to reactive soils, gradients may need to be not flatter than—
 - (a) 1:250 to achieve an effective gradient not flatter than 1:500; or
 - (b) 1:500 to achieve an effective gradient with no permanent ponding.
 - 2 Light condensation will not generally cause permanent ponding whereas heavy condensation, particularly in conjunction with retained silt, can reduce the design lifetime of the product.
- (b) *Lap joints* For metal gutters with laps between 20 mm to 25 mm the lap shall be fully sealed. Wider laps shall be sealed and fastened at each end of the lap rather than filling the total area.
 - (c) *Support systems* Support systems shall comply with Clause 4.16.

4.9 BOX GUTTERS

Box gutters shall be installed as follows:

- (a) *Gradients* Gradients shall be not flatter than 1:200 for sole widths equal to or less than 600 mm wide. Deviations from these gradients shall be smooth and not cause permanent ponding.
- (b) *Lap joints* Lap joints shall be in accordance with Clause 4.8(b).
- (c) *Support systems* Support systems shall be in accordance with Clause 4.8(c).
- (d) *Outlets* Outlets shall discharge through either a rainhead or a sump.

- (e) *Expansion joints* Where necessary, expansion joints shall be provided (see Clause 4.3). All fixings shall be in the form of cleats and clips to allow freedom of movement.

NOTE: The sides of a box gutter should have adequate structural strength so that water pressure will not cause deformation that can affect water surface levels and hence the hydraulic capacity of a box gutter.

4.10 VALLEY GUTTERS

Valley gutters shall be installed as follows:

- (a) *Lap joints* Lap joints shall be in accordance with Clause 4.8(b) and 150 mm min. lap for an unsealed joint.
- (b) *Support systems* Support systems shall be in accordance with Clause 4.8(c).
- (c) *Edges* Edges shall be rolled or returned to prevent splashing.

4.11 DOWNPIPES

Downpipes shall be installed as follows:

- (a) *Locations* Downpipes shall be located—
- (i) so that they do not interfere with the normal operation of any door, window, access opening or occupancy of a building;
 - (ii) where they do not cause a nuisance or lead to injury of a person;
 - (iii) as close as practicable to the supporting structure;
 - (iv) so that they are adequately protected from mechanical damage;
 - (v) at least 100 mm clear of any electrical cable or gas pipe; and
 - (vi) at least 50 mm from any other pipework or service.
- (b) *Concealment or limited access* Downpipes in buildings may be concealed or have limited access provided—
- (i) the inspection openings (see Item (d)) are accessible;
NOTE: To facilitate maintenance, inspection openings should be extended to the face of a wall or slab.
 - (ii) the installation complies with the manufacturer's recommended installation and maintenance procedures for the materials and products;
 - (iii) the seams and joints are watertight; and
 - (iv) unless otherwise directed by an engineer, they are—
 - (A) clear of any structural member, e.g., beam, or column, or party wall; or
 - (B) not concealed in any dry wall construction that could interfere with the structural integrity of the wall.
- (c) *Connections within buildings* Where a downpipe is connected to a site stormwater drain located below a slab-on-ground, the connection shall be located above the level of the floor.
- (d) *Inspection openings* Inspection openings for testing and maintenance purposes shall have a nominal size of not less than nominal diameter of the downpipe.
- (e) *Support systems* The support systems shall comply with Clause 4.16.

4.12 OVERFLOW DEVICES OR MEASURES

Overflow devices for box gutters shall comply with Clause 3.7.5. Overflow measures for eaves gutters shall comply with Clause 3.5.3.

4.13 JOINTS FOR METAL COMPONENTS

4.13.1 General

Compatibility of materials shall be in accordance with the requirements of Table 4.2 and Table 4.3.

4.13.2 Type of joints

4.13.2.1 Soldered

Soldered joints shall be clean and free from grease, and shall be flush and lapped in the direction of the outlets, as specified, and completely sweated with solder to form a secure joint that does not cause permanent ponding. Immediately after cleaning, the surfaces to be jointed shall be painted with the appropriate flux given in Table 4.5.

NOTES:

- 1 60/40 or 80/20 tin/lead solder can enhance the surface finish of stainless steel.
- 2 Because of the risk to health and safety, care should be exercised during the preparation and handling of fluxes.

The laps for—

- (a) eaves gutters, shall be—
 - (i) for in-line joints, not less than 25 mm; and
 - (ii) for all other joints, as specified by the manufacturer; and
- (b) box gutters fasteners shall be spaced at not more than 40 mm centres and not less than 10 mm from the edges of the joint.

4.13.2.2 Sealant

Sealant joints shall be used in conjunction with mechanical connections or fasteners as specified in AS/NZS 2179.1, spaced at not more than 40 mm centres. The sealant shall be sandwiched between clean surfaces of the components of the joint to ensure a positive seal and to protect the sealant from exposure to ultraviolet radiation. To ensure complete cure of silicone rubber sealants, the width of sealant bead, when compressed, should not exceed 25 mm.

Laps shall be as for soldered joints, as appropriate.

TABLE 4.5
FLUXES

| Material to be joined | Type of flux |
|-------------------------|---|
| Zinc-coated steel | Dilute hydrochloric acid* |
| Copper and copper alloy | Zinc chloride (killed spirits) |
| Stainless steel | Phosphoric acid based flux for soldering† |
| Zinc | Zinc chloride (killed spirits) |

* Muriatic acid, 1:3 dilution of hydrochloric acid.

† Chloride-based fluxes are not used.

4.13.3 Aluminium alloys

Aluminium alloy components including accessories shall be jointed with one of the following:

- (a) *Brazed joints* Brazed joints shall have a minimum lap and shall be brazed with aluminium/silicon alloys containing $11.5 \pm 1.5\%$ silicon. Lower melting point aluminium/silicon alloys shall not be used. Flux-affected areas shall be thoroughly washed with water to prevent subsequent corrosion.
- (b) *Welded joints* Welded joints shall be shop fabricated and be either the gas metal-arc welding (GMAW) or gas tungsten-arc welding GTAW type (see AS 1665).
- (c) *Soldered joints* Soldered joints shall not be used with aluminium alloys due, in the presence of moisture, to galvanic action.

NOTES:

- 1 Field fabrication should be limited to joints that are fully protected from air movement and moisture.
- 2 GMAW and GTAW types are also known as MIG and TIG welding types, respectively.

4.13.4 Aluminium/zinc alloy-coated steel

Aluminium/zinc alloy-coated steel components, including accessories, shall be jointed with sealant joints and fasteners as specified in Clause 4.13.1.2.

4.13.5 Stainless steel

Stainless steel components including accessories shall be jointed with one of the following:

- (a) *Sealant joints* Sealant joints shall be as specified in Clause 4.13.1.2.
- (b) *Soldered joints* Soldered joints shall be as specified in Clause 4.13.1.1.
- (c) *Welded joints* Welded joints shall be either—
 - (i) spot welds at normal rivet centres, i.e., about 40 mm, and sealed with either solder by sweating from the inside or sealant; or
 - (ii) continuous weld.

Where material thickness allows, GMAW or GTAW may be used.

4.13.6 Zinc and zinc-coated steel

Zinc and zinc-coated steel components, including accessories, shall be jointed with one of the following:

- (a) *Sealant joints* Sealant joints shall be as specified in Clause 4.13.1.2.
- (b) *Soldered joints* Soldered joints shall be as specified in Clause 4.13.1.1.

4.14 JOINTS FOR PVC COMPONENTS

Joints for PVC components, including accessories, shall comply with AS/NZS 2179.2(Int).

4.15 JOINTS FOR OTHER COMPONENTS

Joints for other components of similar and dissimilar metals and non-metals shall be as given in Table 4.6.

TABLE 4.6
PERMISSIBLE JOINTS FOR OTHER COMPONENTS OF SIMILAR OR
DISSIMILAR MATERIALS

| To material 2 | From material 1 | | | | | | | | |
|----------------------------------|--------------------|-----------|-------------------------------------|----------------------------------|----------------------|----------------|----------------|------------------------------------|-------------------------|
| | Aluminium alloy | | Cast iron and ductile iron | Copper and copper alloy | Galvanized steel | FRC* | GRP | PVC | PE |
| Aluminium alloys | BG ES ER | MC WD† | BG ES | — | BG ES ER | — | — | BG ES SC/ER | — |
| Cast iron and ductile iron | BG ES | — | BG ES ER | BG SB/ER | BG ER | BG ES ER | BG ES ER | BG ES SC/ER | — |
| Copper and copper alloy | — | — | BG ER/SB | SB ES SS | BG TH/SB ER/SB | BG ER | BG ES | SC/TH/ SB SC/ER/ SB ES | BF/TH TH/TH TH/SS |
| Galvanized steel | BG ES | — | BG ER | SB/TH SB/ER | TH BG MC | ER | BG ER | SC/TH SC/ER | — |
| FRC* | — | — | BG ES ER | BG ER | ER | BG ES ER | — | ES ER | — |
| GRP | — | — | — | — | — | BG ES ER | BG ER ES | — | — |
| PVC | BG ES | — | BG ES ER/SC | SB/TH/SC SB/ER/SC ES | TH/SC ER/SC | BG ES ER | — | SC ES FC | SC/TH |
| PE | BG ES | — | — | TH/BF TH/TH SS/TH | — | — | — | TH/SC | BF TH EF ES MC FL |

* Under buildings limited to ES.

† Limited to shop GTAW for thicknesses equal to or greater than 0.7 mm.

| LEGEND | | | | | |
|---------------|-----------------------------------|-----------|--------|---------------------|-----------|
| Symbol | Joint type | Reference | Symbol | Joint type | Reference |
| BF | Butt fusion | | MC | Mechanical coupling | AS 1761 |
| BG | Bolted gland | 2.8.2.1 | SB | Silver brazed | 2.8.2.8 |
| EF | Electrofusion | | SC | Solvent cement | 2.8.2.10 |
| ER | Epoxy resin | 2.8.2.4 | SS | Soft solder | 2.8.2.9 |
| ES | Elastomeric seal | 2.8.2.3 | TH | Threaded | 2.8.2.11 |
| FC | Metal-bonded flexible coupling | 2.8.2.6 | WD | GMAW or GTAW | AS 1665 |
| FL | Flanged | AS 4087 | | | |

NOTES:

- 1 The direction of flow is to be from material 1 to material 2.
- 2 Where joint types are separated by one or more slashes, the joint between pipe materials requires an appropriate transition fitting or adaptor.
- 3 Joints of dissimilar materials shall comply with Clause 4.4.

4.16 SUPPORT SYSTEMS

4.16.1 Types

The types of support systems are either non-trafficable or trafficable (see vertical load test of AS/NZS 2179.1) and may be discontinuous or continuous.

4.16.2 Criteria

Support systems shall—

- (a) be fabricated from materials that—
 - (i) are compatible with the supported roof drainage system; and
 - (ii) where exposed to direct sunlight, are resistant to ultraviolet light;
NOTE: Incompatible materials may be used provided the contact surfaces are lined with a non-abrasive, impervious, non-conducting material.
- (b) be securely attached to the building structure;
- (c) have no other service attached to them or be attached to any other service;
- (d) be protected against corrosion where exposed to a corrosive environment; and
- (e) be securely attached to prevent longitudinal movement, unless designed to allow for thermal effect.

4.16.3 Support systems for eaves gutters

Support systems for eaves gutters manufactured from—

- (a) metals shall comply with AS/NZS 2179.1;
- (b) PVC shall comply with AS/NZS 2179.2(Int); and

all eaves gutters and their support systems shall be non-trafficable.

4.16.4 Support systems for box gutters

Support systems for box gutters manufactured from—

- (a) metals shall comply with AS/NZS 2179.1; and
- (b) PVC shall comply with AS/NZS 2179.2(Int).

Such support systems shall be either—

- (i) continuous, where the support extends across the sole width for the full length of the gutter and provides a direct evenly distributed contact to not less than 25% of the sole width; or
- (ii) discontinuous, where the support brackets extend across the sole width of the gutter and are located at stop ends, both ends of sumps, rainheads and intervals not greater than 750 mm, or are located in accordance with manufacturers instructions.

NOTES:

- 1 Continuous support systems should be used for sole widths greater than 450 mm.
- 2 For the design loads for support systems (see AS/NZS 1170.1).

4.16.5 Support systems for valley gutters

Support systems for valley gutters manufactured from—

- (a) metals shall comply with AS/NZS 2179.1; and
- (b) PVC shall comply with AS/NZS 2179.2(Int).

NOTE: For the design loads for support systems refer to AS/NZS 1170.

4.16.6 Support systems for downpipes

4.16.6.1 Vertical

Support systems for vertical downpipes manufactured from—

- (a) metals shall comply with AS/NZS 2179.1; and
- (b) PVC shall comply with AS/NZS 2179.2(Int).

4.16.6.2 Graded

Support systems for graded downpipes of—

- (a) metals shall comply with AS/NZS 2179.1; and
- (b) PVC shall comply with AS/NZS 2179.2(Int).

Jointed pipes and fittings shall have support spacing—

- (i) for aluminium alloys, not exceeding 2000 mm;
- (ii) for cast iron, ductile cast iron, copper, copper alloys, galvanized steel and stainless steel, not exceeding 3000 mm;
- (iii) for FRC and GRP, not exceeding 4000 mm;
- (iv) for PVC, as specified for pressure pipe systems in AS 2032; and
- (v) for PE, as specified for pressure pipes above ground in AS 2033.

SECTION 5 SURFACE DRAINAGE SYSTEMS — DESIGN

5.1 SCOPE OF SECTION

This Section specifies methods for the design and procedures for surface drainage systems.

5.2 DESIGN METHODS

5.2.1 Methods

This Section provides two design methods, as follows:

- (a) The general method (see Clause 5.4)
- (b) The nominal method (see Clause 5.5).

Either method may be used within the specified limitations.

5.2.2 General criteria

Piped systems shall meet the minimum pipe diameter, cover and gradient criteria specified in this Standard. Such systems shall be arranged so that any overflows will not pond against, or enter into buildings.

5.2.3 Design rainfall intensity

Elements shall be designed to contain within surface drains, gutters or formed flow paths minor storm events of the appropriate average recurrence interval (ARI) specified in Table 5.1. Surface drainage systems shall be designed to ensure overflows, in storm events with an ARI of 100 years in Australia or 50 years in New Zealand, do not present a hazard to people or cause significant damage to property.

5.3 LAYOUT

5.3.1 General

Layouts of surface drainage systems should take full advantage of the existing and proposed topography of the site and the position and level of the point or points of connection to the stormwater drainage network.

5.3.2 Influences on layout

Factors that determine a layout include the following:

- (a) Site conditions, including—
 - (i) the intended uses of existing and proposed buildings;
 - (ii) location of downpipes and overflow devices, where appropriate, surcharge outlets and outlets of any internal drainage or pump-out systems;
 - (iii) any stormwater discharges from adjacent land;
 - (iv) location of existing and proposed pervious and impervious areas, such as paved areas, parking lots and gardens;
 - (v) soil types and strata, and vegetative cover and trees;
 - (vi) locations of access to the site, and to ground-level and below-ground floors of buildings (see Clause 5.3.3.4);
 - (vii) location of existing and proposed services, e.g., sanitary drains, water services and similar;

- (viii) works necessary to protect buildings and other services during the installation of the surface water drainage system;
 - (ix) works necessary to protect the surface water drainage system during the construction of proposed buildings and other services;
 - (x) location of special drainage facilities, such as on-site stormwater detention storage areas and tanks; and
 - (xi) location of existing and proposed arresters to reduce contaminants, e.g., petroleum products, leachate from rubbish tips on industrial or commercial sites.
- (b) Provision for overland flow paths for the safe disposal of stormwater flows due to discharge from—
- (i) roof drainage system overflow devices due to blockages of downpipes;
 - (ii) surcharged site stormwater drains or point(s) of connection, i.e., surcharge outlets or inlet pits; or
 - (iii) rainfall events with an ARI greater than the design ARI, allowing for possible discharges from adjacent areas.

5.3.3 General criteria for layouts

5.3.3.1 Roof areas

Stormwater from roof areas shall, in general, be collected and conveyed in gutters and downpipes (see Section 3) and, during periods of high rainfall intensity or blockage of the roof drainage system, be discharged through overflow devices—

- (a) to site stormwater drains or channels;
- (b) to paved areas; or
- (c) to—
 - (i) impinge onto concrete or stone splash blocks and then infiltrate into pervious areas; or
 - (ii) discharge to subsoil drains or soakaways, either directly, i.e., by pipe, or indirectly, i.e., by infiltration.

NOTE: Such systems may be desirable in areas with permeable soils, as a means of reducing the discharge of stormwater or increasing the water table; however, in areas with impervious soils, such systems may cause waterlogging of land and dampness in buildings. Where soils are expansive, damage may occur to footings. Consequently, all proposals for these systems may be required to be authorized by the regulatory authority.

5.3.3.2 Other than roof areas

Stormwater from other than roof areas shall, in general, be collected and conveyed via site stormwater channels and inlets to site stormwater drains.

5.3.3.3 Ponding

Except for on-site stormwater detention (OSD) systems (see Clause 5.4.13), ponding of stormwater shall only occur temporarily at sag pits complying with Clause 5.4.10.1.

NOTES:

- 1 Where the ground floor of a building is lower than the adjacent land, except at access ramps, the latter should be graded so that there is a reverse slope away from the building to permit the discharge of stormwater to a site stormwater drain or channel.
- 2 The ground beneath timber floors and landscaping around and under buildings should be graded to prevent ponding and permit drainage to the outside of buildings.

5.3.3.4 *Entry into buildings*

Stormwater shall be prevented from entering doorways and other openings in buildings. Where these are lower than adjacent ground surfaces, grated drains shall be designed and placed across ramps or entrances to intercept any flow, which would otherwise drain into the building.

5.3.3.5 *Containment of harmful substances*

Separate surface drainage systems or special arresters (see Clause 8.6) shall be provided for any parts of the property where materials that could pollute or block such drainage systems are stored or used. These drainage systems shall comply with the criteria of the network utility operator regarding containment of polluting substances.

5.3.3.6 *Inlet and pit locations*

Inlet pits should be located to intercept surface flows, while also fitting neatly into the layout of the site stormwater drains.

On-grade pits situated on sloping surfaces or in channels or gutters shall be sized to intercept a large proportion of the flow. They shall be located so that any bypass flows under minor storm event conditions will not cause a nuisance and that widths of concentrated flow are negotiable by pedestrians.

Inlet pits in locations subject to dengue fever borne by mosquitoes shall be without a sump and be self-draining.

NOTES:

- 1 Care should be taken in locating and specifying details of grated pits in areas subject to pedestrian or vehicular traffic to avoid possible damage to pits and danger to pedestrians and cyclists.
- 2 Site stormwater drains should be laid in straight lines—
 - (a) to avoid conflict with other services; and
 - (b) to minimize overall length and number of changes in direction.

5.3.3.7 *Sanitary drainage system*

Surface drainage systems shall be completely separate to any sanitary drainage system.

5.4 GENERAL METHOD

5.4.1 Basis

The general method may be used for all buildings.

Surface drainage systems shall be designed to provide protection against potential losses caused by any overflows, including damage to buildings and their contents, and injury and nuisance to persons.

NOTES:

- 1 The general method for design of surface drainage systems uses the Rational Formula (see Equation 5.4.8) to calculate design flows from rainfalls of a given ARI and hydraulic charts to determine characteristics of the pipes needed to convey such flows. As consequences of failure may vary at different locations on a property, the ARI can be increased to reflect this.
- 2 The larger the ARI selected for design, the greater the design rainfall intensity and flow, the larger the system and, subject to regular inspection and cleaning (see Clause 4.6), the lower the probability of overflow.
- 3 Examples that illustrate the application of the general methods are given in Appendix K.

5.4.2 Overland flood path

Where consequences of failure of a surface drainage system are significant, allowance shall be made for flows on to the site from adjacent properties. The system shall convey flows without serious consequences such as entry of water into openings in buildings. If this does occur, remedial action shall be taken, such as one or more of the following:

- (a) Enlargement or extension of the surface drainage system.
- (b) Alteration of surfaces and flow paths by regrading and redirection, or provision of landscaping, bunds and other barriers.
- (c) Raising the level of the lowest floor.

5.4.3 ARI

Appropriate values of ARI for design vary according to the importance of the property, consequences of failure and local practice.

The ARI shall be as given in Table 5.1.

TABLE 5.1
AVERAGE RECURRENCE INTERVALS

| Effect of surcharge—Overland flow | ARI*, years | |
|--|-------------|-------------|
| | Australia | New Zealand |
| Small impact, in low density areas | ≥1 | ≥1 |
| Normal impacts | ≥2 | ≥2 |
| Ponding in flat topography; or flooding of parking lots to depths greater than 150 mm | ≥10 | ≥10 |
| Impeded access to commercial and industrial buildings | ≥10 | ≥10 |
| Ponding against adjoining buildings; or impeded access to institutional or important buildings (e.g., hospitals, town halls, school entrances) | ≥20 | ≥10 |

* A higher ARI is appropriate where there is only limited access for maintenance.

NOTE: For Australia Table 5.1 should be used in conjunction with the BCA which has requirements to prevent rain and stormwater from entering certain buildings.

5.4.4 Time of concentration

The time of concentration used in the general method for design of surface drainage systems shall be as follows:

- (a) Australia 5 min.
- (b) New Zealand 10 min.

5.4.5 Rainfall intensity

The rainfall intensity used in Equation 5.4.8 is determined for a duration equal to the time of concentration and the selected ARI using design information available—

- (a) in Australia from—
 - (i) the network utility operator, design aids showing rainfall intensities for various durations and ARIs;
 - (ii) Appendix E, which shows rainfall intensities for 5 min duration and ARIs of 20 and 100 years; or
 - (iii) ARR87; and

- (b) in New Zealand from—
- (i) the network utility operator, design aids showing rainfall intensities for various durations and ARIs; or
 - (ii) Appendix F, which shows rainfall intensities for 10 min duration and ARIs of 10 and 50 years.

NOTE: Design aids are usually in the form of rainfall intensity/frequency duration plots and tables supplied—

- (a) in Australia by the Hydrometeorological Advisory Services of the Bureau of Meteorology (see Appendix D); or
- (b) in New Zealand by the National Institute for Water and Atmosphere (see Appendix D).

5.4.6 Run-off coefficients

The run-off coefficients used in Equation 5.4.8 shall be as follows:

- (a) In Australia, they shall have the following values:
 - (i) For a roofed area, C_r equal to 1.0.
 - (ii) For an unroofed impervious (paved) area, C_i equal to 0.9.
 - (iii) For an unroofed pervious area—
 - (A) as calculated from the following equation:

$$C_p = m(0.0133^{10} I_{60} - 0.233) \quad \dots 5.4.6$$

where

- C_p = run-off coefficient, for an unroofed pervious area
 m = factor dependent on the selected ARI (see Table 5.2)
 $^{10}I_{60}$ = Rainfall intensity for a 60-min (1 h) duration and ARI of 10 years, in millimetres per hour but if—
- (a) less than 25, adopt 25; or
 - (b) greater than 70, adopt 70

for—

- (1) clay soils, increase C_p by 0.1; and
- (2) sandy soils, decrease C_p by 0.1, provided that the final value of C_p is not less than 0.1; or

- (B) as nominated by the network utility operator.

- (b) In New Zealand, they shall have the following values:
 - (i) For a roofed area C_r for—
 - (A) steel and non-absorbent surfaces equal to 0.9; and
 - (B) near flat and slightly absorbent, equal to 0.8.
 - (ii) For an unroofed impervious (paved) area, C_i for ground slopes of 1:20 to 1:10 with—
 - (A) asphalt and concrete surfaces, equal to 0.85; and
 - (B) store, brick and precast paving panels and—
 - (1) sealed joints, equal to 0.8; and
 - (2) open joints, equal to 0.60.

- (iii) For an unroofed pervious area, C_p for ground slopes of 1:20 to 1:10, as given Table 5.3.

For ground slopes other than 1:20 to 1:10, the values given in Items (ii) and (iii) shall be varied in accordance with Table 5.4.

TABLE 5.2
MULTIPLIERS FOR RUN-OFF COEFFICIENTS

| ARI Years | m |
|------------------|------|
| 1 | 0.8 |
| 2 | 0.85 |
| 5 | 0.95 |
| 10 | 1.0 |
| 20 | 1.05 |
| 50 | 1.15 |
| 100 | 1.2 |
| greater than 100 | 1.25 |

Source: ARR87 (except for ARIs longer than 100 years).

TABLE 5.3
RUN-OFF COEFFICIENTS (C_p)—NEW ZEALAND

| Description of surface | Value for C_p | Description of surface | Value for C_p |
|---|----------------------|--|-----------------|
| Natural surface types Bare impermeable clay with no interception channels or run-off control | 0.70 | Developed surface types Unsealed roads | 0.50 |
| Bare uncultivated soil of medium soakage | 0.60 | Railway and unsealed yards and similar surfaces | 0.35 |
| Heavy clay soil types: —pasture and grass cover —bush and scrub cover —cultivated | 0.40 0.35 0.30 | Land use types Fully roofed or sealed developments | 0.90 |
| Medium soakage soil types: —pasture and scrub cover —bush and scrub cover —cultivated | 0.30 0.25 0.20 | Industrial, commercial, shopping areas and town house developments | 0.65 |
| High soakage gravel, sandy and volcanic soil types: —pasture and grass cover —bush and scrub cover —cultivated | 0.20 0.15 0.10 | Residential areas in which impervious area exceeds 35% of gross area. (This includes most modern subdivisions) | 0.45 |
| Parks, playgrounds and reserves: —mainly grassed —predominantly bush | 0.30 0.25 | | |
| Gardens and lawns. | 0.25 | | |

5.4.7 Catchment area

The catchment area used in Equation 5.4.8 for the components of surface drainage systems shall be the plan area of the catchment, including buildings, draining to a particular component.

For minor storm events the catchment area is limited to the extent of the property. For major storm events the catchment area may extend beyond the property (see Clause 5.4.2).

TABLE 5.4
ADJUSTMENT FOR GROUND SLOPE—NEW ZEALAND

| Ground slope | Adjustment to values of C_i and C_p |
|-------------------|---|
| Flatter than 1:20 | -0.05 |
| 1:20 to 1:10 | Nil |
| 1:10 to 1:5 | +0.05 |
| Steeper than 1:5 | +0.10 |

5.4.8 Determination of design flows

The general method for the determination of design flows shall be as follows:

- (a) Select from Table 5.1 the ARI for the particular application.
- (b) Determine from Clause 5.4.5 for the particular location the rainfall intensity, in millimetres per hour, for the selected ARI and—
 - (i) 5 mins duration in Australia; or

- (ii) in New Zealand, a duration of—
 - (A) 5 min, for commercial and industrial developments;
 - (B) 7 to 10 min, for residential developments; or
 - (C) 10 min, for low density residential developments.
- (c) Determine by physical observations and dimensions or from the relevant plans, or both—
 - (i) the layout for—
 - (A) the downpipes (see Clause 3.7.4(c)); and
 - (B) the site stormwater drains, including the available gradients and appurtenances (see Section 8);
 - (ii) the limits of the sub-catchments for the components of the surface water drainage systems; and
 - (iii) for each sub-catchment—
 - (A) the run-off coefficients based on the extent and type of surface (see Clause 5.4.6); and
 - (B) the plan areas of roofed, impervious and pervious surfaces, in square metres.
- (d) Determine the design flow for appropriate sub-catchments of the surface water drainage system from the following equation:

$$Q = \frac{(C_r A_r + C_i A_i + C_p A_p) {}^Y I_t}{3600} \text{ or } \frac{\Sigma CA {}^Y I_t}{3600} \quad \dots 5.4.8$$

where

- Q = design flow of stormwater, in litres per second
- C_r = run-off coefficient for a roofed area
- A_r = total roofed catchment area, in square metres
- C_i = run-off coefficient for an unroofed impervious (paved) area
- A_i = total unroofed impervious (paved) catchment area, in square metres
- C_p = run-off coefficient for an unroofed pervious area
- A_p = total unroofed pervious catchment area, in square metres
- ${}^Y I_t$ = rainfall intensity for a duration of t and an ARI of Y , in millimetres per hour
- ΣCA = equivalent impervious area of all upstream areas on the property, in square metres

NOTE: No allowance is included for flow from subsoil drains.

5.4.9 Design of open channels

The general method for designing an open channel for a site stormwater drain shall be as follows:

- (a) Determine the design flow, in accordance with Clause 5.4.8.
- (b) Determine by physical observation and dimensions or from the relevant plans, or both, the gradient of the open channel.

- (c) Select a surface type and Manning roughness coefficient (see Table 5.5) and dimensions for the open channel, then calculate its hydraulic capacity from the following equation (Manning):

$$Q_c = 1000 \frac{A}{n} R^{2/3} S^{1/2} \quad \dots 5.4.9$$

where

- Q_c = hydraulic capacity of open channel, in litres per second
 A = cross-sectional area of flow in open channel, in square metres
 R = hydraulic radius, in metres
 S = gradient of open channel
 n = Manning roughness coefficient for an open channel
- (d) If the hydraulic capacity (see Step (c)) is less than the design flow (see Step (a)), assume a new set of dimensions for the open channel and repeat Step (c) until the hydraulic capacity exceeds the design flow.
- (e) Check that the depth of flow in the channel is at least 300 mm below the floor level or damp course of any adjacent building. If the water level is higher than this limit, the channel shall be enlarged or its bed lowered to meet this requirement.

TABLE 5.5
MANNING ROUGHNESS COEFFICIENT (n)

| Surface type | Typical values for n |
|------------------------------------|------------------------|
| Polyethylene (PE) | 0.009 to 0.010 |
| Polyvinylchloride (PVC) | 0.009 to 0.010 |
| Smooth concrete | 0.011 to 0.012 |
| Trowelled concrete | 0.012 to 0.015 |
| Asphalt paving | 0.013 to 0.015 |
| Brickwork | 0.014 to 0.016 |
| Roughly jointed bricks or pitchers | 0.016 to 0.020 |
| Sprayed concrete (gunite) | 0.016 to 0.020 |
| Earth-lined channels | 0.018 to 0.025 |
| Corrugated metal | 0.012 to 0.015 |
| Rock lining or rip-rap | 0.025 to 0.030 |
| Rock cut | 0.035 to 0.040 |
| Grassed or vegetated channels | 0.025 to 0.075* |

* Depending on vegetation growth

5.4.10 Design of inlets

5.4.10.1 Sag pits

The general method for designing an inlet for a sag pit shall be as follows:

- (a) Determine the design flow in accordance with Clause 5.4.8.
- (b) Determine by observations or relevant plans the maximum depth of ponding, noting where water may pond against, or enter, a building then the maximum level, unless otherwise authorized by the network utility operator, shall be not less than 300 mm below the floor or damp course of the building.

- (c) Calculate the capacity of an inlet, if the depth of ponding is—
 (i) equal to or less than 0.12 m, from the following equation:

$$Q_i = b_f 1600 P d_p^{1.5} \quad \dots 5.4.10.1$$

where

Q_i = capacity of an inlet for a sag pit, in litres per second

b_f = blockage factor, inlets to stormwater pits

P = wetted perimeter of an open channel, in metres

d_p = depth of ponding over inlet, in metres

- (ii) or greater than 0.12 m, from street drainage manuals (see the Section on pipe system drainage in ARR87).

NOTE: A common value for b_f is 0.5.

5.4.10.2 On-grade pits

Inlet capacities of on-grade pits vary considerably with the shape and size of pit. Blockage factors are variable, but a value of 0.8 (reducing capacities to 80% of values given by design aids) shall be used for on-grade pits if no other information is available from the network utility operator.

NOTE: Reference should be made to street drainage design manuals, manufacturer's literature and the recommendations.

5.4.11 Design of pipe drains

5.4.11.1 General

Pipe drains of site stormwater drains shall—

- (a) be laid with even gradients and straight runs and with a minimum number of changes of direction or change of cross-section, consistent with having adequate hydraulic capacity;
- (b) be laid with any change of direction or cross-section occurring at either an appropriate fitting or at a pit;
- (c) be constructed of materials and products, as specified in Clause 2.5;
- (d) have pits and arresters, as specified in Clause 8.6;
- (e) have surcharge outlets, as specified in Clause 5.4.12; and
- (f) have jump-ups, as specified in Clause 8.9.

5.4.11.2 Design procedure

The general method for designing a pipe drain for a site stormwater drain shall be as follows:

- (a) Determine the design flow, in accordance with Clause 5.4.8.
- (b) Determine by physical observation and dimensions or from the relevant plans, or both, a suitable gradient for the pipe drain.
- (c) Select the pipe material and the Colebrook-White roughness coefficient from AS 2200, or see Table 5.6 for normal conditions, and determine from Figure 5.1 the hydraulic capacity of the pipe drain for the selected DN.

- (d) If the hydraulic capacity is less than the design flow, assume a new DN for the pipe drain and repeat Step (c) until the hydraulic capacity exceeds the design flow. To reduce the possibility of overflow from stormwater pits due to increased energy losses, the full-pipe velocity in the outlet pipe is recommended not to exceed 1.5 m/s and shall not exceed 2.0 m/s.

TABLE 5.6
COLEBROOK-WHITE ROUGHNESS COEFFICIENT (*k*)

| Pipe material | Typical values for <i>k</i> , mm |
|--|----------------------------------|
| Copper, copper alloys, stainless steel | 0.015 |
| All plastic pipelines having a smooth (non-profiled) internal bore | 0.015 |
| Fibre-reinforced concrete (FRC) | 0.15 |
| Cast iron, ductile iron, galvanized steel and malleable cast iron | 0.6 |
| Vitrified clay, precast concrete | 0.6 |
| Corrugated aluminium and steel | 3.0 |

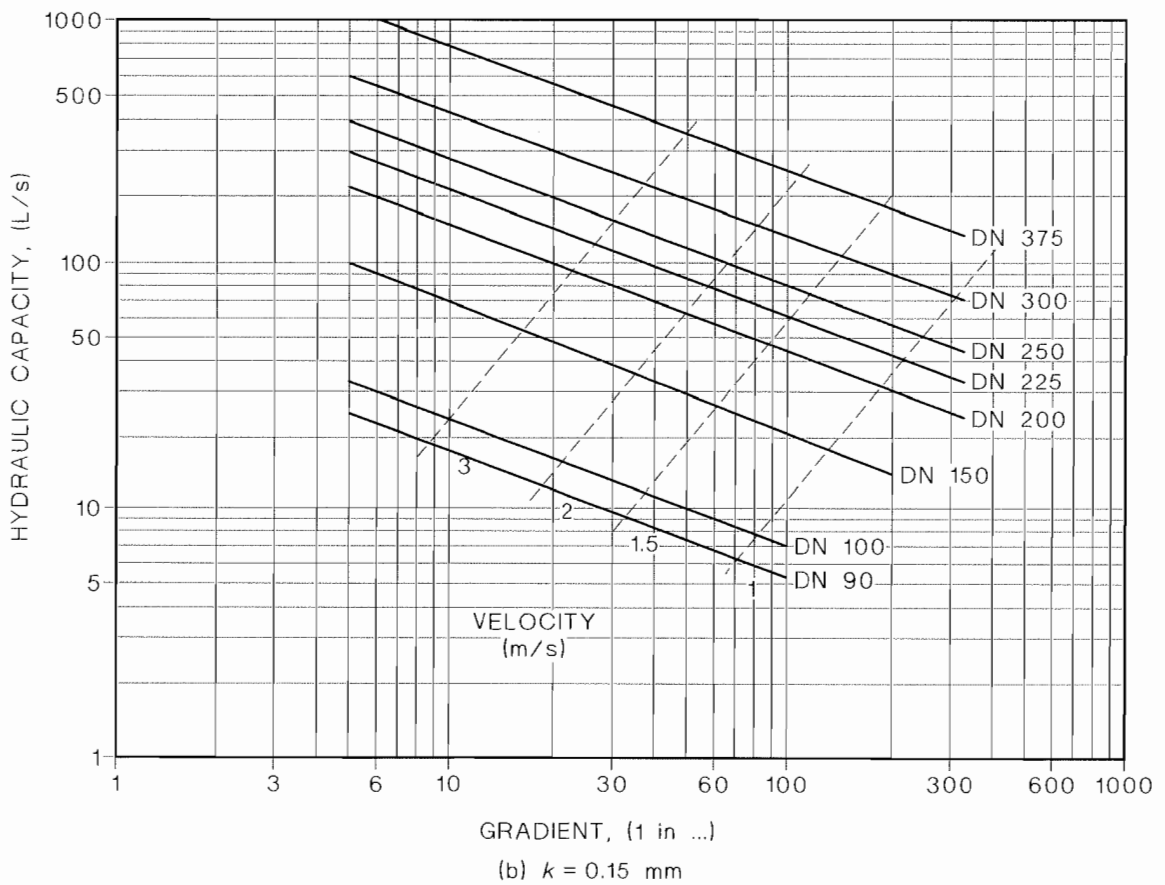
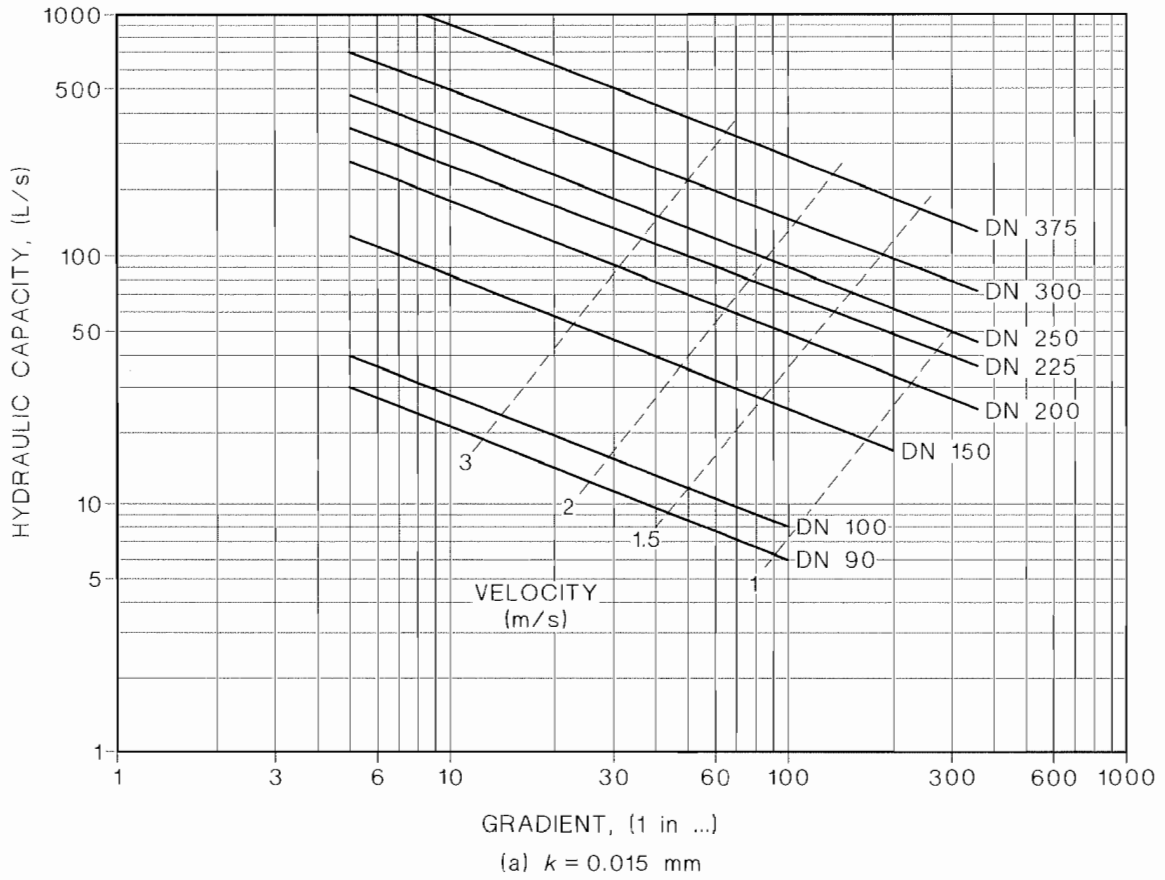

FIGURE 5.1 (in part) HYDRAULIC DESIGN CHARTS—WATER AT 20°C

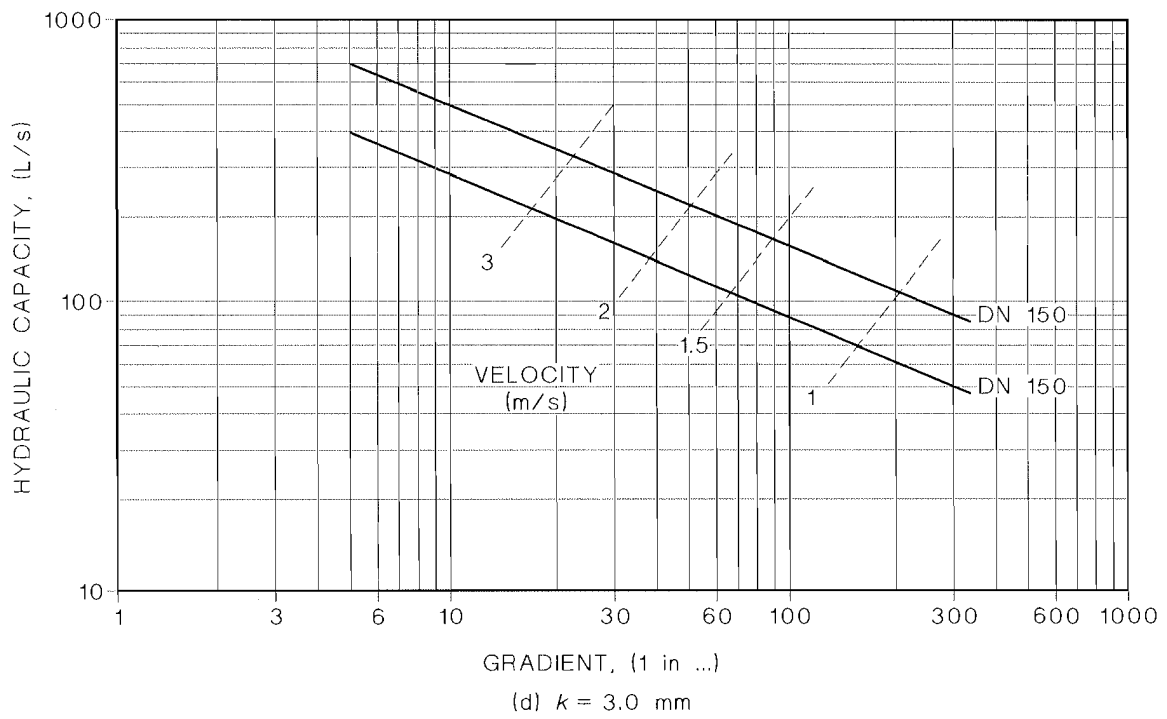
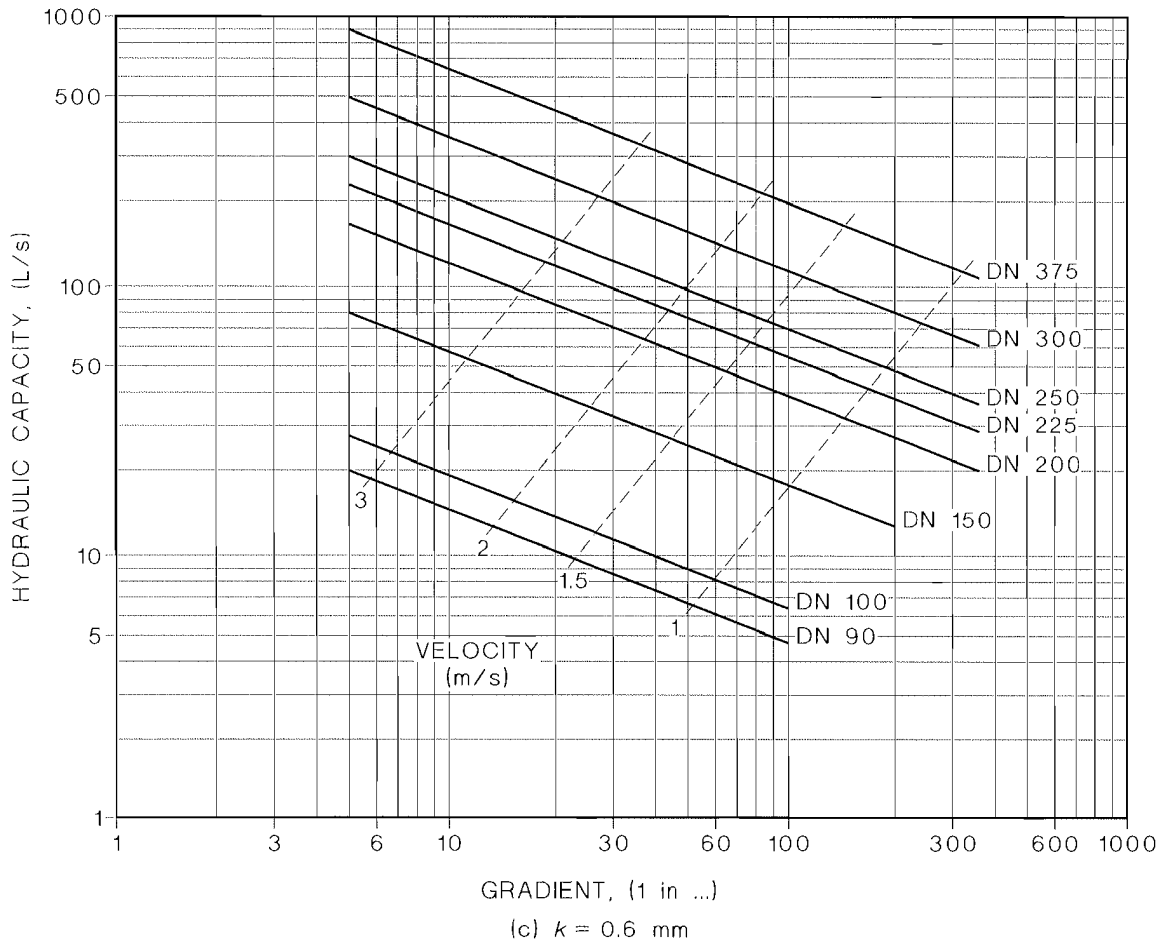

FIGURE 5.1 (in part) HYDRAULIC DESIGN CHARTS—WATER AT 20°C

5.4.12 Design of surcharge outlets

5.4.12.1 General

Where the connection of any downpipes to the surface drainage system is not open to the atmosphere and where a surcharge outlet will not affect the normal operation of the system, at least one surcharge outlet shall be located along the site stormwater drain leading to a point of connection. This surcharge outlet may also operate as an inlet pit or a grated drain.

Surcharge outlets shall be located—

- (a) with the grate level—
 - (i) unless otherwise authorized by the network utility operator, not less than 300 mm below the lowest floor level; and
 - (ii) not less than 75 mm above an unpaved surface or level with a paved finished surface;
- (b) wholly within the property;
- (c) clear of any buildings;
- (d) so that any discharge is noticeable; and
- (e) with an overflow path, so that overflows will not cause damage to buildings (including contents) or danger to persons.

5.4.12.2 Design procedure

The procedure of the general method for design of a surcharge outlet shall be as follows:

- (a) Determine the minimum area of the grated opening from the following equation:

$$A = \frac{Q}{150} \quad \dots 5.4.12.2$$

where

A = the minimum grated area, in square metres

Q = the design flow of stormwater (assuming full blockage), in litres per second

- (b) Determine the exit velocity from the grated outlet and if greater than 0.15 m/s increase the area of grate to achieve the determined exit velocity.

5.4.13 On-site stormwater detention (OSD) system

NOTE: A solution is not available for design of OSD systems because of sufficient data is not available.

5.4.14 Concentrated discharges to streets

Where the network utility operator places a limit on the discharges that can be made to a street gutter at a single point, the surface drainage system shall be altered if it is found that the discharge exceeds such a limit. Alterations would usually involve the division of a pipe system into two or more systems, discharging independently to the street (see Clause 8.6.1.2(b)).

5.4.15 Snowfall effects

NOTE: In regions subject to snowfalls there is no special effect on the sizes of elements of surface drainage systems, but precautions should be taken to minimize the entry of stormwater run-off or meltwater into buildings or ponding against buildings as a result of accumulated snow.

5.5 NOMINAL METHOD

The 'nominal method' may be used for single dwellings in non-urban areas, and single dwellings on urban allotments with less than 1000 m² in area. Pipe design shall be determined according to local practice and experience (without specific design calculations), and according to the minimum diameter (Clause 7.3.4), cover (Clause 7.2.6), gradient (Clause 7.4.6) and other relevant criteria of this Standard.

The layout shall comply with Clause 5.3.

NOTES:

- 1 An example illustrating the application of the nominal method is given in Appendix K.
- 2 This method is suitable for two dwellings one above the other.

SECTION 6 SUBSOIL DRAINAGE SYSTEMS — DESIGN

NOTES:

- 1 A method of design is outlined in Appendix M.
- 2 Detailed design of subsoil drainage systems are complex and dependent on particular site or soil conditions. Such systems should be undertaken with advice from a suitably qualified competent person. An example of a suitable qualified competent person is a professional engineer specializing in geotechnical engineering.

SECTION 7 SURFACE AND SUBSOIL DRAINAGE SYSTEMS — INSTALLATION

7.1 SCOPE OF SECTION

This Section specifies installation requirements for site stormwater drains for conveyance of stormwater from roof and surface (see Clause 7.2, as applicable, and Clause 7.3), and subsoil drainage systems (see Clause 7.2, as applicable, and Clause 7.4).

7.2 GENERAL REQUIREMENTS

7.2.1 Products and joints

Products and joints for site stormwater drains and subsoil drains shall comply with Section 2 and Clause 4.15.

7.2.2 Erosion and sediment controls

During construction appropriate precautions to minimize soil erosion and the escape of sediment from the site due to rainfall and stormwater should be considered. These precautions may include—

- (a) covering exposed or disturbed surfaces with vegetation or meshes to prevent erosion and mobilization of sediments;
- (b) surface grading of sites and the direction of stormwater flow paths through construction sites so that erosion is minimized, including limits on slopes and lengthening of flow paths using barriers;
- (c) provision of sediment barriers along flow paths and watercourses, such as silt fences, hay bales and porous stone filters; and
- (d) construction of temporary sediment traps or basins (usually near site boundaries) to collect sediments for removal.

7.2.3 Terminology

Trench terminology for flexible and rigid pipes is shown in Figure 7.1.

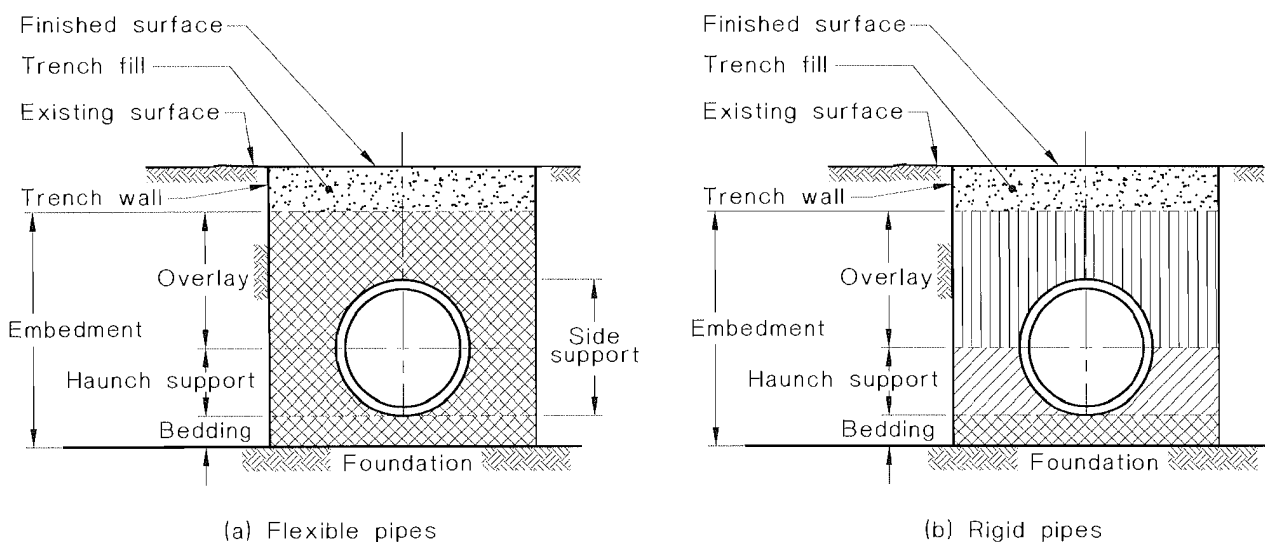

FIGURE 7.1 TRENCH TERMINOLOGY

7.2.4 Trench width

Trench widths measured at the top of the pipes, between the faces of either the unsupported trench walls or the inside face of the sheeting of the trench support system, shall be not less than the widths specified in—

- (a) AS 1762, for corrugated metal pipes;
- (b) AS/NZS 2566.1, for flexible pipes and fittings;
- (c) AS 3725, for FRC and reinforced concrete pipes; and
- (d) AS 4060, for vitrified clay and ceramic pipes and fittings.

7.2.5 Over-excavation

Where a trench has been excavated deeper than necessary, the excess depth shall be filled either with bedding material compacted to achieve a density as near to the original soil density as possible, or with concrete.

7.2.6 Cover

Except as specified in Clause 7.3.7, the cover shall be not less than that given in Table 7.1 or shall be in accordance with—

- (a) AS 1762, for corrugated metal pipes;
- (b) AS 2032, for PVC pipes;
- (c) AS/NZS 2566.1, for flexible pipes and fittings;
- (d) AS 3725, for reinforced concrete and FRC pipes;
- (e) AS 4060, for vitrified clay and ceramic pipes and fittings; and
- (f) AS 2033, for polyethylene pipes

7.2.7 Proximity to other services

Above and below ground site stormwater drains shall be installed as follows:

NOTE: The proximity to other services will vary, depending on the type and size of the services affected.

- (a) No potential safety hazard shall be created when in close proximity to other services.
- (b) Access for maintenance and potential branch insertions shall not be impaired by other services.
- (c) Sites shall not be located where physical damage to the drain is likely to occur, unless adequate protection is provided.
- (d) Separation from above-ground electrical conduit, wire, cable, consumer gas pipes or water service shall be at least 100 mm between any downpipe.
- (e) Stormwater drains shall not be installed in below ground situations where electrical supply cables, consumer gas piping, water service or communications cable are intended to be installed below ground in the area above the drain.
- (f) The separation between any underground stormwater drain and an electrical supply cable shall be at least—
 - (i) 100 mm provided the electrical supply cable is indicated along its length with orange marker tape complying with AS/NZS 2648.1 and is mechanically protected; or
 - (ii) 600 mm where the electrical supply cable is neither indicated nor mechanically protected.

- (g) The separation between any underground stormwater drain and consumer gas pipes shall be at least—
- (i) 100 mm provided the consumer gas pipe is indicated along its length with marker tape complying with AS/NZS 2648.1 laid 150 mm above the installed pipe; or
 - (ii) 600 mm where the consumer gas pipe is neither indicated nor mechanically protected.
- NOTE: Mechanical protection is provided by concrete slabs, continuous concrete pour, or bricks designed for protecting electrical supply cables.
- (h) The separation between any underground stormwater drain and an electrical earthing electrode, for an electrical supply not exceeding 1000 V, shall be at least 600 mm. For an electrical supply exceeding 1000 V, the relevant regulatory authority shall be contacted for a ruling.
- (i) The separation between any underground drain and a communication cable shall be at least 100 mm.
- (j) The separation between any underground stormwater drain and any other service other than consumer gas piping and electrical or communication service shall be at least—
- (i) 100 mm from a drain not exceeding DN 100 and is serving the same property; and
 - (ii) 300 mm for any other service exceeding DN 100.
- (k) Any underground stormwater drain crossing another service shall—
- (i) cross at an angle of not less than 45° (see Figure 7.2);
 - (ii) have a vertical separation of not less than 100 mm; and
 - (iii) be marked along its length for 1 m either side of the centreline of the service with marker tape complying with AS/NZS 2648.1, laid 150 mm above the installed service.

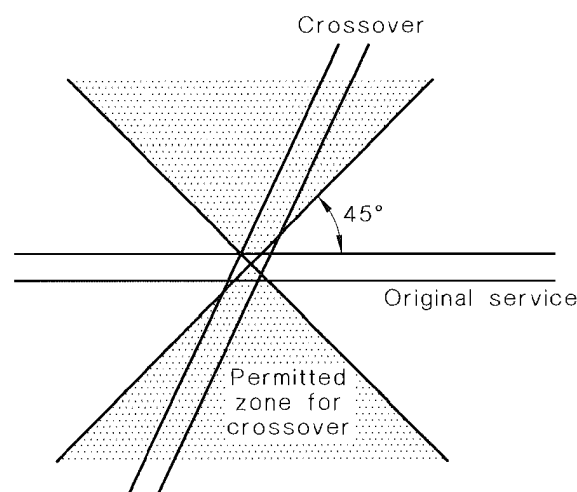

FIGURE 7.2 PERMITTED CROSSOVER ZONE FOR ELECTRICAL CABLES AND GAS PIPES

- (l) Stormwater drains shall be installed with sufficient clearance to any underground obstruction to protect the drain from physical damage and to permit repairs. The clearance shall be at least 300 mm.

NOTE: See Clause 7.2.9 for drains in close proximity to footings or foundations.

TABLE 7.1
MINIMUM PIPE COVER
(from finished surface to top of pipe)

| Location | millimetres | |
|--|--|-------------------------------|
| | Cast iron, ductile iron, galvanized steel | Other authorized* products |
| Minimum cover | | |
| 1 Not subject to vehicular loading: | | |
| (a) without pavement— | | |
| (i) for single dwellings | Nil | 100 |
| (ii) for other than Item (i) | Nil | 300 |
| (b) with pavement of brick or unreinforced concrete | Nil† | 50† |
| 2 Subject to vehicular loading: | | |
| (a) other than roads— | | |
| (i) without pavement | 300 | 450 |
| (ii) with pavement of— | | |
| (A) reinforced concrete for heavy vehicular loading | Nil‡ | 100‡ |
| (B) brick or unreinforced concrete for light vehicular loading | Nil‡ | 75‡ |
| (b) roads— | | |
| (i) sealed | 300 | 500‡ |
| (ii) unsealed | 300 | 500‡ |
| 3 Subject to construction equipment loading or in embankment conditions | 300 | 500‡ |

* Includes overlay above the top of the pipe of not less than 50 mm thick.

† Below the underside of the pavement.

‡ Subject to compliance with AS 1762, AS 2033, AS/NZS 2566.1, AS 3725 or AS 4060.

7.2.8 Shoring and underpinning buildings

Where the bottom of the trench is adjacent to or below the footing and walls of any adjoining building or structure, the footing shall be adequately supported while the trench is open.

NOTE: Criteria for the footing support and backfilling of the trench should be determined by a professional engineer.

7.2.9 Installation near and under buildings

A drain in close proximity to footings or foundations shall comply with the following:

- (a) Where the drain passes under a strip footing, its angle of intersection with the footing in the horizontal plane shall not be less than 45°, and the minimum clearance between the top of the drain to the underside of the footing shall be 25 mm.
- (b) If the drain is laid through footings or walls, other than below ground, external walls, it shall be installed with an annular space of not less than 25 mm filled with a liner of flexible material.

- (c) The drain may be laid through below ground external walls, provided that—
 - (i) two flexible joints are provided externally within 800 mm of the external face of the wall, and such joints are not less than 600 mm apart; and
 - (ii) the penetration of the wall is made watertight.
- (d) Where the drain is to be laid parallel to a footing, the trench shall be located—
 - (i) in Australia—
 - (A) in accordance with the Housing Provisions of the BCA Clause 3.1.2.2(d);
 - (B) for single dwellings, as shown in Figure 7.3; and
 - (C) for all others, as determined by a suitably qualified competent person; or
 - (ii) in New Zealand, as specified in E1/AS1.
- (e) Criteria for pile systems shall be determined by a suitable qualified competent person.

A2

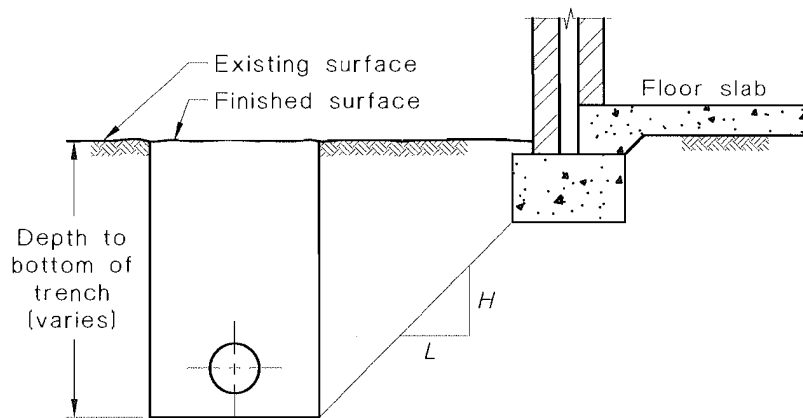

| Soil type | Slope H:L | |
|-----------------|----------------|--------------------|
| | Compacted fill | Undisturbed ground |
| Stable rock (*) | 2:3 | 8:1 |
| Sand (*) | 1:2 | 1:2 |
| Silt (†) | 1:4 | 1:4 |
| Firm clay | 1:2 | 1:1 |
| Soft clay | Not suitable | 2:3 |
| Soft soils (†) | Not suitable | Not suitable |

* Most sand and rock sites with little or no ground movement from moisture changes.

† Sites include soft soils, such as soft clay or silt or loose sands; landslip; mine subsidence; collapsing soils; soils subject to erosion; reactive sites subject to abnormal moisture conditions or sites which cannot be classified otherwise.

NOTE: This Table has been adapted from the BCA Housing Provisions and users of this Standard should satisfy themselves that the Table is still relevant and has not been amended.

FIGURE 7.3 EXCAVATION NEAR FOOTINGS

7.2.10 Water-charged ground

Excavation in water-charged ground shall be in accordance with the following:

- (a) The water level shall be lowered below the bottom of the proposed trench and maintained at that level during construction, including the placing of trench fill.
- (b) Dewatering shall be carried out by pumps and spearheads or similar devices. The removed water shall discharge to a location where it shall not cause a nuisance or damage, and in no case shall it discharge, either directly or indirectly, into any sanitary sewer.

NOTE: Where water-charged ground is encountered, consideration needs to be given to the effect on adjacent buildings and other services.

7.2.11 Other than stable grounds

Unless otherwise authorized by the network utility operator, where excessive soil movement due to filled, unstable or water-charged ground may affect the performance of any site stormwater drain or subsoil drain, then such drain shall be installed in accordance with the plans and specification, based on a geotechnical report and calculations, prepared by a suitably qualified competent person.

NOTE: In proclaimed mine subsidence districts, site stormwater drains larger than DN 225 should comply with the requirements of the relevant authority.

7.2.12 Trench fill

Trench fill shall either—

- (a) be material excavated from the trench or imported, provided that the material placed within 300 mm of the top of pipes is free from builders' waste, bricks, pieces of concrete, rocks or similar material that would be retained on a 75 mm sieve; or
- (b) be embedment material (see Clause 7.3.6).

7.2.13 Backfilling

Trench fill shall be placed in loose layers not more than 200 mm thick and compacted to not less than 90% or 95% under pavements of the standard maximum dry density specified in AS 1289.5.4.1 or AS 1289.E6.1, in such a way that the pipes are neither dislodged nor damaged.

The finished surface (top of trench fill) and the trench surround shall be restored, as near as practicable, to the level and condition of the existing surface before commencement of the excavation (see Figure 7.1).

7.2.14 Excavation near point of connection

Excavation by a machine shall not be carried out within 600 mm of a point of connection to an external stormwater drainage network.

7.3 SITE STORMWATER DRAINS

7.3.1 Corrosive areas

Buried metal pipes and fittings in corrosive areas shall be externally protected by—

- (a) an external protective coating (see Clause 2.13.4);
- (b) sealed polyethylene sleeving (see Clause 2.13.7); or
- (c) continuous wrapping with petrolatum taping material.

NOTE: Corrosive areas contain compounds consisting of magnesium oxychloride (magnesite) or its equivalent, coal wash, sodium chloride (salt), ammonia or materials that may be detrimental to the installation.

7.3.2 General

7.3.2.1 Site stormwater drains

- (a) Site stormwater drains shall be laid—
- (i) with no lipped joints or internal projections;
 - (ii) so as to prevent the ingress of embedment and trench fill, or embankment fill;
 - (iii) with protection, as required, to prevent damage during installation and service; and
 - (iv) using sweep junctions.

7.3.2.2 Site stormwater pipes

Pipes for site stormwater drains shall—

- (a) have joints that comply, where appropriate, with Clauses 2.8 and 4.15;
- (b) where installed below ground, for other than cast iron, ductile iron and galvanized steel, be continuously supported by embedment (see Clause 7.3.6);
- (c) where installed above ground, have support systems authorized by the network utility operator; and
- (d) be cleaned internally prior to installation and commissioning.

7.3.3 Connections to pits and arresters

Where a site stormwater drain passes through the wall of a pit or arrester that is more than 1 m deep, two flexible joints shall be located on such drain within 800 mm of the outer face of the structure, and not more than 600 mm apart.

7.3.4 Minimum diameter

Minimum diameters—

- (a) for single dwellings in rural areas, and residential buildings on urban allotments with areas less than 1000 m², shall be DN 90; and
- (b) for other properties, downstream of a stormwater or inlet pit, shall be the greater of—
 - (i) the diameter of the largest pipe entering the pit; or
 - (ii) DN 150.

An exception to this is at footpath crossings (see Clause 8.6.1.2(b)) where multiple pipes of DN 100 or less may be used.

7.3.5 Gradients

The minimum gradient of a site stormwater drain shall be as given in Table 7.2. No maximum gradient is specified, but designers should be aware of the possibility of scour of pipes by rapid flows, particularly by sediment-laden water.

TABLE 7.2
MINIMUM GRADIENT OF SITE STORMWATER DRAINS

| Nominal size | Minimum gradient | | Nominal size | Minimum gradient | |
|--------------|------------------|-------|--------------|------------------|-------|
| | Aust. | NZ | | Aust. | NZ |
| DN 90 | 1:100 | 1:90 | DN 225 | 1:200 | 1:350 |
| 100 | 1:100 | 1:120 | 300 | 1:250 | 1:350 |
| 150 | 1:100 | 1:200 | 375 | 1:300 | 1:350 |

7.3.6 Embedment

7.3.6.1 Materials

Embedment material shall comply with the following:

- (a) Pipes shall be as specified in—
 - (i) AS 1762, for corrugated metal pipes;
 - (ii) AS 2032, for PVC pipes;
 - (iii) AS 2033, for polyethylene pipes;
 - (iv) AS/NZS 2566.1, for flexible pipes and fittings;
 - (v) AS 3725, for FRC and reinforced concrete pipes; and
 - (vi) AS 4060, for vitrified clay and ceramic pipes and fittings; and
- (b) All other authorized pipe materials:
 - (i) Bedding material shall be—
 - (A) suitable sand, free from rock or other hard or sharp objects that would be retained on a 13.2 mm sieve;
 - (B) crushed rock or gravel up to a maximum size of 14 mm;
 - (C) excavated material, provided that this is free from rock or hard matter, and is broken up so that it contains no soil lumps having any dimension greater than 75 mm; or
 - (D) cement mortar containing one part of portland cement and four parts of sand by volume thoroughly mixed with clean water to a workable consistency.
 - (ii) Side support and overlay material shall comply with Item (b)(i), (A), (B), or (C).

7.3.6.2 Installation

Embedment shall be installed so that a site stormwater drain is neither dislodged nor damaged, and in accordance with the following:

- (a) AS 1762, for corrugated metal pipes.
- (b) AS 2032, for PVC pipes.
- (c) AS/NZS 2566.1, for flexible pipes and fittings.
- (d) AS 3725, for FRC and reinforced concrete pipes.
- (e) AS 4060, for vitrified clay and ceramic pipes and fittings.
- (f) All other authorized materials shall be as follows:
 - (i) The pipe class shall comply with Section 2.
 - (ii) The foundation shall be consistent and excavated to the gradient and, where over excavated, shall comply with Clause 7.2.5.
 - (iii) The bedding material shall be one of the following:
 - (A) Cement mortar, as specified in Clause 7.3.6.1 (b)(i)(D), where the trench foundation is rock or shale and the gradient is steeper than 1:5 and shall—
 - (1) be a minimum depth of 50 mm measured below the bottom of the pipe;

- (2) be not less than 75 mm wide;
 - (3) be kept clear of flexible joints; and
 - (4) have pipes supported at distances not greater than 1.5 m from the centres of support, prior to placing the mortar bedding; or
- (B) Earth foundations not less than 75 mm thick.
- (C) Rock foundations not less than 100 mm thick with the haunch support not less than 75 mm thick (see Figure 7.1).
- NOTE: Cast iron and ductile iron pipes may be unsupported for up to 600 mm either side of each pipe joint.
- (iv) Chases shall be excavated in the bedding and, if necessary, in the foundation to prevent sockets bearing on either, while pipe lengths shall be fully supported within 600 mm of each socket.
 - (v) The embedment material specified in Clause 7.3.6.1(b)(i) Items (A) to (C) shall be placed in loose layers not more than 200 mm thick and compacted to 90% of the standard maximum dry density as specified in AS 1289.5.4.1 or AS 1289.E6.1.

7.3.7 Cover under buildings

For site stormwater drains under buildings—

- (a) the thickness of overlay between the top of the pipe and the underside of a reinforced concrete slab shall be not less than 25 mm; and
- (b) there shall be adequate protection from mechanical damage.

7.3.8 In easements and public places

7.3.8.1 General requirements

A site stormwater drain located in a road, easement, public place, right of way or the like in an open-cut trench, shall be installed in accordance with the following:

- (a) Where the full depth at the point of connection is not required to drain the property, a jump-up (see Clause 8.9) shall be installed either at the point of connection, or within the property boundary.
- (b) Where the presence of any conduit or pit prevents the site stormwater drain from being laid at an even grade with the required cover, then wherever practicable the drain shall pass beneath the conduit or pit at an even grade with a jump-up permitted only at the point of connection. If this is not practicable—
 - (i) an inclined section of pipe may be installed adjacent to the conduit or pit, in the form of a graded jump-up with changes of direction not greater than 60° in the vertical plane; and
 - (ii) there shall be a minimum clearance of 25 mm between the conduit or pit and the drain.
- (c) The site stormwater drain shall have a minimum cover as specified in Clause 7.2.6.
- (d) A site stormwater drain, located in a public road or right-of-way shall have no fitting, which is part of a stormwater drainage system, installed above the level of a finished surface.

7.3.9 Disconnection

Where a disused site stormwater drain is to be disconnected, the following criteria apply:

- (a) Where the disconnection is in water-charged ground, dewatering shall be carried out in accordance with Clause 7.2.10.
- (b) Disconnection shall be made at either the point of connection to the external stormwater drainage network or the connection to the works remaining.
- (c) Extraneous water, soil, sand, rock or other substances shall not be permitted to enter the site stormwater drain or external stormwater drainage network downstream of the disconnected section.
- (d) Site stormwater drains shall be made watertight using a cap or plug, and sealed in a manner appropriate to the material remaining in use.

7.3.10 Testing

Site stormwater drains, drains within and under buildings and main internal drains shall comply with Section 10.

7.4 SUBSOIL DRAINS

7.4.1 General

Subsoil drains shall be laid—

- (a) so any pipe or geocomposite drain employed can be flushed out;
- (b) with protection to prevent damage; and
- (c) with clean-out points for pipes or geocomposite drains—
 - (i) located at—
 - (A) their topmost ends (or heads); and
 - (B) each change of direction greater than 70°; and
 - (ii) constructed so that they—
 - (A) intersect the drain at an angle not greater than 45°;
 - (B) extend vertically to the top of paved surfaces or within 300 mm of an unpaved finished surface; and
 - (C) terminate with a screw cap legibly marked 'SW'.

Any pipes and fittings in such drains shall be—

- (1) cleaned internally prior to installation and commissioning;
- (2) continuously supported by embedment (see Clause 7.3.6); and
- (3) appropriately jointed where applicable.

NOTES:

- 1 Installation of subsoil drains may include—
 - (a) wrapping of the pipes or geocomposite drains with geotextile material prior to placement of the embedment;
 - (b) wrapping of all or part of the embedment with geotextile material; or
 - (c) other methods authorized by the regulatory authority.
- 2 Joint overlaps for geotextile material should not be less than 300 mm.

7.4.2 Embedment

7.4.2.1 Materials

The material for bedding, haunch support, side support and overlay is determined by—

- (a) the characteristics of the ground in which the subsoil drain is located;

- (b) the type of geotextile material used (if applicable).

Where the conduit consists of a pipe, the embedment material shall be crushed hard rock or natural gravel with not less than 90% by mass retained on a 9.5 mm sieve. Where the conduit is a geocomposite drain the material may be a coarse washed sand.

Criteria for sizing and determining arrangements of filter material are as follows:

- (i) For proper performance, the filter material (or backfill) shall surround the drain, under as well as over; however, this will depend on the nature of the strata being drained and the depth of drain.

If a drain penetrates a water-bearing layer, and is socketed into an impervious zone below, then the filter material shall as a minimum be placed in contact with the pervious soil. A suitable pipe bedding material may surround the pipe.

If a drain only partially penetrates a pervious layer such that water would be expected to flow into a drain over its entire depth, then the filter material shall surround the pipe and also to act as the pipe bedding material.

- (ii) Where pipe bedding is a different material to the filter material, it shall be coarser grained than the filter material and its particles have to be greater in size than the perforations in the pipe unless a geotextile wrapping is provided. Ideally, the grain size distribution of the bedding material should be chosen so that it itself acts as a filter to the filter zone.

NOTE: Common practice is to choose a free-draining, stable and inert material with a larger grain size than the filter, such as good quality, screened, crushed rock.

- (iii) A coarse washed sand should be used as a backfill when geocomposite subsurface drains are used. The coarse sand acts as the primary filter and the geotextile wrap on the drain as a secondary filter.

7.4.2.2 Installation

Subsoil drains shall be laid—

- (a) with embedment installed so that a subsoil drain is neither dislodged nor damaged; and
- (b) so as to prevent the ingress of embedment and trench fill.

7.4.2.3 Disconnection

Disused subsoil drains shall be disconnected in accordance with the following:

- (a) A subsoil drain shall only be disconnected if it has been established that it is not in use or that it is no longer required to serve its intended purpose.

NOTE: Where there is any doubt as to its purpose or the effects of disconnection, expert geotechnical advice should be sought.

- (b) A disconnection shall be made at a pit or other connection to a site stormwater drain.
- (c) Extraneous water, soil, sand, rock or other substances shall not be permitted to enter the site stormwater drain or external stormwater drainage system downstream of the disconnected section.

SECTION 8 SURFACE AND SUBSOIL DRAINAGE SYSTEMS — ANCILLARIES

8.1 SCOPE OF SECTION

This Section specifies criteria for ancillaries of surface and subsoil drainage systems.

8.2 PAVED SURFACES

Gradients for paved surfaces with areas exceeding 200 m², which form part of a surface drainage system in accordance with Clause 5.2.1(a), (b) or (c), are given in Table 8.1.

TABLE 8.1
TYPICAL GRADIENT LIMITS FOR PAVED AREAS

| Drained area | Gradient | | |
|---|--------------------------|--------------------------|------------------------|
| | Access roads | Paved areas | Footpaths |
| Longitudinal gradient or fall | 1:10 max.* | — | — |
| Road crossfall or average camber | 1:40 normal | 1:60 min. | 1:30 max. 1:40 min. |
| Kerb channels: (without concrete gutter) (with concrete gutter or high-class surfacing) | 1:150 min. 1:200 min. | 1:150 min. 1:200 min. | — — |
| Superelevation for road curves not exceeding 100 m radius | 1:25 max. | — | — |

* The first 10 m of an access road from its junction with a major road or public highway should have a gradient of not more than 1:30.

NOTE: Except for longitudinal gradient or fall, the typical gradient limits are taken from BS 6367.

8.3 POINT(S) OF CONNECTION

NOTE: See Clause 1.7.1 for criteria.

8.4 REFLUX VALVES

8.4.1 Purpose

Reflux or non-return valves allow flow in one direction only, permitting stormwater to flow from a property but preventing backflows due to surcharging of the downstream stormwater drainage network.

8.4.2 Location

Reflux valves and reflux valve chambers shall be located—

- (a) wholly within the property; and
- (b) in a stormwater pit unless such valve is—
 - (i) above the finished surface level and can be maintained from this level; or
 - (ii) within a building and accessible with clear space above so that it may be maintained.

8.4.3 Criteria

A reflux valve shall be installed—

- (a) where the network utility operator has determined a surcharge level at a gravitational point of connection that is above—
 - (i) any floor or basement level; or
 - (ii) if appropriate, any paved or unpaved area; or
- (b) where the surcharge outlet is omitted.

8.5 INSPECTION OPENINGS

8.5.1 Location

For other than single dwellings, inspection openings for the maintenance of site stormwater drains shall be extended to and capped at the finished surface level and be installed at—

- (a) each point of connection;
- (b) even spacings not more than 30 m apart;
- (c) each end of any inclined jump-up that exceeds 6 m in length;
- (d) each connection to an existing site stormwater drain; and
- (e) at any change of direction greater than 45°.

Inspection openings may be replaced by an inlet or stormwater pit.

8.5.2 Size

The nominal size of inspection openings for site stormwater drains shall be—

- (a) for nominal pipe sizes less than or equal to DN 150, the same size as the site stormwater drain; and
- (b) for nominal pipe sizes greater than DN 150, not less than DN 150.

8.5.3 Access

Access to below-ground inspection openings shall be either by—

- (a) a stormwater pit; or
- (b) a sealed riser terminated at ground level or floor level in an accessible position.

8.5.4 Plugs or caps

Inspection openings and unused sockets shall be sealed with airtight removable plugs or caps fitted with an elastomeric seal and securely held in position by a clip, strap or threaded connection. Each plug or cap shall be legibly marked 'SW'.

When a plug or cap with an elastomeric seal is removed, a new seal shall be fitted before it is replaced.

8.6 STORMWATER PITS, INLET PITS AND ARRESTERS

8.6.1 Purpose

8.6.1.1 Stormwater pits

Stormwater pits are installed—

- (a) to provide access to and, where appropriate, maintenance of—
 - (i) junctions, changes of gradient and changes of direction of site stormwater drains;

- (ii) inspection openings within buildings;
 - (iii) reflux valves; or
 - (iv) flap valves fitted at the downstream ends of subsoil drains; and
- (b) where appropriate, to operate as an inlet pit.

8.6.1.2 Inlet pits

Inlet pits are installed —

- (a) to permit the collection and ingress of stormwater to a site stormwater drain.
- (b) where necessary, to operate as a surcharge outlet (see Clause 5.4.12); or
- (c) when the point of connection is a street kerb and gutter and the diameter of the site stormwater drain is larger than DN 100.

NOTE: A sump and screen similar to that shown in Figure 8.1 should be provided adjacent to the property boundary to provide transition to smaller pipes or conduits passing under the footpath.

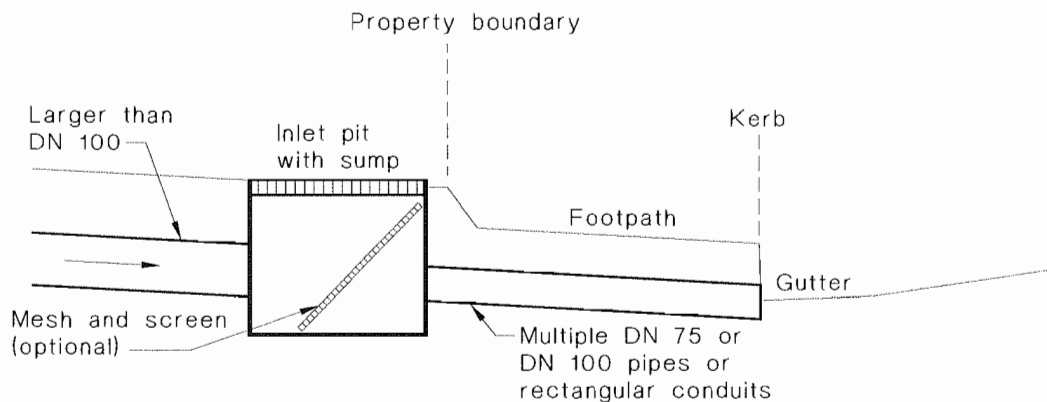

FIGURE 8.1 TYPICAL ARRANGEMENT OF INLET PIT AND FOOTPATH CROSSING

8.6.1.3 Arresters

Arresters shall be installed to remove contamination, generally silt, oil, or both, from stormwater prior to discharge to the stormwater drainage network.

8.6.2 Size

8.6.2.1 Stormwater and inlet pits

Minimum internal dimensions for stormwater and inlet pits are given in Table 8.2.

TABLE 8.2
MINIMUM INTERNAL DIMENSIONS FOR
STORMWATER AND INLET PITS

| Depth to invert of outlet | Minimum internal dimensions mm | | |
|------------------------------|-----------------------------------|--------|----------|
| | Rectangular | | Circular |
| | Width | Length | Diameter |
| ≤600 | 450 | 450 | 600 |
| >600 ≤900 | 600 | 600 | 900 |
| >900 ≤1200 | 600 | 900 | 1 000 |
| > 1 200 | 900 | 900 | 1 000 |

8.6.2.2 Arresters

The minimum internal dimensions and spacings for baffles and weirs for—

- (a) silt arresters shall be as shown in Figure 8.2; and
- (b) general purpose (oil or silt, or both) arresters shall be as shown in Figure 8.3.

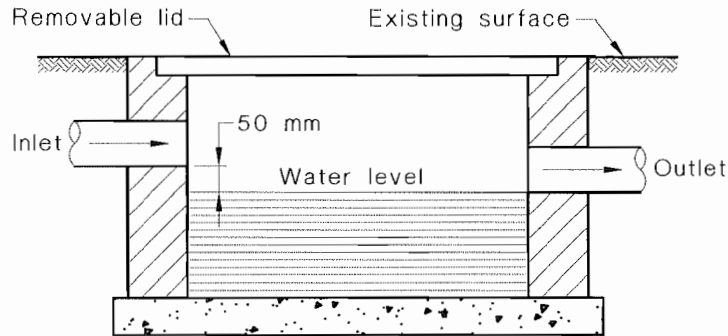

millimetres

| Nominal size of outlet DN | Minimum internal dimensions | | | |
|---------------------------|-----------------------------|--------|----------|------------------------------|
| | Rectangular | | Circular | Depth below invert of outlet |
| | Width | Length | Diameter | |
| ≤150 | 600 | 1 000 | 1000 | 450 |
| 225 | 700 | 1 000 | 1000 | 450 |
| 300 | 800 | 1 000 | 1000 | 450 |
| 375 | 1 000 | 1 200 | 1200 | 550 |

FIGURE 8.2 MINIMUM INTERNAL DIMENSIONS FOR SILT ARRESTERS

8.6.3 Falls across pits

The positions of inlet and outlet pipes for pits in site stormwater drains shall be selected to minimize head losses, and to facilitate the flushing of sediment from pits. The following criteria apply:

- (a) Where possible, inlet pipes shall be pointed directly at the pit outlet, to assist the passage of flow and reduce turbulence.
- (b) Pits without a sump, as shown in Figure 8.4(a), shall have the floor graded to fall at least 20 mm between the inverts of the inlet and outlet pipes. Sump pits shall have a flat floor, but a fall of at least 20 mm between pipe inverts, as shown in Figure 8.4(b).

8.6.4 Inlets

Gratings or slotted kerb inlets of sufficient size to admit the flows shall be provided, as specified in Clause 5.4.10. Where pits act as surcharge outlets, the provisions of Clause 5.4.12 shall apply.

For concrete paved areas care should be taken that construction or expansion joints do not coincide with the lines of collecting channels and do not cross areas in which ponding occurs at sag inlets. Gratings shall be set 5 mm below the levels of surrounding paved areas to allow for settlement after construction.

Frames of gratings or inspection covers on pits in areas subject to vehicular traffic shall be bedded using good quality mortar with low-water content on well-built masonry or concrete walls. Sufficient time shall be allowed for the bedding to develop its strength before a grating or cover is subjected to traffic.

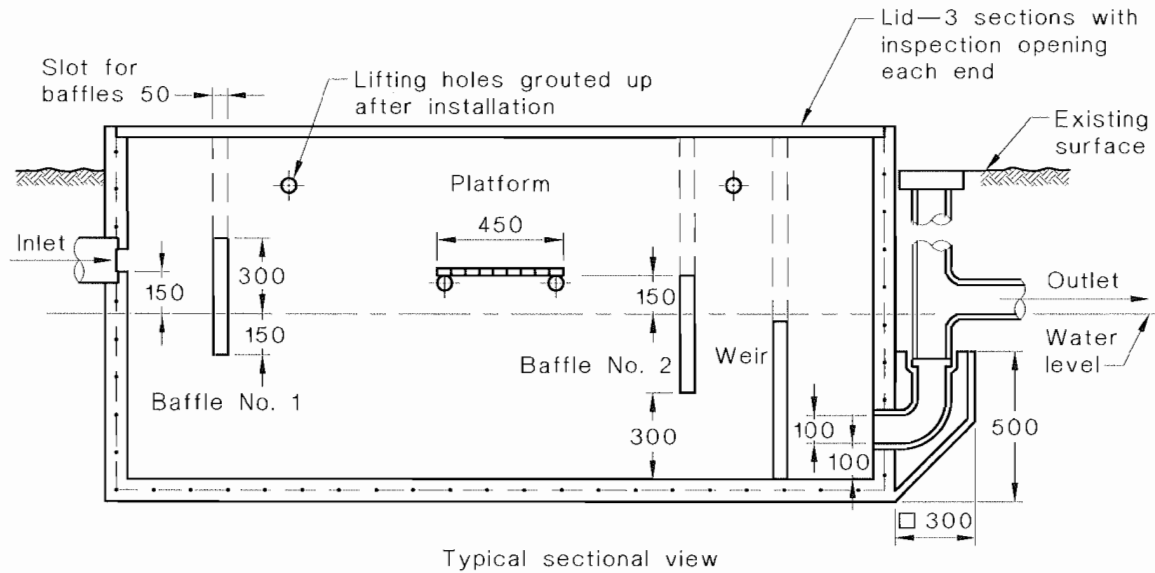

millimetres

| Maximum hourly discharge L | Minimum internal dimensions | | | Minimum spacing of baffles and weir | | | |
|-----------------------------------|-----------------------------|--------|---------------------------|-------------------------------------|------------------------------|----------------------|----------------|
| | Width | Length | Depth below crest of weir | Inlet to baffle No. 1 | Baffle No. 1 to baffle No. 2 | Baffle No. 2 to weir | Weir to outlet |
| 500 | 600 | 1 870 | 700 | 200 | 1 200 | 150 | 200 |
| 750 | 600 | 1 870 | 1 000 | 200 | 1 200 | 150 | 200 |
| 1 000 | 700 | 2 660 | 600 | 300 | 1 640 | 300 | 300 |
| 1 500 | 700 | 3 020 | 600 | 300 | 2 000 | 300 | 300 |
| 2 000 | 1 000 | 3 020 | 780 | 300 | 2 000 | 300 | 300 |
| 3 000 | 1 250 | 3 820 | 1 050 | 300 | 2 500 | 300 | 600 |
| 4 000 | 1 350 | 4 020 | 1 150 | 300 | 2 700 | 300 | 600 |
| 5 000 | 1 450 | 4 020 | 1 250 | 300 | 2 900 | 300 | 600 |

DIMENSIONS IN MILLIMETRES

FIGURE 8.3 TYPICAL MINIMUM DIMENSIONS FOR GENERAL PURPOSE (OIL OR SILT OR BOTH) ARRESTERS

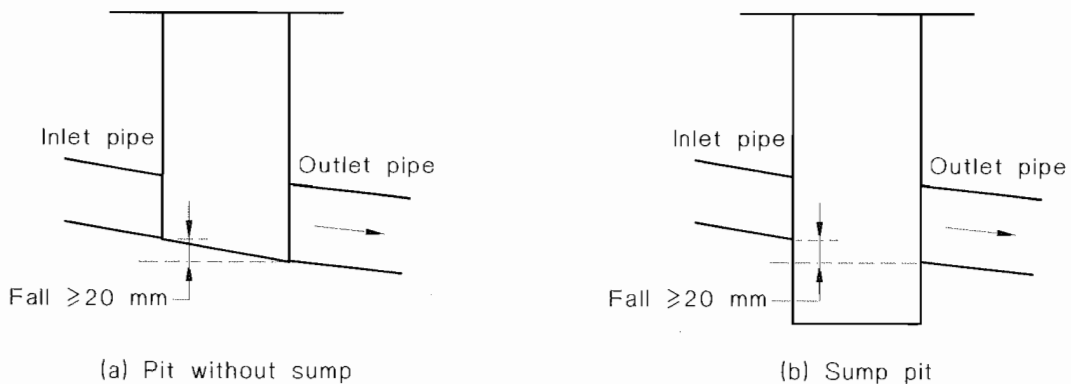

FIGURE 8.4 PIT ARRANGEMENTS

8.6.5 Materials and construction

8.6.5.1 Rectangular or square pits and arresters

Rectangular or square stormwater pits and inlet pits and all arresters shall be either one of the following:

- (a) Constructed in situ on a concrete bed with at least the same external dimensions as the pit or arrester and at least 150 mm thick with walls of—
 - (i) brickwork for wall depths, measured from the existing surface to the invert of the outlet, that—
 - (A) do not exceed 600 mm, at least 110 mm thick; or
 - (B) exceed 600 mm but not 1500 mm, at least 230 mm thick;
 - (ii) non-reinforced concrete with thickness not less than that determined from Figure 8.5; or
 - (iii) reinforced concrete with thickness and reinforcement determined by a professional engineer.
- (b) Precast or prefabricated in accordance with Clause 2.13.8.

8.6.5.2 Circular pits

Circular stormwater pits and inlet pits shall be pre-cast or prefabricated in accordance with Clause 2.12.8.

8.6.5.3 Conduits and channels

The conduits and channels in pits shall be constructed in accordance with the following:

- (a) The fall from the invert of each inlet to the invert of the outlet shall not be less than the values given in Figure 8.4.
- (b) For pits located inside buildings, flows shall be conveyed through the pit by—
 - (i) a fully enclosed conduit with sealed inspection openings; or
 - (ii) a graded floor, with the pit fitted with an airtight cover.
- (c) For pits located outside buildings, flows shall be conveyed through the pit—
 - (i) as specified for Item (b)(i); or
 - (ii) by a graded floor or sump.

Inlet pits in locations subject to dengue fever borne by mosquitoes shall be without a sump and be self-draining.

8.6.5.4 Ladders

Rung and individual-rung ladders installed in pits and arresters shall comply with AS 4198 and AS 1657, respectively.

Following manufacture, steel ladders shall be hot dip zinc galvanized as specified in AS/NZS 4680.

8.6.5.5 Cement rendering

Brick walls and floors of pits and arresters shall be rendered with a coat of cement mortar at least 10 mm thick, trowelled to a smooth finish.

8.6.5.6 Upper walls of stormwater pits

The upper walls of stormwater pits shall be—

- (a) vertical; or

- (b) tapered upwards to the access shaft from a point not less than—
- (i) 1500 mm above the invert of the outlet pipe; and
 - (ii) 100 mm above the top of the highest inlet pipe.

The diameter of the access shaft shall be not less than 600 mm, and its length shall be not greater than 350 mm.

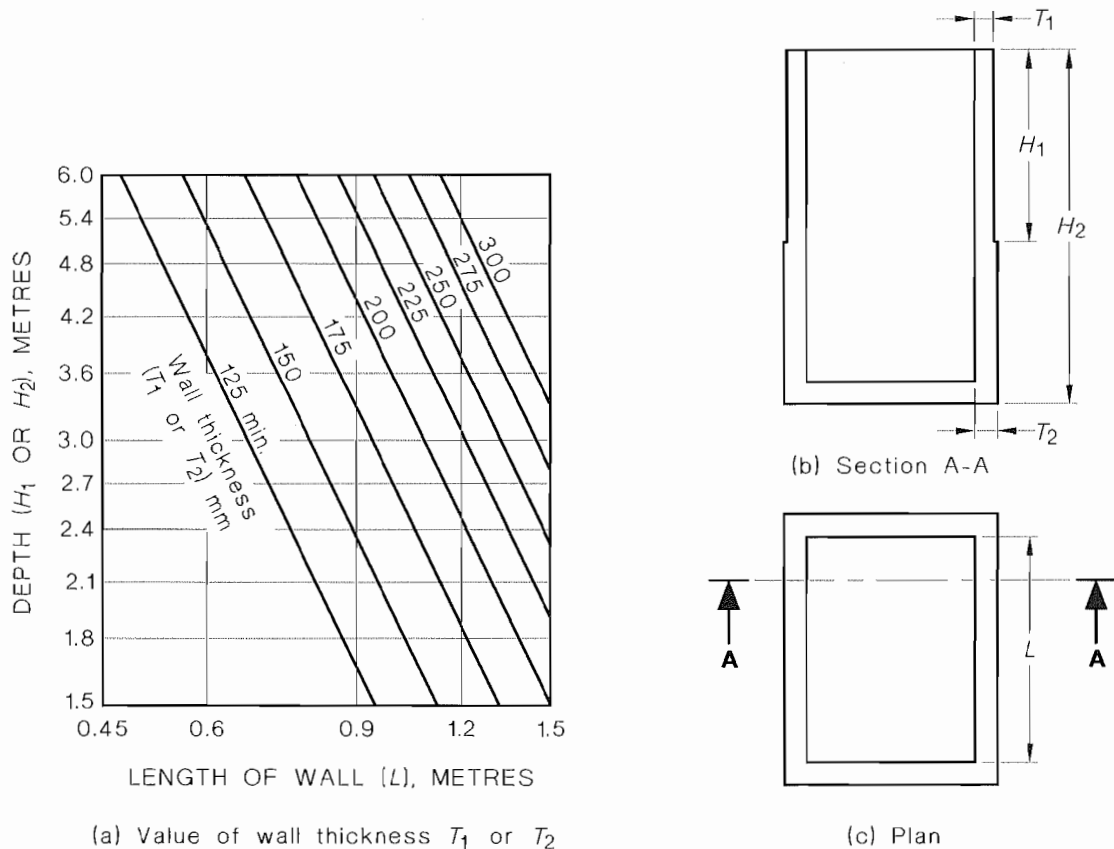

Example:

For a non-reinforced concrete wall of length (L) = 1.2 m, and maximum depths of 1.8 m (H_1) and 2.4 m (H_2) the thicknesses are 175 mm (T_1) and 200 mm (T_2), respectively.

NOTE: Thickness T_2 obtained from the graph applies to the thickness of the bottom section, and T_1 to the top section.

FIGURE 8.5 MINIMUM THICKNESS OF NON-REINFORCED CONCRETE WALLS FOR PITS AND SILT ARRESTERS

8.6.5.7 Access openings

Stormwater pits that are not intended to act as inlets for stormwater and for arresters, circular or rectangular access openings shall be fitted at finished surfaces with removable covers with a clear opening of not less than 500 mm.

8.6.5.8 Construction joints

Construction joints shall be made in accordance with the following:

- (a) Not more than 24 h shall elapse between successive pours of concrete.
- (b) The keying surface shall be scabbled and cleaned.
- (c) A thick cement slurry shall be applied immediately prior to pouring concrete.

8.6.5.9 Inserts

Holes broken in or formed in walls of pits and arresters for insertion of pipes or fittings shall be made watertight by—

- (a) keying and preparing as for construction joints and caulking the annular space between the concrete and pipe or fitting with a stiff mortar (see Clause 2.10.5); or
- (b) sealing with an epoxy-based or other sealant authorized by the network utility operator.

8.6.5.10 Connections

Connections to pits and arresters shall comply with Clause 7.3.3.

8.7 SURCHARGE OUTLETS

Surcharge outlets shall comply with Clause 5.4.12.

8.8 JUNCTIONS

8.8.1 General

Junctions in site stormwater drains shall be made by means of—

- (a) an oblique junction or sweep junction at an upstream angle of not greater than 60° , as shown in Figure 8.6, and preferably less than 45° ;
- (b) an opening cut into a site stormwater drain in accordance with Figure 8.7 for nominal pipe sizes equal to or greater than DN 375; or
- (c) a pit.

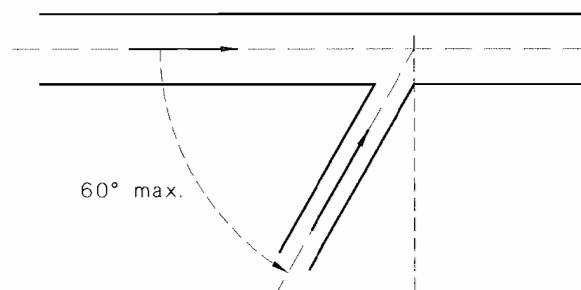
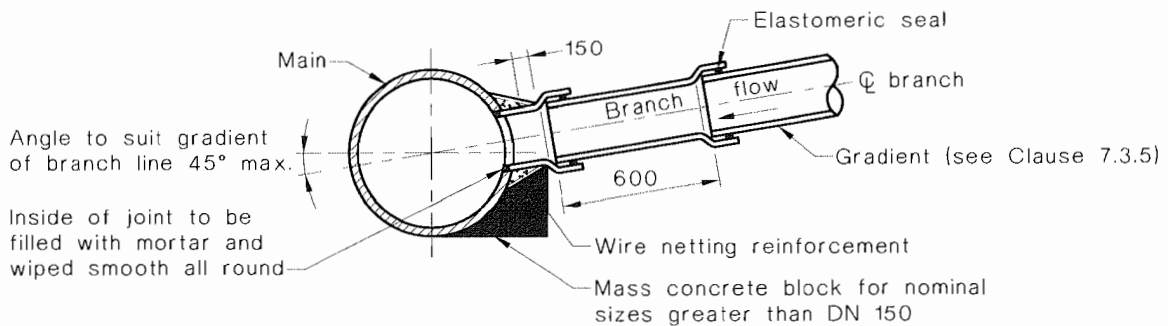

FIGURE 8.6 ALLOWABLE OBLIQUE OR SWEEP JUNCTION CONNECTION



NOTES:

- 1 The centre-line of each branch shall intersect the centre-line of the main line.
- 2 The change of direction of flow at a cut-in shall be between 45° and 90°, as shown in Figure 8.8.

DIMENSIONS IN MILLIMETRES

FIGURE 8.7 CUT-IN CONNECTION FOR SITE STORMWATER DRAINS EQUAL TO OR GREATER THAN DN 375

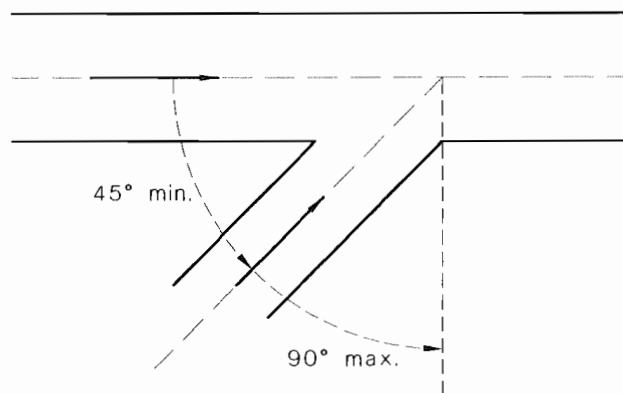

FIGURE 8.8 ALLOWABLE CHANGE OF DIRECTION OF FLOW AT A BRANCH CONNECTION OR CUT-IN

8.8.2 Square junctions

For site stormwater drains square junctions shall only be used—

- (a) at the top of a jump-up at a point of connection;
- (b) as an inspection opening; or
- (c) at the top of a jump-up in the site stormwater drain in lieu of a bend and inspection opening.

8.9 JUMP-UPS

Jump-ups in site stormwater drains shall be constructed in accordance with the following:

- (a) The bend at the base of the jump-up shall be supported on a concrete footing of a thickness not less than 100 mm and extending upwards not less than 100 mm.
- (b) Either a bend incorporating a full-size inspection opening or a junction fitting shall be used at the top of the jump-up (see Figure 8.9).

- (c) Branch site stormwater drains shall connect to the shaft of a jump-up using junction fittings shown in Figure 8.9 and shall be fully supported.
- (d) The jump-up shall be protected and supported during installation and placement of trench fill.

8.10 ANCHOR BLOCKS

Where the gradient of a site stormwater drain exceeds 1:5, anchor blocks shall be installed—

- (a) at the bend or junction at the top and bottom of the inclined site stormwater drain (see Figure 8.10); and
- (b) at intervals not exceeding 3 m.

Anchor blocks for such drains shall be of reinforced concrete—

- (i) with a thickness of not less than 150 mm;
- (ii) with steel reinforcement for such drains of nominal sizes—
 - (A) DN 100 or DN 150, two bars of not less than 10 mm diameter bent to a radius of about 200 mm or 250 mm, respectively and placed as shown in Figure 8.10.
 - (B) greater than DN 150, shall be designed by a suitably qualified competent person;
- (iii) which extends—
 - (i) across the full width and is firmly keyed into the sides of the trench;
 - (ii) above the top of such drain by not less than 150 mm; and
 - (iii) below the foundation of the trench by not less than 150 mm; and
- (iv) which does not cover any flexible joint.

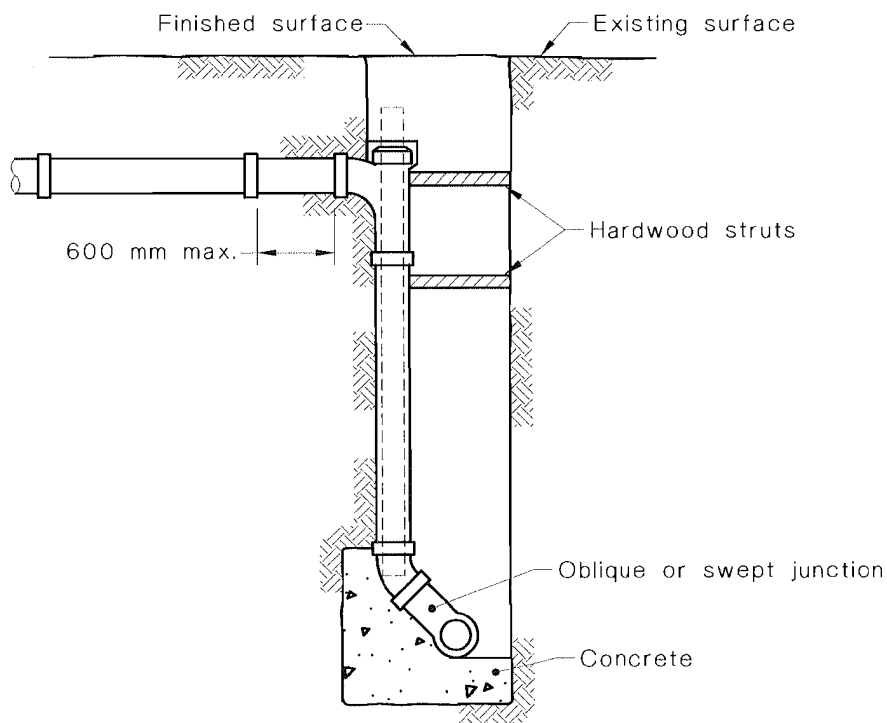

FIGURE 8.9 VERTICAL JUMP-UP TO BRANCH SITE STORMWATER DRAIN

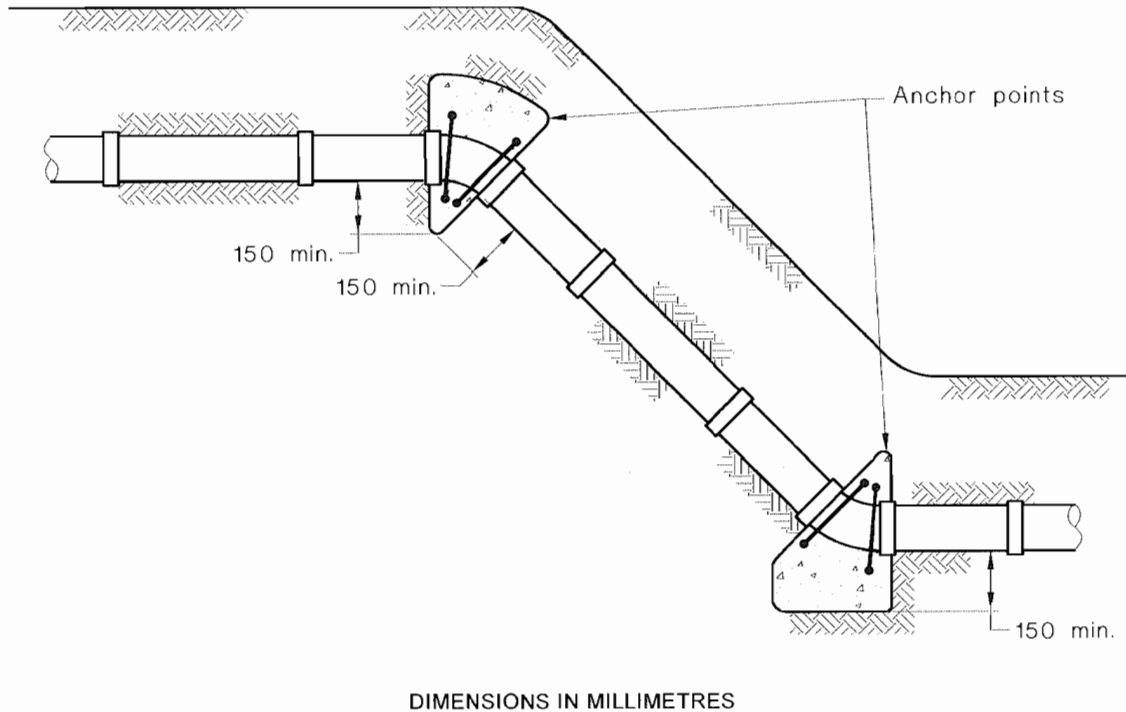

FIGURE 8.10 ANCHORING OF SITE STORMWATER DRAINS

8.11 ON-SITE STORMWATER DETENTION (OSD) SYSTEMS

8.11.1 General criteria

OSD systems, located both above and below ground, shall comply with the following:

- (a) Provision shall be made for the harmless escape of overflows in the event that an outlet gets blocked and the storage is completely filled. Any ponding of water resulting from a blockage shall occur at a visible location, so that the fault can be noticed and corrected.
- (b) Ponding and overflow levels shall be not less than 300 mm below any adjacent habitable floor levels of buildings and not less than 150 mm below non-habitable floor levels.

8.11.2 Above-ground systems

For OSD systems located above the ground, the following criteria are recommended:

- (a) In landscaped areas—
 - (i) a desirable minimum slope for surfaces draining to an outlet be 1:60, and an absolute minimum slope be 1:100;
 - (ii) the desirable maximum depth of ponding under design conditions be 300 mm;
 - (iii) required storage volumes in landscaping areas be increased by 20% to allow for vegetation growth, construction inaccuracies and possible filling;
 - (iv) subsoil drains be provided around outlets to prevent the ground becoming saturated during prolonged wet weather; and
 - (v) where the storage is located in areas where frequent ponding could cause maintenance problems or inconvenience, the first 10% to 20% of the storage required be in an area which can tolerate frequent inundation, such as a paved outdoor entertainment area, a small underground tank, a permanent water feature, or a rockery.

- (b) In driveway and car park storages—
 - (i) depths of ponding to not exceed 200 mm under design conditions;
 - (ii) transverse paving slopes within storages be not less than 1:140; and
 - (iii) where the storage is located in commonly used areas where ponding would cause inconvenience, part the storage required be provided in an area or form which will not cause a nuisance.

NOTE: The appropriate proportion of the storage will depend on the local rainfall climate, but 15% would be an indicative value. As a further guide, ponding outside this area should only occur approximately once every year, on average.

8.11.3 Below ground systems

OSD systems located in underground tanks shall comply with the following:

- (a) The hydraulic control for the storage, usually an orifice plate on an outlet pipe, shall be firmly fixed in place to prevent removal or tampering. (A suitable plate may be of 3 to 5 mm thick stainless steel with a circular hole of the diameter required by the designer machined to 0.5 mm accuracy. The machined hole is to retain a sharp edge.) The orifice diameter shall be not less than 25 mm.
- (b) For tanks with open storage zones, allowance shall be made for the accumulation of debris and sediment in the storage, as follows:
 - (i) Floors of tanks shall be graded at a minimum slope of 1:140 towards the outlet, to minimize ponding and depositing of debris.
 - (ii) An inspection/access opening shall be provided above the location of the outlet with dimensions at least 600 mm × 600 mm or 600 mm diameter for storages up to 800 mm deep and 600 mm × 900 mm for deeper storages. There shall be no impediments to the removal of debris through this opening. Inspection shall be possible without residents or owners having to remove heavy access covers.
 - (iii) When storages are not sufficiently deep to work in (i.e., less than 1.5 m deep), access shall be provided at intervals of approximately 10 m to allow the system to be flushed to the storage outlet. Adequate access shall be provided at the outlet.
 - (iv) A sump (with a base level set below that of the main storage) shall be provided at the outlet point, set below the level of the main storage to collect debris. Where a discharge control pit is included in the storage, this shall contain a sump set a minimum of 1.5 times the diameter of the orifice of the outlet below the centre of the orifice. Sumps shall be provided with adequate weepholes to drain out to the surrounding soil, and shall be founded on a compacted granular base.
- (c) Where the depth of the tank exceeds 1.2 m, a ladder in accordance with Clause 8.6.6.2 shall be installed.
- (d) Below ground OSD systems shall comply with AS/NZS 2865.

It is recommended that underground tanks comply with the following:

- (A) Screens with the following characteristics be provided to cover each orifice outlet:
 - (1) For orifices up to 150 mm diameter, a fine aperture-expanded metal mesh screen (BHP Maximesh Rh3030 or equivalent) with a minimum area of 50 times the area of the orifice. For larger diameter orifices, a coarser grid mesh with a minimum area of 20 times the orifice area may be used as an alternative.
 - (2) Steel screens be of stainless steel or hot-dipped galvanized.

- (3) Where aperture-expanded mesh screens are employed, they be positioned so that the oval-shaped holes are horizontal, with the protruding lip angled upwards and facing downstream. A handle may be fitted to ensure correct orientation and easy removal for maintenance.
 - (4) Screens be located so that they are at least 1.5 times the orifice diameter or 200 mm from the orifice plate, whichever is the greater.
 - (5) Screens be placed no flatter than 45° to the horizontal in shallow storages up to 600 mm deep. In deeper or more remote locations, the minimum angle should be 60° to the horizontal.
- (B) If the storage is sealed, a vent be provided to expel any noxious gases.
- (C) The storage be designed to fill without causing overflows in upstream conduits due to backwater effects.

NOTE: A system may provide a cellular storage volume rather than an open void, and some may permit infiltration to the surrounding soil.

8.11.4 Materials

Storages shall be constructed of concrete, masonry, aluminium/zinc alloy-coated steel, zinc-coated steel, galvanized iron or plastics.

SECTION 9 PUMPED SYSTEMS

9.1 SCOPE OF SECTION

This Section specifies criteria for pumped systems.

9.2 GENERAL

Pumped systems are for areas normally less than 2000 m² where it is not possible for the stormwater to be discharged by gravity through the available gravitational point of connection.

The pumping equipment shall include a wet well, pumps and motors, pipework and electrical equipment and be located to facilitate easy connection to either the surface water system or the pumped point of connection.

NOTE: An illustration of the application of this Section is given in Appendix L.

9.3 WET WELLS

9.3.1 General

Wet wells, for submersible or non-submersible type pumps, shall be installed in accessible locations.

9.3.2 Construction and materials

The structure shall be sound and constructed of materials that will resist corrosion from ground water and aggressive soils.

Authorized materials include pre-cast or cast in situ reinforced concrete, corrosion-resistant metals, brickwork or glass-reinforced plastics.

9.3.3 Base

The base shall be constructed of materials compatible with the walls and shall maintain a self-cleansing gradient towards the pump inlet. The base shall be supported on stable ground.

9.3.4 Cover

The cover shall be constructed of similar materials to that of the wet well and shall have removable access openings sized for maintenance purposes. If the access opening is airtight, a breather pipe with a non-corrodible screen shall be installed.

9.3.5 Ladders

Where a wet well exceeds a depth of 1.2 m, a ladder, in accordance with Clause 8.6.5.4, shall be installed.

9.3.6 Combined effective storage

The capacity of the pumped system shall be achieved by a combination of pump capacity and wet well storage between the high and low working levels of the wet well. The combined effective storage comprising the volume able to be pumped in 30 min plus the wet well storage shall not be less than the volume of the run-off from the storm of ARI = 10 years and duration of 120 min, or as otherwise directed by the authority having jurisdiction. The maximum pump capacity shall be as detailed in Clause 9.4(a). The minimum wet well storage between the high and low working levels expressed in cubic metres shall be 1% of the catchment area in m² but in any case shall not be less than 3 m³.

NOTE: The minimum pump capacity should be 10 L/s.

9.3.7 Alarm

High-level and low-level alarms shall be installed in each wet well and located clear of the discharge from the inlet pipe so that false alarms are prevented. The high level alarm should be set no higher than 100 mm above the invert of the inlet pipe, provided that flooding of habitable or storage areas and vehicle garages shall be avoided. Where flooding could occur the overflow and high-level alarm shall be lowered accordingly to prevent flooding.

9.3.8 Inlet

The invert of the inlet pipe to the wet well shall be located at least 100 mm above the level of the Design Top Water Level.

9.3.9 Sealing

All pipes or apparatus passing through a wall or cover of a wet well shall be sealed with a compatible material.

9.4 PUMPS

The pumps shall be suitable for unscreened stormwater and shall be installed as follows:

- (a) Pumps shall be in duplicate. The maximum capacity of each pump shall be selected so that the capacity of the system receiving the discharge is not exceeded. The pump controls shall be set up to enable alternate pump operation at each start. In the event that a pump fails to operate when the water level in the wet well reaches the pump start, the other pump shall be activated and a visible alarm initiated. In the event that both pumps fail to operate, an audible alarm shall be initiated.
- (b) Pumping equipment shall be securely fixed to the wet well using corrosion-resistant fixings.
- (c) Pumps shall be fitted with a gate valve and non-return valve on the delivery side of each pump.
- (d) Pumps shall have flanges or unions installed to facilitate removal.
- (e) Pumps shall be controlled so as to limit the number of starts per hour to within the capacity of the electrical motors and equipment, and shall, as far as practicable, empty the contents of the wet well at each operation.
- (f) The required pumping rate shall be calculated based on an assessment of the expected inflow and, where appropriate, the allowable discharge rate.

9.5 RISING MAINS

Rising mains shall comply with the relevant Sections of AS/NZS 3500.1 and this Standard, and connect to—

- (a) a stormwater or inlet pit; or
- (b) direct to a stormwater drain.

9.6 ELECTRICAL CONNECTION

All electrical motors and equipment shall be installed in accordance with AS/NZS 3000.

SECTION 10 SITE TESTING

10.1 SCOPE OF SECTION

This Section specifies criteria for the testing of downpipes within buildings, site stormwater drains and main internal drains under buildings and all rising mains.

10.2 DOWNPIPES, SITE STORMWATER DRAINS AND DRAINS WITHIN OR UNDER BUILDINGS

Downpipes, site stormwater drains and drains within or under buildings shall be tested in accordance with Clause 10.3

10.3 TEST CRITERIA**10.3.1 Downpipes within buildings**

Downpipes within buildings shall be free of leaks when subject to either—

- (a) water test at a pressure of a head of water equal to the lesser of 10 m or the length of the downpipe for a period of not less than 10 min; or
- (b) air test at a pressure of not less than 30 kPa for a period of not less than 3 min.

Note: 1 kPa = 100 mm head of water.

10.3.2 Site stormwater drains, drains within and under buildings and main-internal drains

Site stormwater drains, drains within and under buildings and main internal drains shall be free of leaks when subjected to either of the following:

- (a) *Water test (see Clause 10.4.1)* The leakage rate not to exceed the relevant value given in Table 10.1 for a pressure within the range 1.5 m to 3.0 m head of water maintained for a period of not less than—
 - (i) 10 min for FRC, precast concrete (steel reinforced) and vitrified clay (ceramic) products; or
 - (ii) 5 min for all other authorized products.
- (b) *Air test (see Clause 10.4.2)* Application of a pressure test of not less than 30 kPa for a period of not less than 3 min then, after disconnection of the pressure source, the period for a pressure drop from 25 kPa to 20 kPa to exceed the relevant value given in Table 10.2.

TABLE 10.1
MAXIMUM LEAKAGE RATE

| Material | Maximum leakage rate per 30 m length L/min |
|---|---|
| FRC, precast concrete (steel reinforced) and vitrified clay (ceramic) | $\frac{DN}{1000}$ |
| All other authorized | Nil |

10.3.3 Rising mains

Rising mains shall be free of leaks when subject to a pressure test at a pressure of not less than twice the shut-off head of the pump connected to the rising main, for a period of not less than 10 min.

TABLE 10.2
MINIMUM PERIOD FOR PRESSURE DROP

| Nominal size DN | Minimum period for pressure drop from 25 kPa to 20 kPa s |
|--------------------|---|
| 100 to 225 | 90 |
| 300 to 450 | 180 |

10.4 PROCEDURE

10.4.1 Water test

The head of water on any section of drain shall not exceed 3 m.

The procedure shall be as follows:

- (a) Seal all openings except the top of the section of the below-ground drain to be tested.
- (b) Fill the below-ground drain with water to the highest level in that section.
- (c) Maintain the water at this level for a period of—
 - (i) 10 min for vitrified clay drains, by the addition of measured quantities of make-up water as set out in Item (c); or
 - (ii) 5 min for drains of any other material.

The test is considered to be successful if no make-up water is required.

NOTE: For vitrified clay drains the following quantities of make up water are permitted—

- (a) up to 1 L per 30 m length of DN 100; or
- (b) up to 1.5 L per 30 m length of DN 150.

10.4.2 Air test

The procedure shall be as follows:

- (a) Apply a pressure of 30 kPa to the drain and hold this pressure for 3 min to allow the air temperature to stabilize.
- (b) Shut off the air supply and measure the time taken for the pressure in the pipe to drop from 25 kPa to 20 kPa.

The drain is considered to have passed the test if the time taken is greater than 90 s for pipes of size DN 225 or smaller, or 180 s for pipes of sizes DN 300 and DN 375.

APPENDIX A
REFERENCED AND RELATED DOCUMENTS
(Normative)

A1 REFERENCED DOCUMENTS

The following documents are referred to in this Standard:

AS

- | | |
|------------|--|
| 1074 | Steel tubes and tubulars for ordinary service |
| 1100 | Technical drawing |
| 1100.101 | Part 101: General principles |
| 1167 | Welding and brazing—Filler metals |
| 1167.1 | Filler metal for brazing and braze welding |
| 1273 | Unplasticized PVC (UPVC) downpipe and fittings for rainwater |
| 1289 | Methods of testing soils for engineering purposes |
| 1289.5.4.1 | Method 5.4.1: Soil compaction and density tests—Compaction control test— Dry density ratio, moisture variation and moisture ratio |
| 1289.5.6.1 | Part 5.6.1: Soil compaction and density tests—Compaction control test— Density index method for a cohesionless material |
| 1345 | Identification of the contents of pipes, conduits and ducts |
| 1379 | Specification and supply of concrete |
| 1432 | Copper tubes for plumbing, gasfitting and drainage applications |
| 1478 | Chemical admixtures for concrete, mortar and grout |
| 1478.1 | Part 1: Admixtures for concrete |
| 1604 | Specification for preservative treatment |
| 1604.1 | Part 1: Sawn and round timber |
| 1628 | Water supply—Metallic gate globe and non-return valves |
| 1631 | Cast grey and ductile iron non-pressure pipes and fittings |
| 1657 | Fixed platforms, walkways, stairways and ladders—Design, construction and installation |
| 1665 | Welding of aluminium structures |
| 1761 | Helical lock-seam corrugated steel pipes |
| 1762 | Helical lock-seam corrugated steel pipes—Design and installation |
| 1834 | Material for soldering |
| 1834.1 | Part 1: Solder alloys |
| 2032 | Code of practice for installations of UPVC pipe systems |
| 2033 | Installation of polyethylene pipe systems |
| 2050 | Installation of roof tiles |
| 2200 | Design charts for water supply and sewerage |
| 2439 | Perforated plastics drainage and effluent pipe and fittings |
| 2439.1 | Part 1: Perforated drainage pipe and associated fittings |

- 2638 Gate valves for waterworks purposes
 2638.1 Part 1: Metal seated
 2638.2 Part 2: Resilient seated
- AS
- 2758 Aggregates and rock for engineering purposes
 2758.1 Part 1: Concrete aggregates
- 3517 Capillary fittings of copper and copper alloy for non-pressure sanitary plumbing applications
- 3571 Glass filament reinforced thermosetting plastics (GRP) pipes—Polyester based—Water supply, sewage and drainage applications
- 3578 Cast iron non-return valves for general purposes
- 3600 Concrete structures
- 3648 Specification and methods of test for packaged concrete mixes
- 3673 Malleable cast iron threaded pipe fittings
- 3680 Polyethylene sleeving for ductile iron pipelines
- 3705 Geotextiles—Identification, marking and general data
- 3725 Loads on buried concrete pipes
- 3795 Copper alloy tubes for plumbing and drainage applications
- 3996 Metal access covers, road grates and frames
- 4058 Precast concrete pipes (pressure and non-pressure)
- 4060 Loads on buried vitrified clay pipes
- 4087 Metallic flanges for waterworks purposes
- 4139 Fibre-reinforced concrete pipes and fittings
- 4198 Precast concrete access chambers for sewerage applications
- AS/NZS
- 1167 Welding and brazing—Filler metals
 1167.2 Filler metal for welding
- 1254 PVC pipes and fittings for storm and surface water applications
- 1260 PVC pipes and fittings for drain, waste and vent applications
- 1477 PVC pipes and fittings for pressure applications
- 1170 Structural design actions—General principles
 1170.1 Part 1: Structural design actions—Permanent, imposed and other actions
 1170.3 Part 3: Structural design actions—Snow and ice actions
- 1866 Aluminium and aluminium alloys—Extruded rod, bar, solid and hollow shapes
- 2179 Specifications for rainwater goods, accessories and fasteners
 2179.1 Part 1: Metal shape or sheet rainwater goods, and metal accessories and fasteners
 2179.2(Int) Part 2: PVC rainwater goods and accessories
- 2280 Ductile iron pressure pipes and fittings
- 2312 Guide to the protection of iron and steel against exterior atmospheric corrosion by the user of protective coatings
- 2566 Buried flexible pipelines

- 2566.1 Part 1: Structural design
- 2865 Safe working in a confined space
- 2878 Timber—Classification into strength groups
- 3000 Electrical installations
- 3500 Plumbing and drainage
- 3500.0 Part 0: Glossary of terms
- AS/NZS
- 3500.1 Part 1: Water services
- 3879 Solvent cements and priming fluids for use with unplasticized PVC (uPVC) pipes and fittings
- 4020 Testing of products for use in contact with drinking water
- 4129 Fittings for polyethylene (PE) pipes for pressure applications
- 4130 Polyethylene (PE) pipes for pressure applications
- 4327 Metal-banded flexible couplings for low-pressure applications
- 4401(Int) High-density polyethylene (PE-HD) pipes and fittings for soil and waste discharge (low and high temperature) systems inside buildings—Specifications
- 4455 Masonry units and segmental pavers
- 4671 Steel reinforcing materials
- 4680 Hot-dip galvanized (zinc) coatings on fabricated ferrous articles
- NZS
- 3107 Specification for precast concrete drainage and pressure pipes
- 3631 New Zealand timber grading rules
- 3640 Specification of the minimum requirements of the NZ Timber Preservation Council Inc.
- 5807 Code of Practice for industrial identification by colour, wording or other coding
- BS
- EN 295-1 Vitriified clay pipes and fittings and pipe joints for drains and sewers. Requirements.
- EN 12056-3 Gravity drainage systems inside buildings. Roof drainage, layout and calculation
- 6367 Code of practice for drainage of roofs and paved areas
- 8301 Code of practice for building drainage
- ASTM
- A240 Standard Specification for Chromium and Chromium-Nickel Stainless Steel Plate, Sheet, and Strip for Pressure Vessels and for General Applications
- E1/AS1 NZ Building Code Approved Documents: Acceptable solutions E1/AS1
- ARR87 Australian rainfall and runoff: A guide to flood estimation, Volumes 1 and 2. Revised edition 1998, published by Institution of Engineers Australia
- BCA Building Code of Australia: Volume 1—Class 1 and Class 10 Buildings—Housing Provisions; Volume 2—Class 2 to Class 9 Buildings, Australian Building Codes Board

PCA Plumbing Code of Australia

A2 RELATED DOCUMENTS

Attention is drawn to the following related documents:

- 1 Beecham S.C., Jones R.F., O'Loughlin G.G. (1995), Hydraulic testing of box and valley gutters for roof drainage design, Second International Symposium on Urban Stormwater Management, Institution of Engineers, Australia.
- 2 Argue, J.R. (1986), Storm drainage design in small urban catchments: a handbook for Australian practice, Special Report No. 34, Australian Road Research Board, Vermont South.
- 3 Neville Jones & Associates Pty Ltd and Australian Water Engineering (1992), Queensland Urban Drainage Manual, 2 volumes, Queensland Water Resources Commission, the Local Government Engineers' Association of Queensland and Brisbane, City Council, Brisbane.
- 4 ACT Department of Urban Services (1994), Urban Stormwater, Edition 1, Standard Engineering Practices, Australian Government Publishing Service, Canberra.
- 5 Upper Parramatta River Catchment Trust (1999) On-site Stormwater Detention Handbook, 3rd Edition, Parramatta (available from www.uprct.nsw.gov.au).
- 6 Sydney Coastal Councils Group, On-Site Stormwater Detention Guidelines for Urban Councils (draft), Sydney, 1995.
- 7 Martin K. G. and Tilley R.I, 1968. Influence of slope upon discharge capacities of roof drainage channels CSIRO Aust. Division of Building Research. Rpt. 0.2.2-32.
- 8 REBUILD, December 1976, published by CSIRO, Division of Building Research.
- 9 New Zealand Building Code, published in New Zealand. Building Industry Authority.
- 10 General drainage manuals prepared by other authorities, and manuals prepared by municipal councils for local use.
- 11 Ralph Jones & Eugene Klöti (1999) A High Capacity Overflow Device for Internal Box Gutters of Roofs. 8th International Conference on Urban Storm Drainage 30.8.99 to 3.9.99, Institution of Engineers, Australia.

APPENDIX B

SITE-MIXED CONCRETE FOR MINOR WORKS

(Informative)

Minor works are deemed to be works of a minor nature in which the strength of the concrete is not critical. For such works it is permissible for the designer to specify the proportions given in Table B1. Strength tests are not required for minor works.

It is permissible to adjust the proportions of fine and coarse aggregates given in Table B1 so long as the ratio there stated of total aggregate to cement is not changed.

TABLE B1

CONCRETE MIX PROPORTIONS FOR MINOR WORKS

(The proportions listed in this Table do not apply to lightweight concrete and concrete made with blended cement)

| 1 | 2 | 3 | 4 | 5 | 6 |
|---|----------------|------------------|---------------|------------------------------------|------------------|
| Mix proportions by mass for saturated surface-dry dense aggregate | | | Maximum slump | Maximum water/cement ratio by mass | Nominal strength |
| Cement | Fine aggregate | Coarse aggregate | mm | | MPa |
| 1 | 2½ | 4 | 100 | 0.70 | 15 |
| 1 | 2 | 3 | 100 | 0.58 | 20 |

APPENDIX C
STORMWATER DRAINAGE INSTALLATION PLANS
(Informative)

C1 SCOPE

This Appendix sets out guidelines for the use of network utility operators, to indicate the information that may be included in stormwater drainage installation plans.

Where requested these plans may comprise—

- (a) a roof plan for all building to be fitted with rainwater goods;
- (b) a site plan;
- (c) where applicable, a catchment plan; and
- (c) computation sheets for the general method.

C2 ROOF PLAN

C2.1 Building with fewer than four floor levels

Roof plans for buildings with fewer than four floor levels should be drawn to a scale not smaller than 1:100 and show—

- (a) extent and slope of roofs for each building and details of any adjacent parapets or vertical walls; and
- (b) proposed layout, sizes and, as applicable, gradients of gutters, downpipes, overflow devices and surcharge outlets.

C2.2 Buildings with four or more floor levels

Roof plans for buildings with four or more floor levels should comprise—

- (a) the information required in Paragraph C2.1; and
- (b) an isometric line diagram (see AS 1100.101), or such other three dimensional representation authorized by the network utility operator, to show the catchment area, location, size and, if applicable, the gradient of each downpipe.

C3 SITE PLAN

Site plans should be drawn to a scale not smaller than 1:500 and in Australia to the Australian Height Datum (AHD) or in New Zealand to the datum authorized by the network utility operator and show—

- (a) boundaries and topography of the property, i.e., spot levels or contours to the appropriate datum;
- (b) location of all existing and proposed buildings and the levels of ground and basement floors, to the appropriate datum;
- (c) location(s) and invert level(s) of the point(s) of connection for the property;
- (d) proposed layout, sizes, invert levels and gradients of the elements, including overflow paths for storms of the surface water drainage system.
- (e) proposed layout and sizes of elements of the subsoil drainage system; and
- (f) vehicular washing areas.

C4 CATCHMENT PLAN

Catchment plans should be drawn to a scale not smaller than that authorized by the network utility operator and show—

- (a) boundaries of the property; and
- (b) limits and topography of the catchment area(s) draining to the property, to the appropriate datum.

C5 COMPUTATION SHEETS

Computation sheets under the general method should clearly show the basic assumptions and the calculations necessary for the sizing of the elements specified in Paragraphs C2 and C3.

APPENDIX D
GUIDELINES FOR DETERMINING RAINFALL INTENSITIES
(Informative)

D1 SCOPE

This Appendix sets out guidelines for determining for any place in—

- (a) Australia, rainfall intensities for 5 min duration and ARIs of 20 and 100 years; and
- (b) New Zealand, rainfall intensities for 10 min duration and ARIs of 10 and 50 years.

NOTE: Significant inaccuracies can occur for any ARI that exceeds the available period of rainfall records. The expected probability is discussed in ARR87.

D2 PROCEDURES

D2.1 Australia

The procedure for the determination of rainfall intensities, in millimetres per hour, for the place considered is as follows:

- (a) If given in Table E1 and—
 - (i) shown in Figures E2 to E13, either—
 - (A) read directly from the relevant Figure; or
 - (B) submit the latitude and longitude (see Table E1) with a request for the required rainfall intensities to the Hydrometeorological Advisory Services of the Bureau of Meteorology (HASBM)*; or
 - (ii) not shown in Figures E2 to E13, either—
 - (A) plot its position (see Table E1) on the relevant Figure and read directly from the Figure; or
 - (B) repeat Step (a)(i)(B).
- (b) If not given in Table E1, determine the latitude and longitude from a map of an appropriate scale and either—
 - (i) plot its position on and read directly from the relevant Figure; or
 - (ii) submit the latitude and longitude with a request for the required rainfall intensities to the HASBM*.

D2.2 New Zealand

The procedures for the determination of rainfall intensities, in millimetres per hour, for the place considered is as follows:

- (a) If shown in Figures F1 to F4, read directly from the relevant Figure (see Paragraph F2).
- (b) If not shown in Figures F1 to F4, determine the latitude and longitude from a map of an appropriate scale and either—
 - (i) plot its position on and read directly from the relevant Figure; or
 - (ii) submit the latitude and longitude with a request for the required rainfall intensity to the National Institute for Water and Atmosphere (NIWA).

* Although a service fee is charged, this is the preferred option for applications that require a high degree of accuracy or for places where there is a significant gradient between the isopleths (lines of equal rainfall intensity) on the relevant Figure, or both.

APPENDIX E
RAINFALL INTENSITIES FOR AUSTRALIA—5 MIN DURATION
(Normative)

E1 SCOPE

This Appendix gives 5 min duration rainfall intensities, for any place in Australia, that are based on the Computerized Design Intensity—frequency—duration Rainfall System (CDIRS) data of the Bureau of Meteorology, used for the sizing of—

- (a) rainwater goods (see Clause 3.3.5.1); and
- (b) surface water drainage systems (see Clause 5.4.5(a)).

E2 SELECTED PLACE REFERENCES

For selected places in Australia, the area number (see Figure E1), the latitude and longitude and the reference figure (Figures E2 to E13) are given in Table E1.

TABLE E1
SELECTED PLACE REFERENCES

| Place | Area number | Latitude south | Longitude east | Reference figure | |
|-----------------|-------------|----------------|----------------|------------------|-----|
| | | | | ARI, years | |
| | | | | 20 | 100 |
| Abydos | 6 | 21.47° | 118.92° | E12 | E13 |
| Adelaide (CBD) | 3 | 34.93° | 138.60° | E6 | E7 |
| Albany | 6 | 35.03° | 117.88° | E12 | E13 |
| Albury | 3 | 36.08° | 146.91° | E6 | E7 |
| Alice Springs | 3 | 23.70° | 133.88° | E6 | E7 |
| Arkaroola | 3 | 30.32° | 139.33° | E6 | E7 |
| Armidale | 1 | 30.50° | 151.67° | E2 | E3 |
| Bacchus Marsh | 3 | 37.68° | 144.44° | E6 | E7 |
| Ballarat | 3 | 37.56° | 143.86° | E6 | E7 |
| Batemans Bay | 2 | 35.71° | 150.18° | E4 | E5 |
| Bathurst | 2 | 33.42° | 149.56° | E4 | E5 |
| Benalla | 3 | 36.55° | 145.98° | E6 | E7 |
| Biloela | 5 | 24.40° | 150.51° | E10 | E11 |
| Bowral | 2 | 34.48° | 150.42° | E4 | E5 |
| Bridgewater | 4 | 42.74° | 147.24° | E8 | E9 |
| Brisbane (CBD) | 1 | 27.47° | 153.03° | E2 | E3 |
| Broken Hill | 3 | 31.93° | 141.47° | E6 | E7 |
| Broome | 6 | 17.96° | 122.24° | E12 | E13 |
| Bunbury | 6 | 33.33° | 115.64° | E12 | E13 |
| Bundaberg | 5 | 24.87° | 152.35° | E10 | E11 |
| Burnie | 4 | 41.05° | 145.91° | E8 | E9 |
| Cairns | 5 | 16.93° | 145.78° | E10 | E11 |
| Canberra (CBD) | 2 | 35.28° | 149.12° | E4 | E5 |
| Cape York | 3 | 11.45° | 142.43° | E6 | E7 |
| Carnarvon | 6 | 24.89° | 113.66° | E12 | E13 |
| Casino | 1 | 28.87° | 153.05° | E2 | E3 |
| Ceduna | 3 | 32.13° | 133.68° | E6 | E7 |
| Charleville | 3 | 26.41° | 146.24° | E6 | E7 |
| Charters Towers | 5 | 20.08° | 146.26° | E10 | E11 |
| Cloncurry | 3 | 20.71° | 140.51° | E6 | E7 |
| Coffs Harbour | 1 | 30.30° | 153.12° | E2 | E3 |
| Collie | 6 | 33.36° | 116.16° | E12 | E13 |
| Cooma | 2 | 36.23° | 149.11° | E4 | E5 |
| Coonabarabran | 1 | 31.28° | 149.27° | E2 | E3 |
| Cowra | 3 | 33.84° | 148.69° | E6 | E7 |
| Dampier | 6 | 20.66° | 116.71° | E12 | E13 |
| Darwin | 3 | 12.46° | 130.84° | E6 | E7 |
| Deloraine | 4 | 41.53° | 146.65° | E8 | E9 |
| Derby | 6 | 17.31° | 123.63° | E12 | E13 |
| Dorrigo | 1 | 30.34° | 152.71° | E2 | E3 |
| Dover | 4 | 43.31° | 147.01° | E8 | E9 |
| Dubbo | 3 | 32.35° | 148.61° | E6 | E7 |

(continued)

TABLE E1 (continued)

| Place | Area number | Latitude south | Longitude east | Reference figure | |
|-----------------|-------------|----------------|----------------|------------------|-----|
| | | | | ARI, years | |
| | | | | 20 | 100 |
| Emerald | 5 | 23.52° | 148.16° | E10 | E11 |
| Flinders Island | 4 | 40.03° | 148.05° | E8 | E9 |
| Forbes | 3 | 33.38° | 148.00° | E6 | E7 |
| Geelong | 3 | 38.15° | 144.36° | E6 | E7 |
| Geraldton | 6 | 28.78° | 114.61° | E12 | E13 |
| Glen Innes | 1 | 29.74° | 151.74° | E2 | E3 |
| Goondiwindi | 1 | 28.55° | 150.30° | E2 | E3 |
| Gosford | 2 | 33.43° | 151.34° | E4 | E5 |
| Goulburn | 2 | 34.76° | 149.72° | E4 | E5 |
| Gympie | 1 | 26.19° | 152.66° | E2 | E3 |
| Halls Creek | 6 | 18.23° | 127.66° | E12 | E13 |
| Hamersley | 6 | 31.85° | 115.79° | E12 | E13 |
| Hamilton | 3 | 37.75° | 142.01° | E6 | E7 |
| Healesville | 3 | 37.65° | 145.52° | E6 | E7 |
| Hillside | 2 | 33.58° | 150.97° | E4 | E5 |
| Hobart (CBD) | 4 | 42.88° | 147.33° | E8 | E9 |
| Horsham | 3 | 36.71° | 142.20° | E6 | E7 |
| Hughenden | 5 | 20.84° | 144.20° | E10 | E11 |
| Innisfail | 5 | 17.52° | 146.03° | E10 | E11 |
| Inverell | 1 | 29.78° | 151.11° | E2 | E3 |
| Kalgoorlie | 6 | 30.75° | 121.47° | E12 | E13 |
| Katanning | 6 | 33.68° | 117.55° | E12 | E13 |
| Katherine | 3 | 14.46° | 132.30° | E6 | E7 |
| Kempsey | 1 | 31.08° | 152.84° | E2 | E3 |
| Kiama | 2 | 34.67° | 150.85° | E4 | E5 |
| Kiandra | 3 | 35.48° | 148.87° | E6 | E7 |
| Kingaroy | 1 | 26.55° | 151.84° | E2 | E3 |
| Kingston | 4 | 42.98° | 147.31° | E8 | E9 |
| Korumburra | 3 | 38.43° | 145.82° | E6 | E7 |
| Kununurra | 6 | 15.77° | 128.74° | E12 | E13 |
| Lakes Entrance | 3 | 37.88° | 147.99° | E6 | E7 |
| Launceston | 4 | 41.44° | 147.14° | E8 | E9 |
| Lismore | 1 | 28.81° | 153.28° | E2 | E3 |
| Lithgow | 2 | 33.48° | 150.13° | E4 | E5 |
| Longreach | 5 | 23.45° | 144.25° | E10 | E11 |
| Mackay | 5 | 21.15° | 149.19° | E10 | E11 |
| Maitland | 1 | 32.74° | 151.56° | E2 | E3 |
| Marble Bar | 6 | 21.17° | 119.74° | E12 | E13 |
| Mareeba | 5 | 16.99° | 145.42° | E10 | E11 |
| Meekatharra | 6 | 26.60° | 118.50° | E12 | E13 |
| Melbourne (CBD) | 3 | 37.82° | 144.96° | E6 | E7 |
| Merimbula | 2 | 36.89° | 149.91° | E4 | E5 |
| Mildura | 3 | 34.19° | 142.16° | E6 | E7 |
| Mittagong | 2 | 34.45° | 150.45° | E4 | E5 |

(continued)

TABLE E1 (continued)

| Place | Area number | Latitude south | Longitude east | Reference figure | |
|----------------|-------------|----------------|----------------|------------------|-----|
| | | | | ARI, years | |
| | | | | 20 | 100 |
| Morwell | 3 | 38.24° | 146.40° | E6 | E7 |
| Mt Barker | 3 | 35.07° | 138.86° | E6 | E7 |
| Mt Gambier | 3 | 37.83° | 140.78° | E6 | E7 |
| Mt Isa | 3 | 20.73° | 139.49° | E6 | E7 |
| Mt Morgan | 5 | 23.65° | 150.39° | E10 | E11 |
| Mt Wellington | 4 | 147.23° | 42.90° | E8 | E9 |
| Mullumbimby | 1 | 28.56° | 153.50° | E2 | E3 |
| Mundaring | 6 | 31.90° | 116.16° | E12 | E13 |
| Murray Bridge | 3 | 35.12° | 139.27° | E6 | E7 |
| Murwillumbah | 1 | 28.33° | 153.39° | E2 | E3 |
| Muswellbrook | 1 | 32.27° | 150.89° | E2 | E3 |
| Newcastle | 1 | 32.93° | 151.78° | E2 | E3 |
| Newman | 6 | 23.36° | 119.73° | E12 | E13 |
| New Norfolk | 4 | 42.78° | 147.06° | E8 | E9 |
| Noosa | 1 | 26.41° | 153.09° | E2 | E3 |
| Nowra | 2 | 34.88° | 150.60° | E4 | E5 |
| Nuriootpa | 3 | 34.48° | 138.99° | E6 | E7 |
| Orange | 2 | 33.29° | 149.10° | E4 | E5 |
| Orbost | 3 | 37.71° | 148.46° | E6 | E7 |
| Perth (CBD) | 6 | 31.95° | 115.86° | E12 | E13 |
| Port Augusta | 3 | 32.49° | 137.76° | E6 | E7 |
| Port Hedland | 6 | 20.31° | 118.57° | E12 | E13 |
| Port Macquarie | 1 | 31.43° | 152.91° | E2 | E3 |
| Port Pirie | 3 | 33.18° | 138.00° | E6 | E7 |
| Proserpine | 5 | 20.40° | 148.58° | E10 | E11 |
| Queenstown | 4 | 42.08° | 145.57° | E8 | E9 |
| Robertson | 2 | 34.59° | 150.59° | E4 | E5 |
| Rockhampton | 5 | 23.38° | 150.51° | E10 | E11 |
| Roma | 3 | 26.57° | 148.80° | E6 | E7 |
| Roy Hill | 6 | 22.60° | 119.95° | E12 | E13 |
| Scottsdale | 4 | 41.16° | 147.52° | E8 | E9 |
| Singleton | 1 | 32.61° | 151.17° | E2 | E3 |
| Sorell | 4 | 42.79° | 147.56° | E8 | E9 |
| Southport | 1 | 27.97° | 153.41° | E2 | E3 |
| Stawell | 3 | 37.06° | 142.78° | E6 | E7 |
| St Helens | 4 | 41.32° | 148.24° | E8 | E9 |
| St Marys | 4 | 41.58° | 148.18° | E8 | E9 |
| Swansea | 4 | 42.12° | 148.07° | E8 | E9 |
| Sydney (CBD) | 2 | 33.87° | 151.21° | E4 | E5 |
| Taree | 1 | 31.91° | 152.46° | E2 | E3 |
| Tom Price | 6 | 22.69° | 117.79° | E12 | E13 |
| Toowoomba | 1 | 27.56° | 151.96° | E2 | E3 |
| Townsville | 5 | 19.26° | 146.82° | E10 | E11 |
| Tweed Heads | 1 | 28.17° | 153.54° | E2 | E3 |

(continued)

TABLE E1 (*continued*)

| Place | Area number | Latitude south | Longitude east | Reference figure | |
|------------|-------------|----------------|----------------|------------------|-----|
| | | | | ARI, years | |
| | | | | 20 | 100 |
| Warwick | 1 | 28.22° | 152.03° | E2 | E3 |
| Weipa | 3 | 12.63° | 141.88° | E6 | E7 |
| Wittenoom | 6 | 22.24° | 118.33° | E12 | E13 |
| Wollongong | 2 | 34.43° | 150.89° | E4 | E5 |
| Wonthaggi | 3 | 38.61° | 145.59° | E6 | E7 |
| Wyong | 2 | 33.29° | 151.42° | E4 | E5 |
| Yorketown | 3 | 35.02° | 137.60° | E6 | E7 |

E3 FIVE MINUTES DURATION RAINFALL INTENSITIES

5 mins duration rainfall intensities for ARIs of 20 and 100 years for any place in Australia may be determined from the following Figures:

- (a) Figure E1: Location of areas.
- (b) Figures E2, E4, E6, E8, E10 and E12: Area numbers 1 to 6, respectively—Rainfall intensities for an ARI of 20 years.
- (c) Figures E3, E5, E7, E9, E11 and E13: Area numbers 1 to 6, respectively—Rainfall intensities for an ARI of 100 years.

The Figures are marked with isopleths of rainfall intensity (lines of equal rainfall intensity).

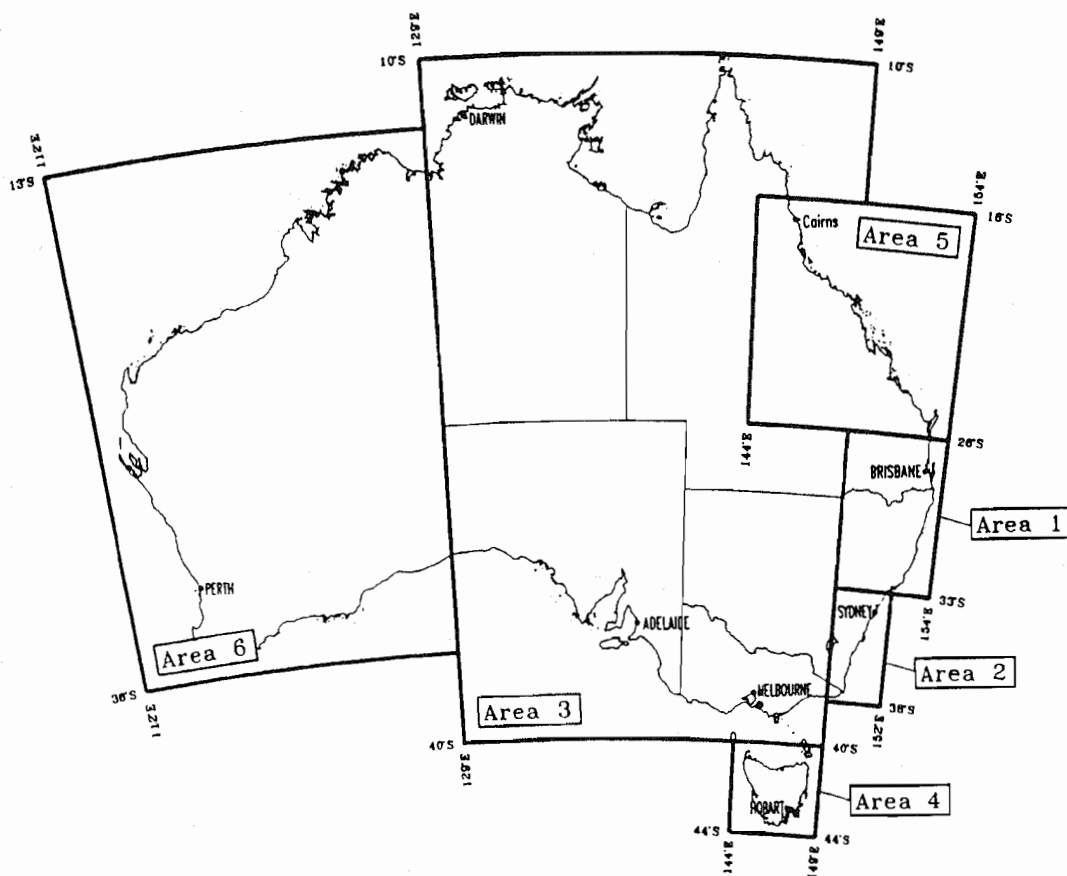

Prepared by: Hydrometeorological Advisory Service, Melbourne,
© Commonwealth of Australia, Bureau of Meteorology, 1991

FIGURE E1 LOCATION OF AREAS

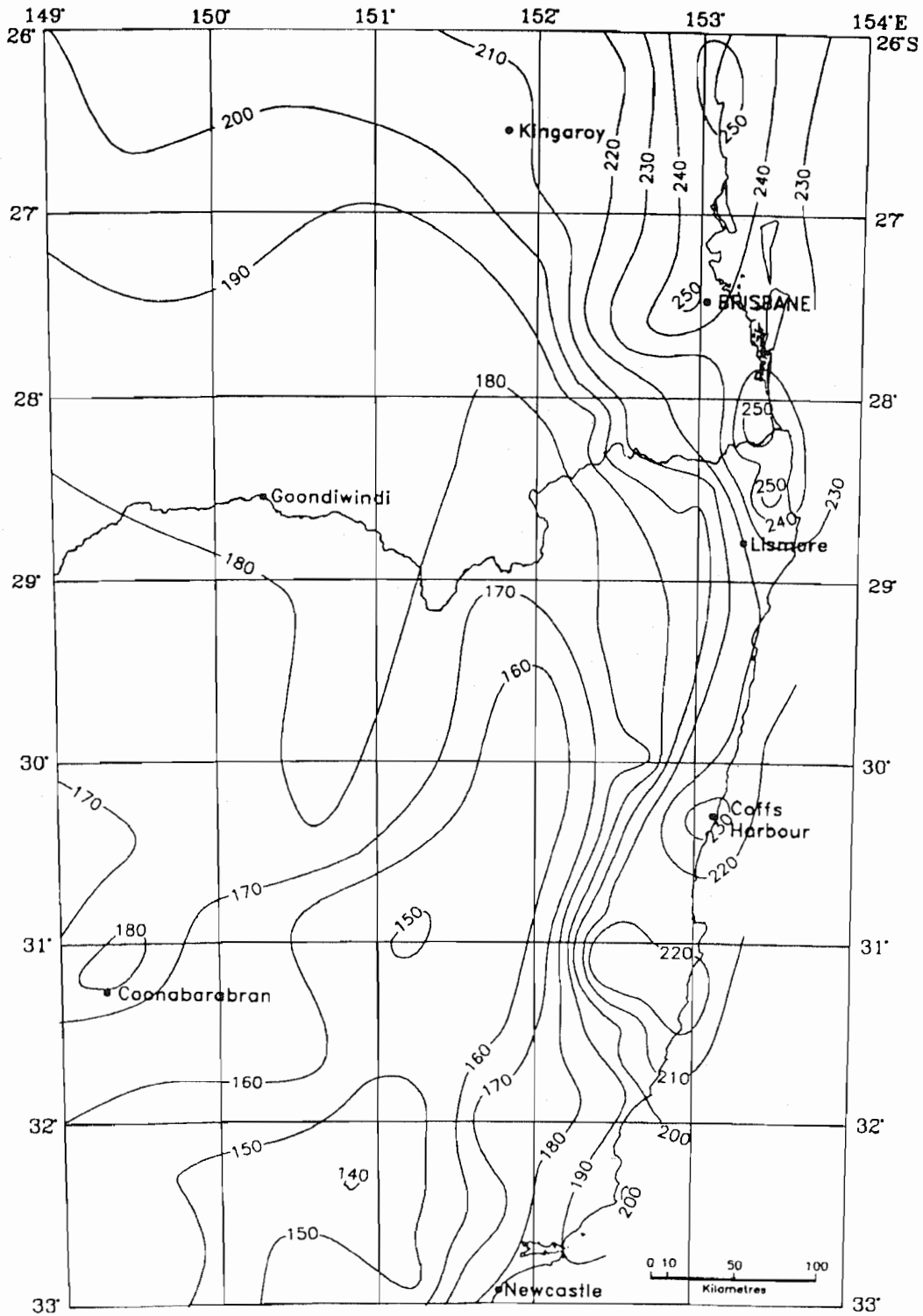

Prepared from CDIRS by: Hydrometeorological Advisory Service, Melbourne
© Commonwealth of Australia, Bureau of Meteorology, 1991

FIGURE E2 AREA 1—RAINFALL INTENSITIES (mm/h)—5 MIN—ARI 20 YEARS

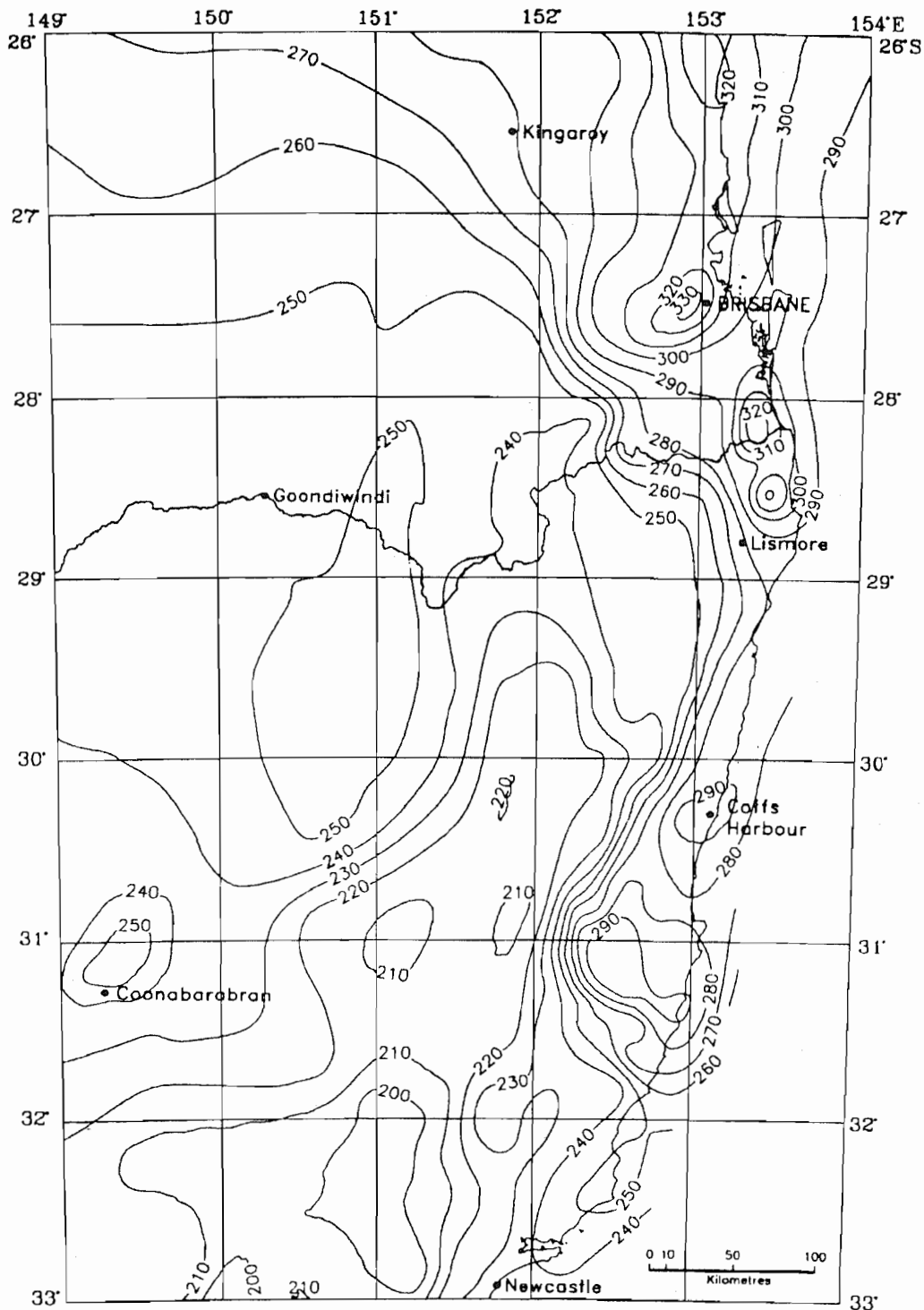

Prepared from CDIRS by: Hydrometeorological Advisory Service, Melbourne
© Commonwealth of Australia, Bureau of Meteorology, 1991

FIGURE E3 AREA 1—RAINFALL INTENSITIES (mm/h)—5 MIN—ARI 100 YEARS

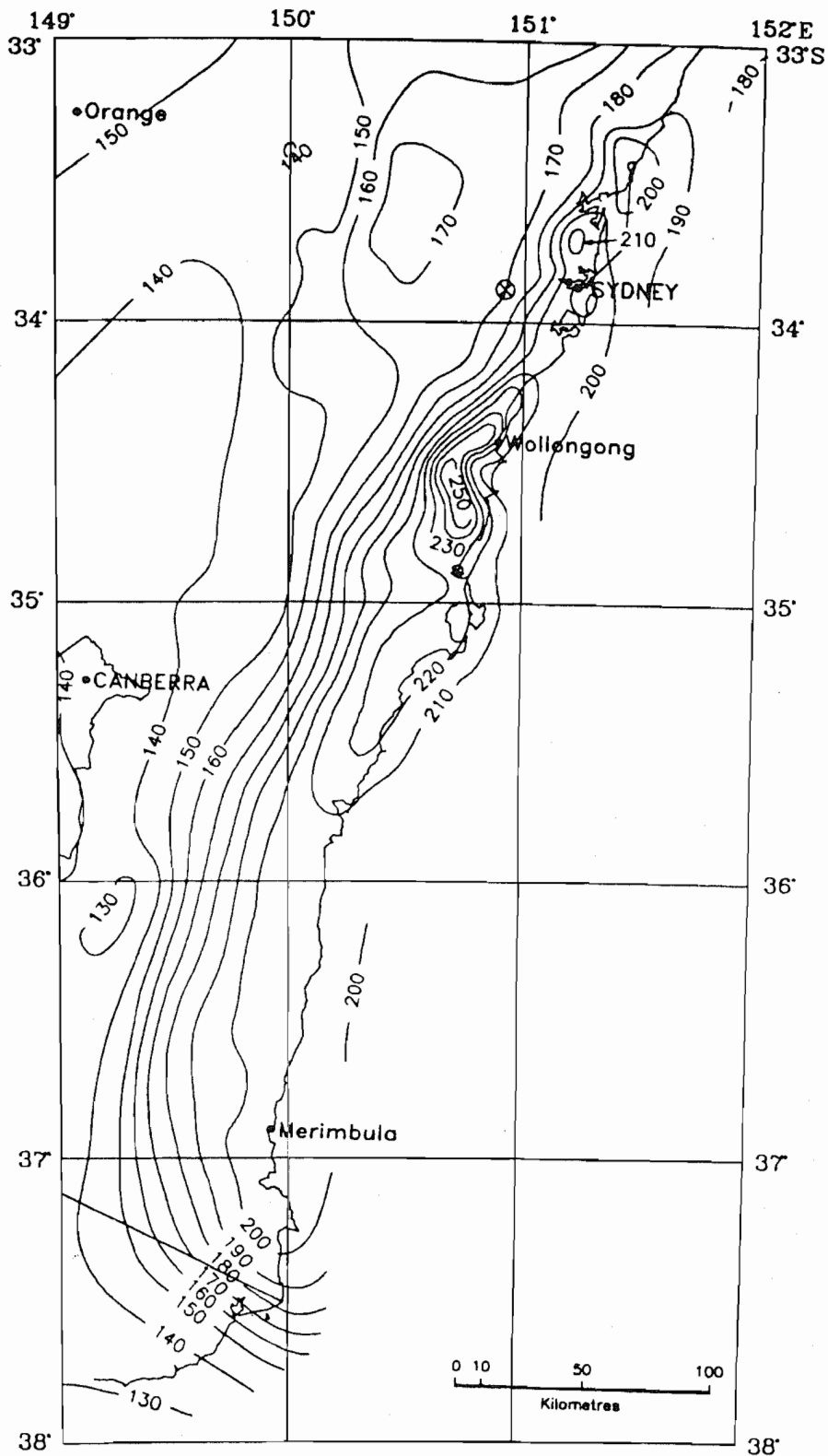

Prepared from CDIRS by: Hydrometeorological Advisory Service, Melbourne
© Commonwealth of Australia, Bureau of Meteorology, 1991

FIGURE E4 AREA 2—RAINFALL INTENSITIES (mm/h)—5 MIN—ARI 20 YEARS

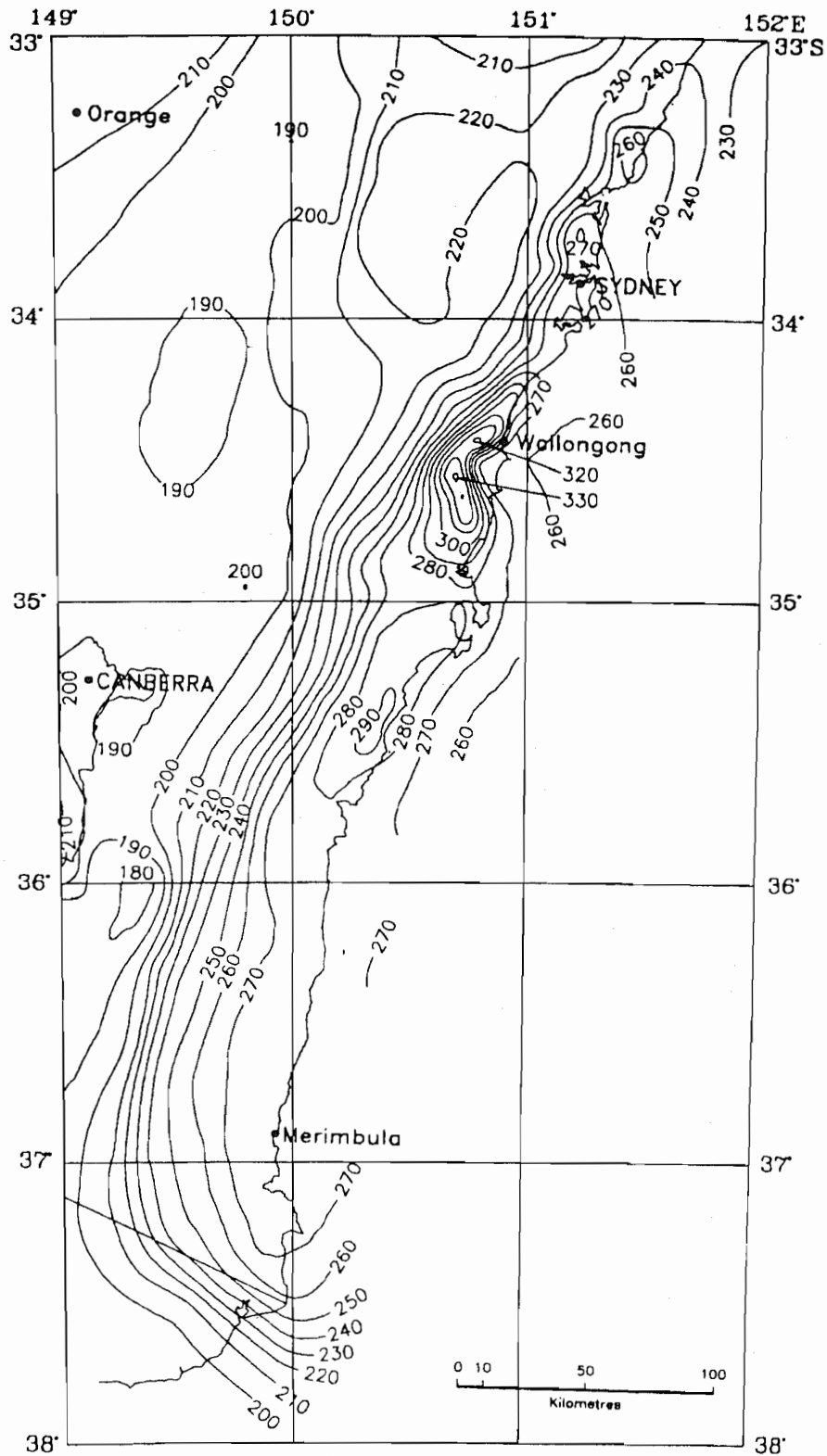

Prepared from CDIRS by: Hydrometeorological Advisory Service, Melbourne
© Commonwealth of Australia, Bureau of Meteorology, 1991

FIGURE E5 AREA 2—RAINFALL INTENSITIES (mm/h)—5 MIN—ARI 100 YEARS

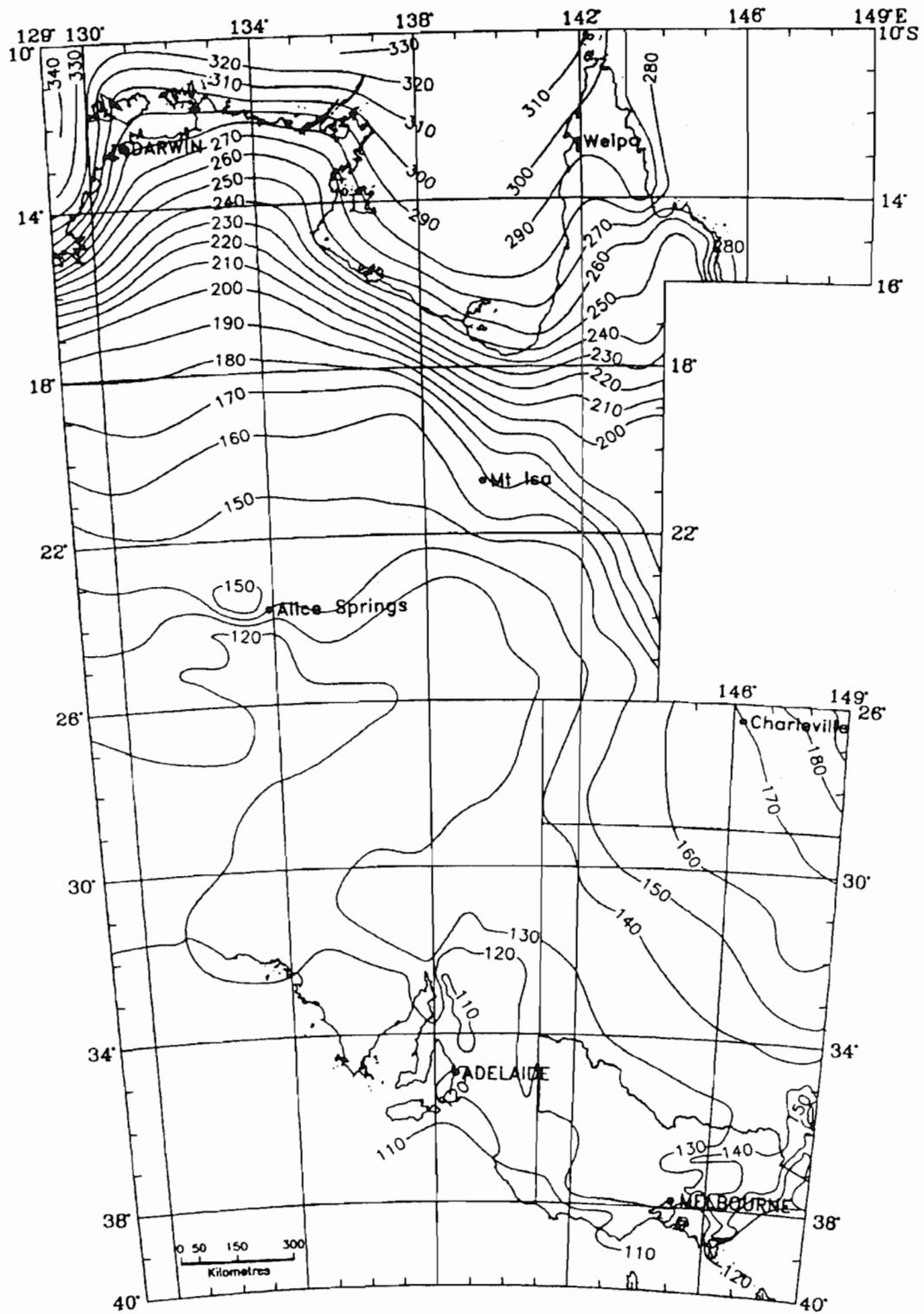

Prepared from CDIRS by: Hydrometeorological Advisory Service, Melbourne
© Commonwealth of Australia, Bureau of Meteorology, 1991

FIGURE E6 AREA 3—RAINFALL INTENSITIES (mm/h)—5 MIN—ARI 20 YEARS

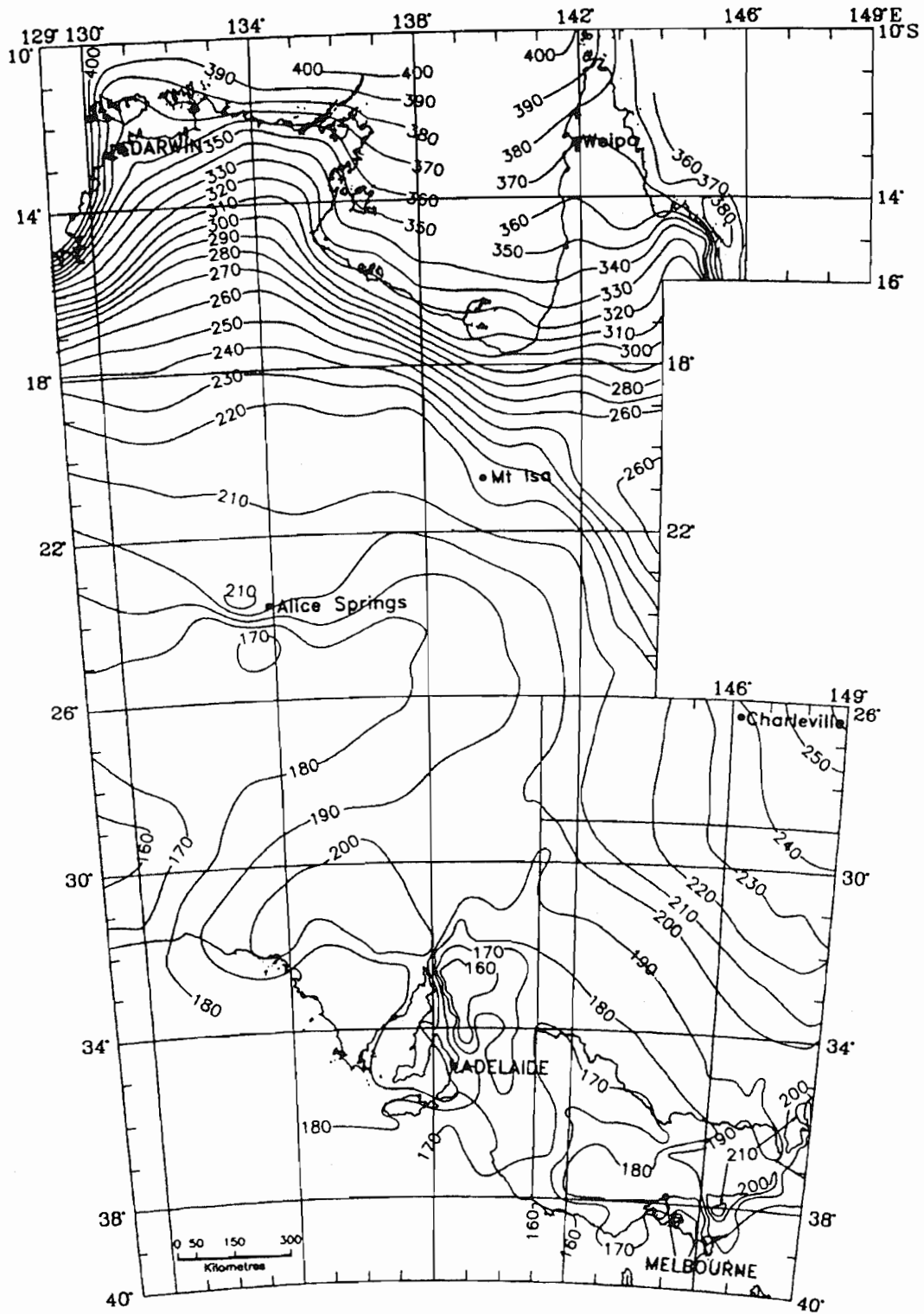

Prepared from CDIRS by: Hydrometeorological Advisory Service, Melbourne
© Commonwealth of Australia, Bureau of Meteorology, 1991

FIGURE E7 AREA 3—RAINFALL INTENSITIES (mm/h)—5 MIN—ARI 100 YEARS

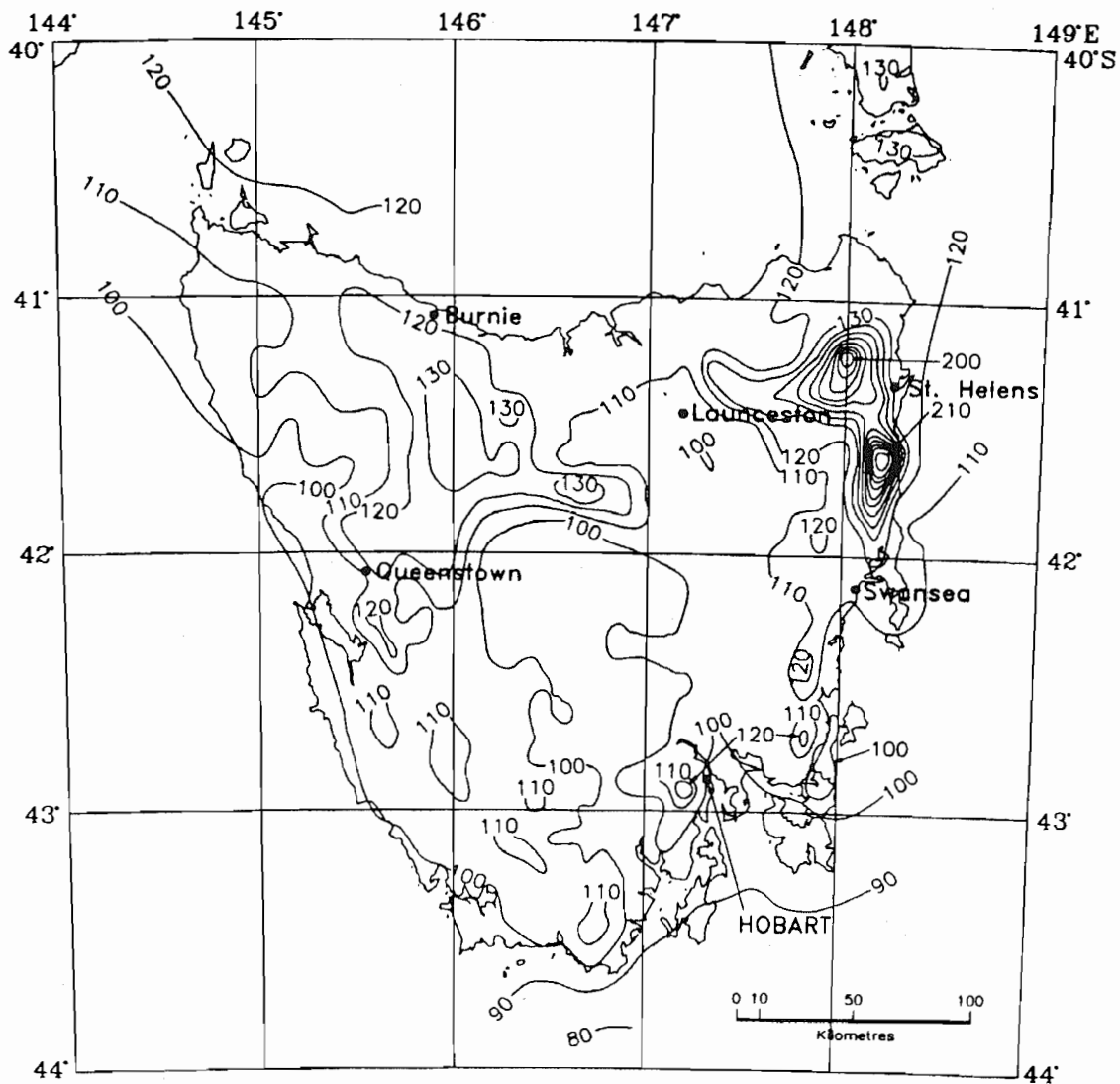

Prepared from CDIRS by: Hydrometeorological Advisory Service, Melbourne
© Commonwealth of Australia, Bureau of Meteorology, 1991

FIGURE E8 AREA 4—RAINFALL INTENSITIES (mm/h)—5 MIN—ARI 20 YEARS

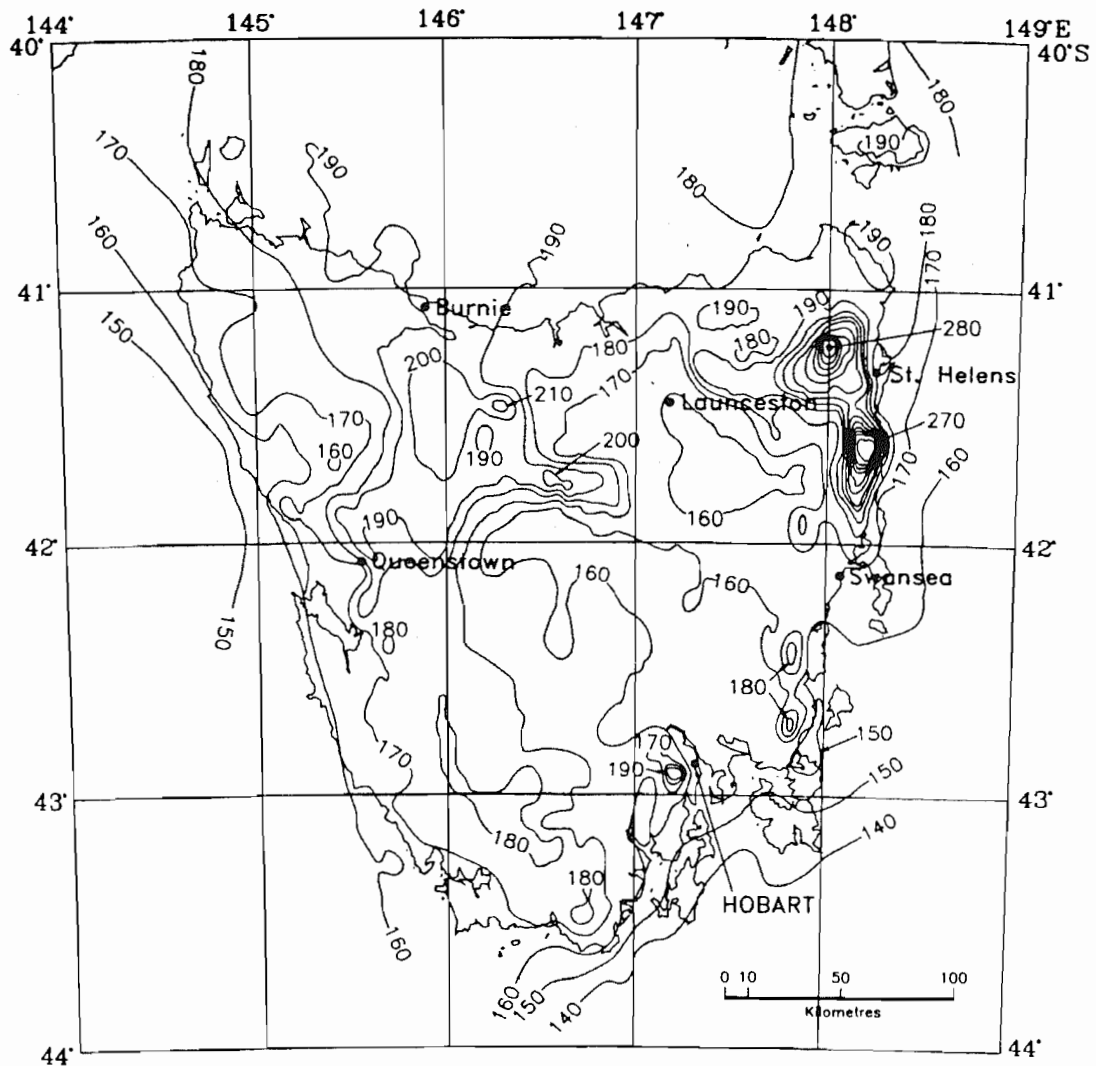

Prepared from CDIRS by: Hydrometeorological Advisory Service, Melbourne
 © Commonwealth of Australia, Bureau of Meteorology, 1991

FIGURE E9 AREA 4—RAINFALL INTENSITIES (mm/h)—5 MIN—ARI 100 YEARS

A1

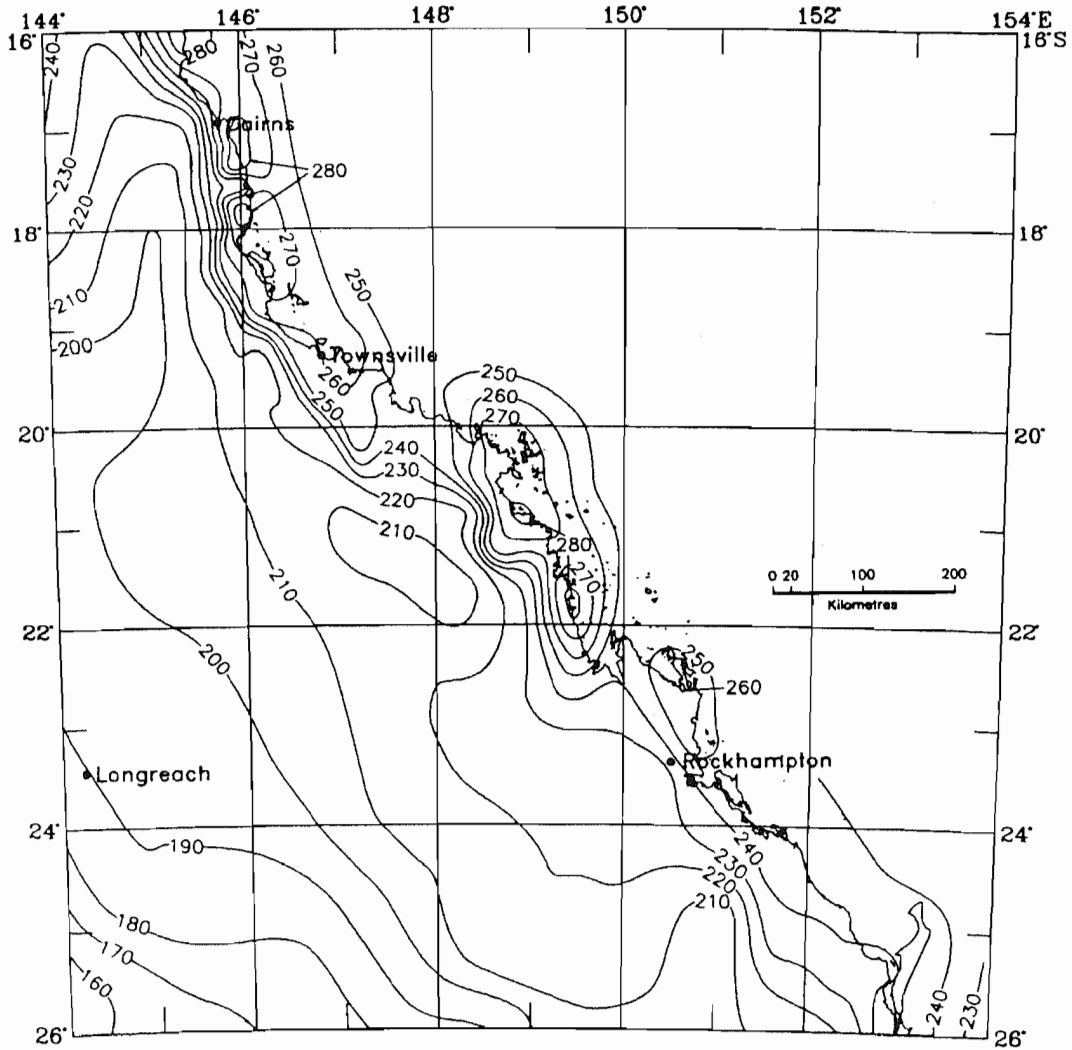

Prepared from CDIRS by: Hydrometeorological Advisory Service, Melbourne
© Commonwealth of Australia, Bureau of Meteorology, 1991

FIGURE E10 AREA 5—RAINFALL INTENSITIES (mm/h)—5 MIN—ARI 20 YEARS

A1

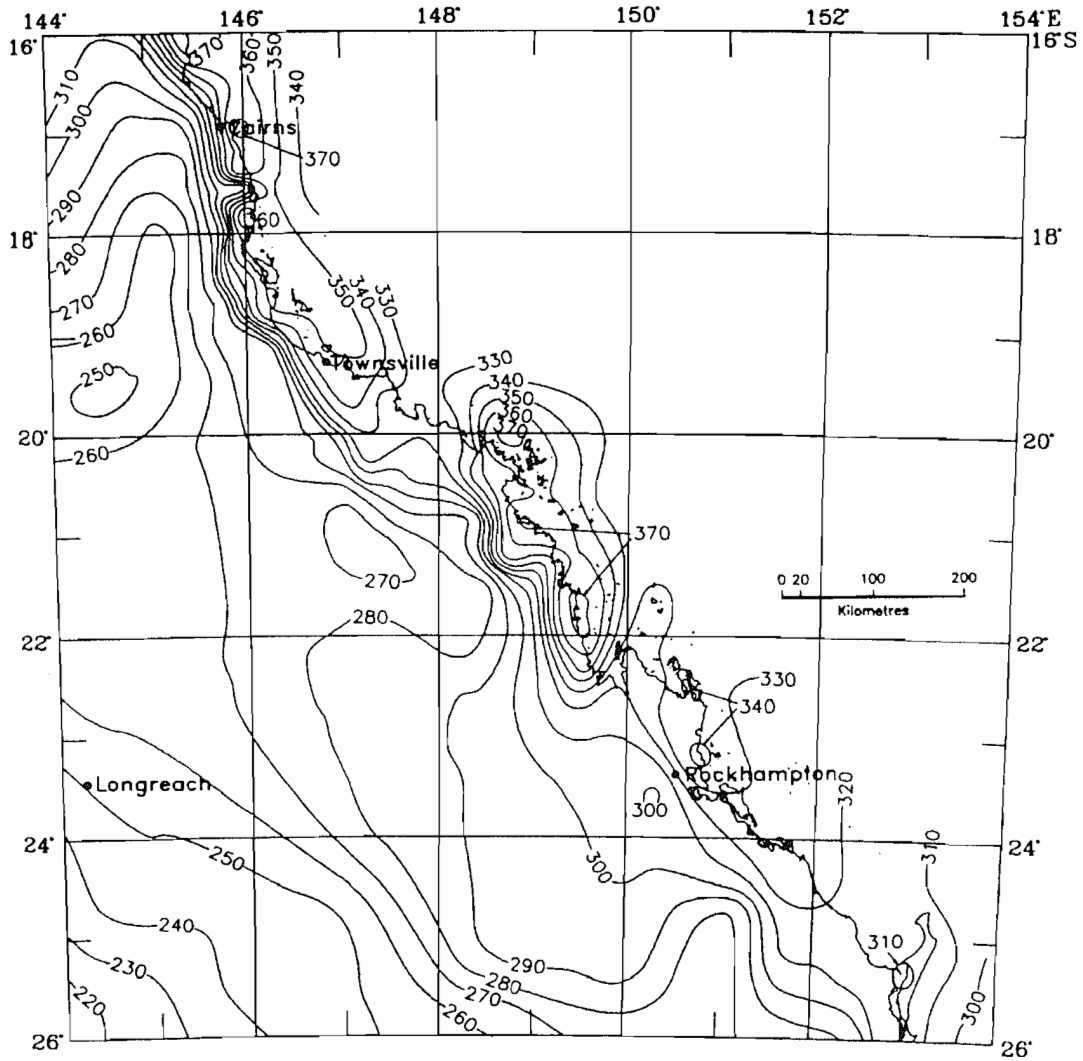

Prepared from CDIRS by: Hydrometeorological Advisory Service, Melbourne
© Commonwealth of Australia, Bureau of Meteorology, 1991

FIGURE E11 AREA 5—RAINFALL INTENSITIES (mm/h)—5 MIN—ARI 100 YEARS

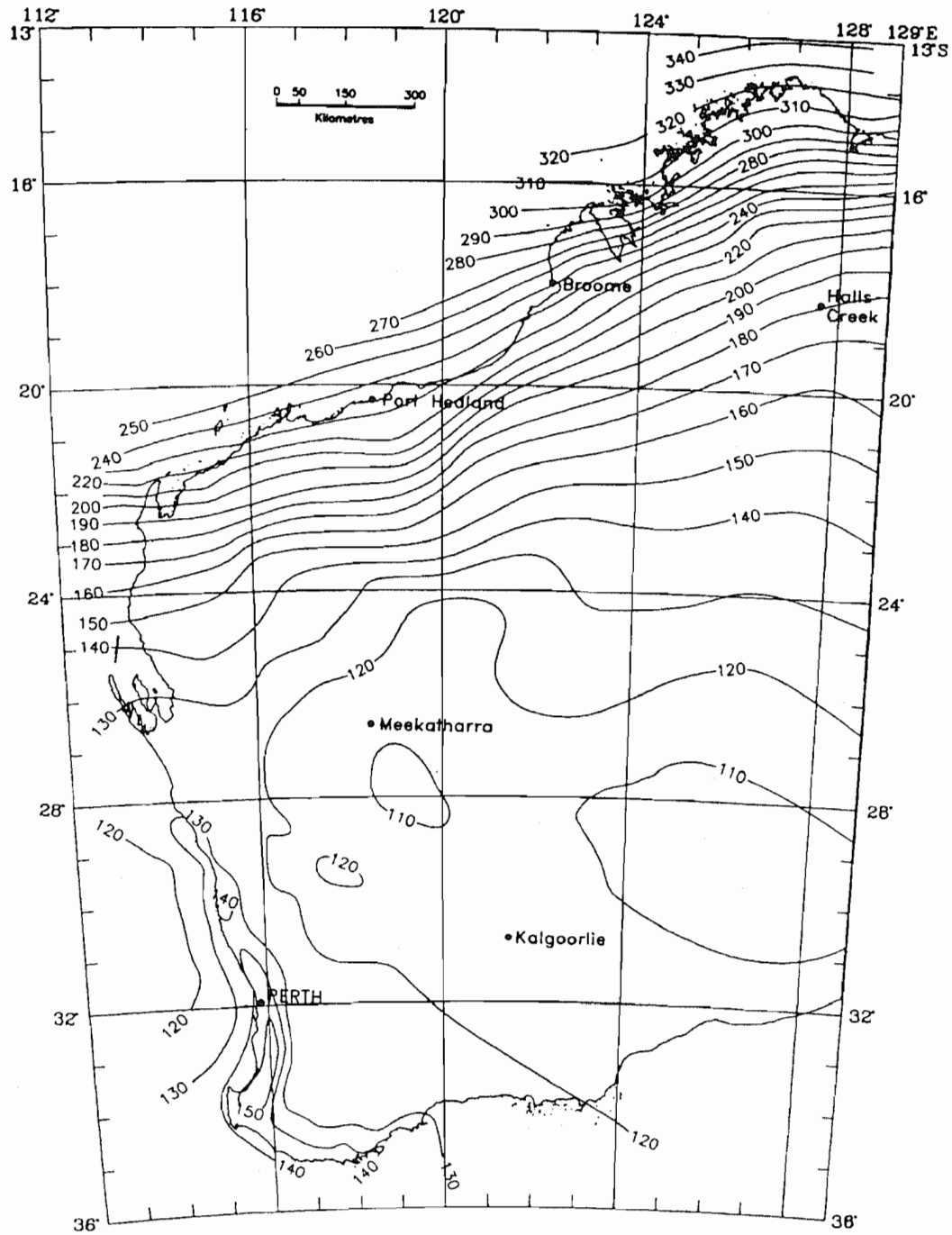

Prepared from CDIRS by: Hydrometeorological Advisory Service, Melbourne
© Commonwealth of Australia, Bureau of Meteorology, 1991

FIGURE E12 AREA 6—RAINFALL INTENSITIES (mm/h)—5 MIN—ARI 20 YEARS

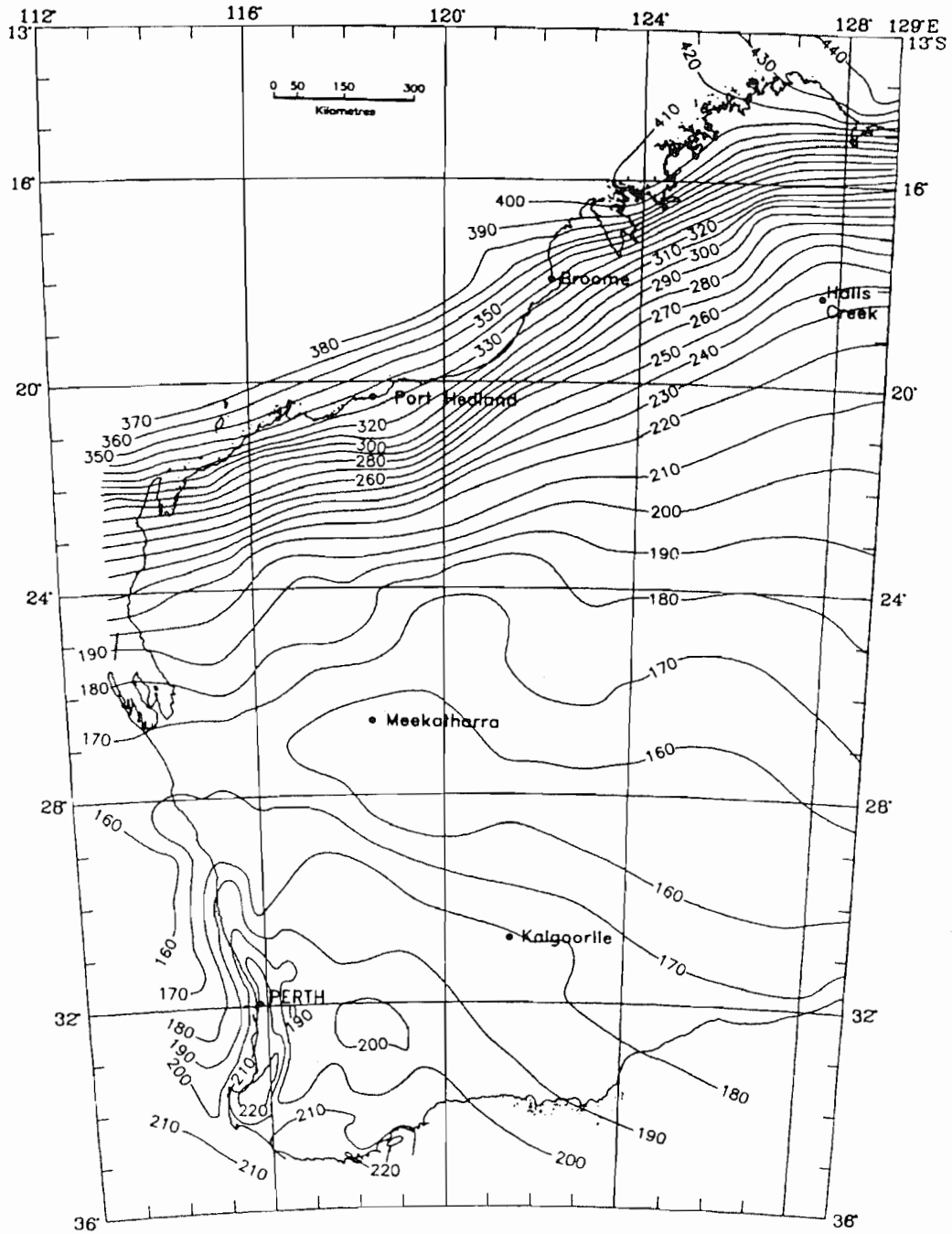

Prepared from CDIRS by: Hydrometeorological Advisory Service, Melbourne
© Commonwealth of Australia, Bureau of Meteorology, 1991

FIGURE E13 AREA 6—RAINFALL INTENSITIES (mm/h)—5 MIN—ARI 100 YEARS

APPENDIX F
RAINFALL INTENSITIES FOR NEW ZEALAND—10 MIN DURATION
(Normative)

F1 SCOPE

This Appendix gives 10 min duration rainfall intensities for any place in New Zealand, based on the Building Industry Authority data, used for the sizing of—

- (a) Rainwater goods (see Clause 3.3.5.2); and
- (b) Surface water drainage systems (see Clause 5.4.5(b)).

F2 10 MINUTES DURATION RAINFALL INTENSITIES

Rainfall intensities of 10 min duration for ARIs of 10 and 50 years for any place in New Zealand may be determined from the following Figures:

- (a) Figures F1 and F3—Rainfall intensities for an ARI of 10 years.
- (b) Figures F2 and F4—Rainfall intensities for an ARI of 50 years.

The figures are marked with isopleths of rainfall intensity (lines of equal rainfall intensity).

Rainfall intensities (mm/h): 10m 10y ARI

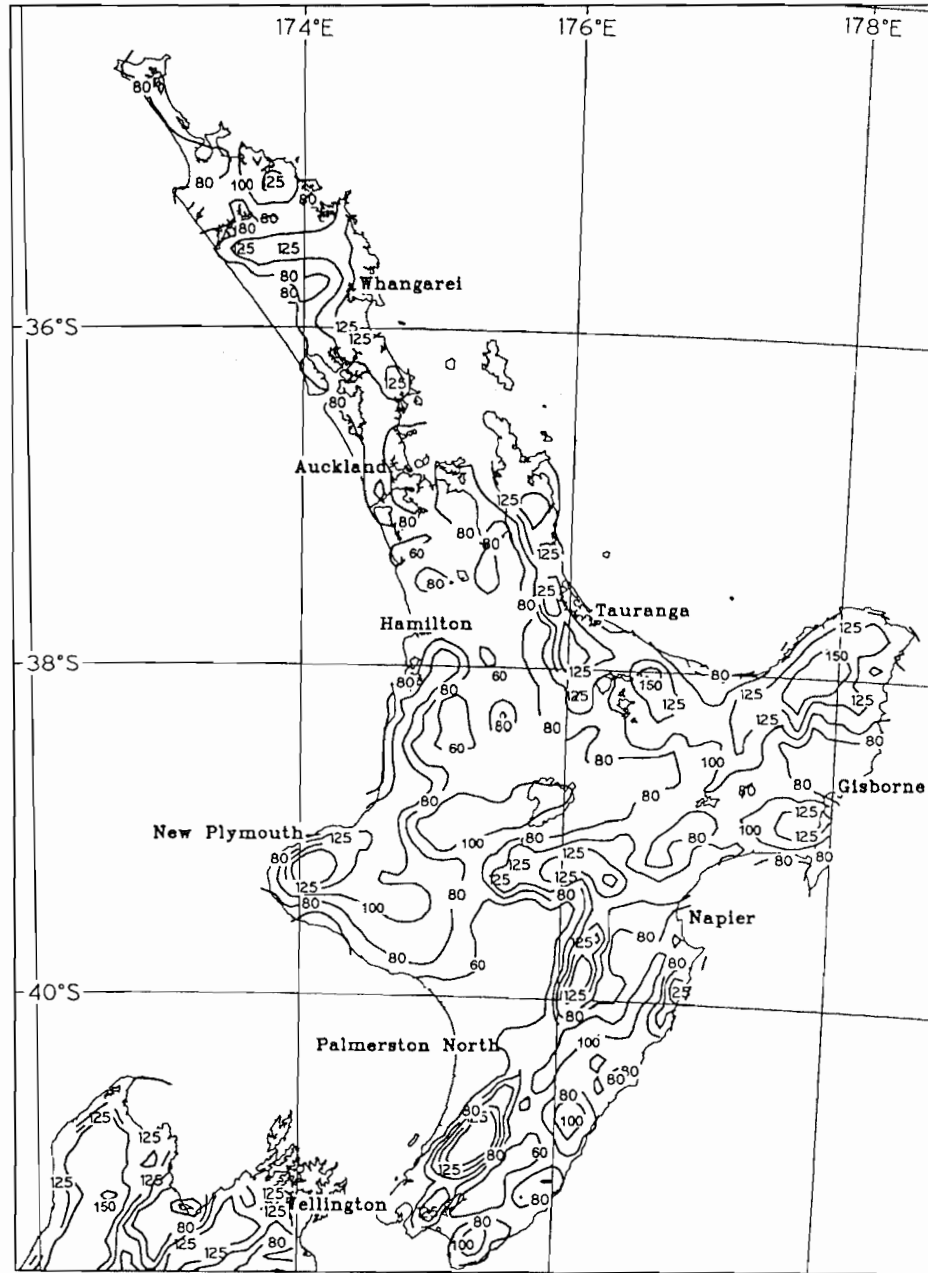

Prepared by: National Institute of Water and Atmospheric Research Ltd

FIGURE F1 NORTH ISLAND—RAINFALL INTENSITIES (mm/h)—10 MIN—ARI 10 YEARS

Rainfall intensities (mm/h): 10m 50y ARI

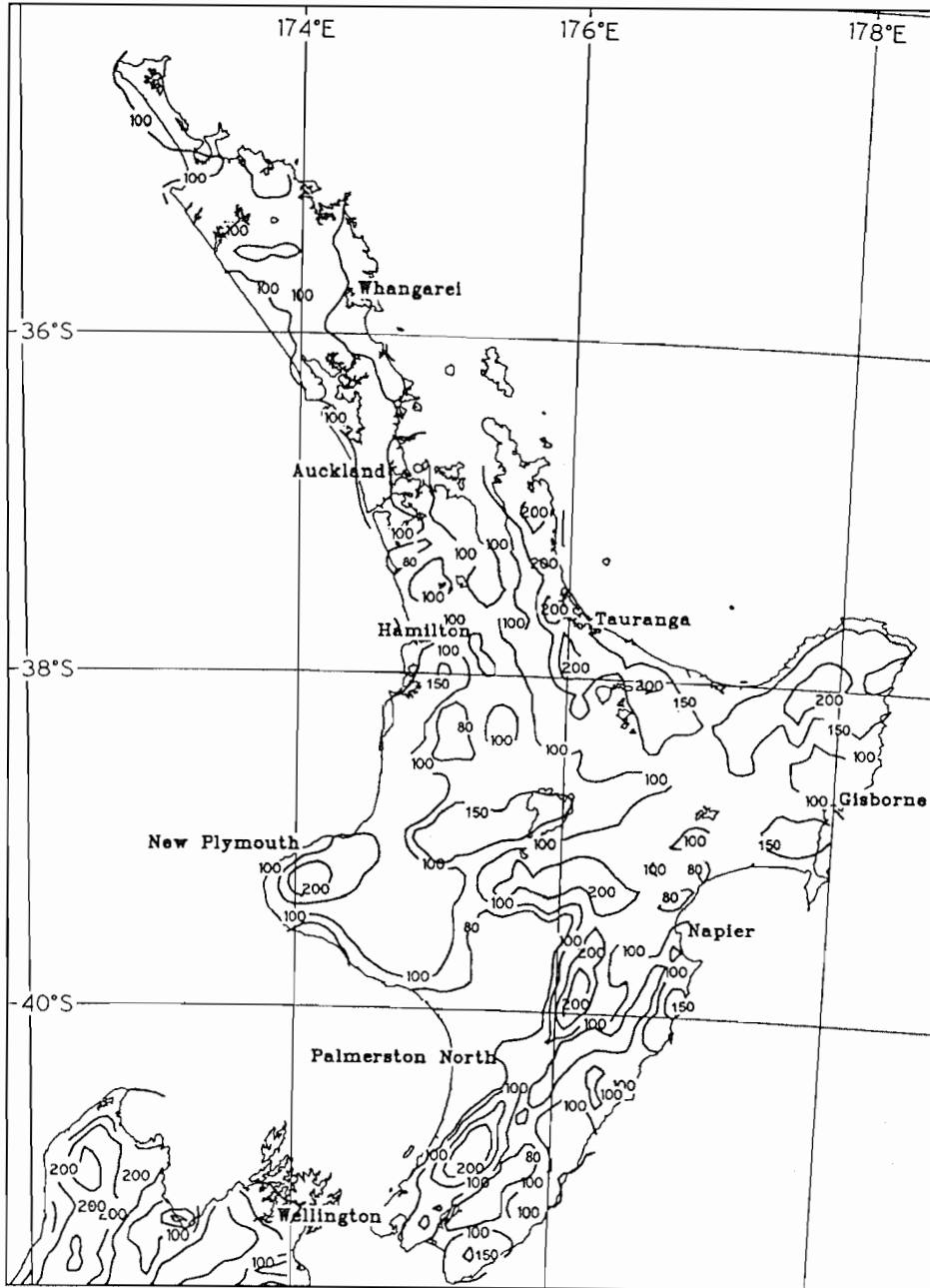

Prepared by: National Institute of Water and Atmospheric Research Ltd

FIGURE F2 NORTH ISLAND—RAINFALL INTENSITIES (mm/h)—10 MIN—ARI 50 YEARS

Rainfall intensities (mm/h): 10m 10y ARI

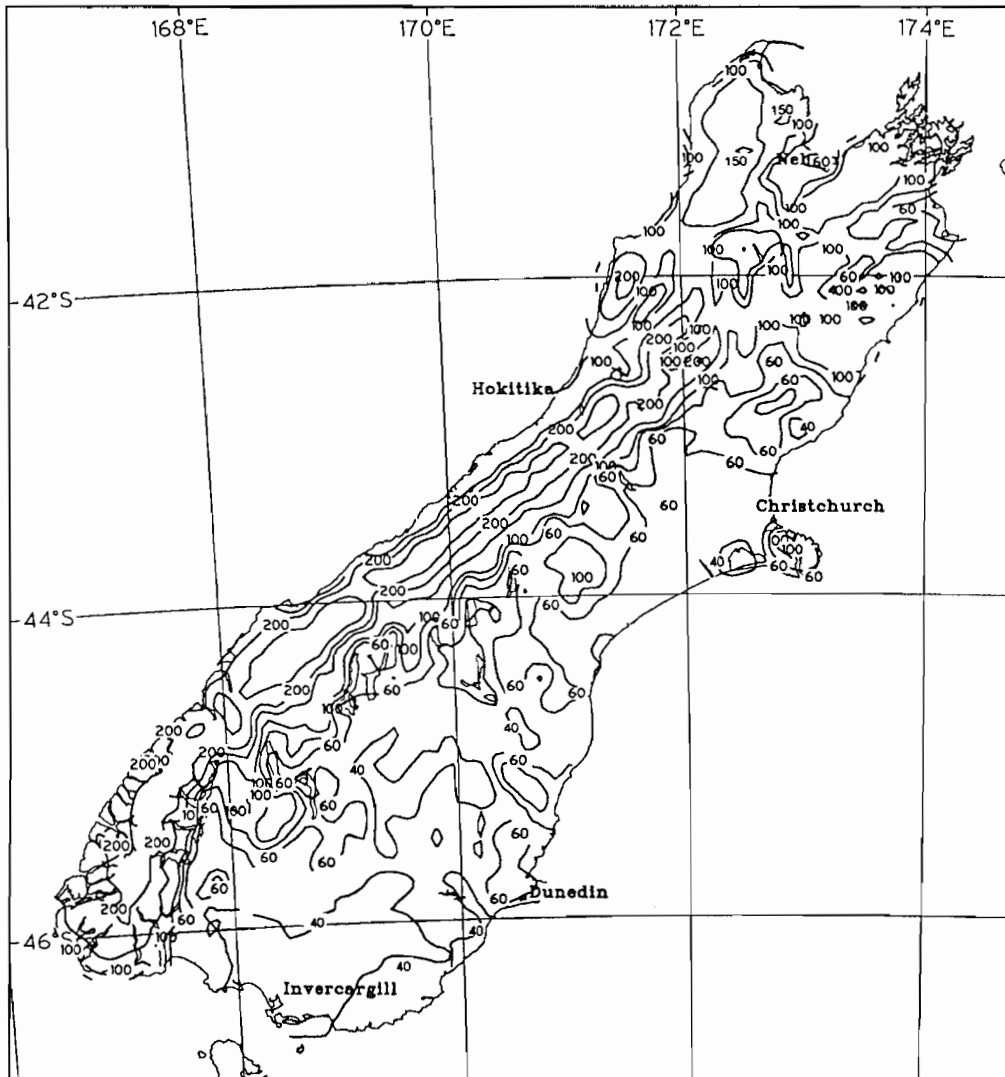

Prepared by: National Institute of Water and Atmospheric Research Ltd

FIGURE F3 SOUTH ISLAND—RAINFALL INTENSITIES (mm/h)—10 MIN—ARI 10 YEARS

Rainfall intensities (mm/h): 10m 50y ARI

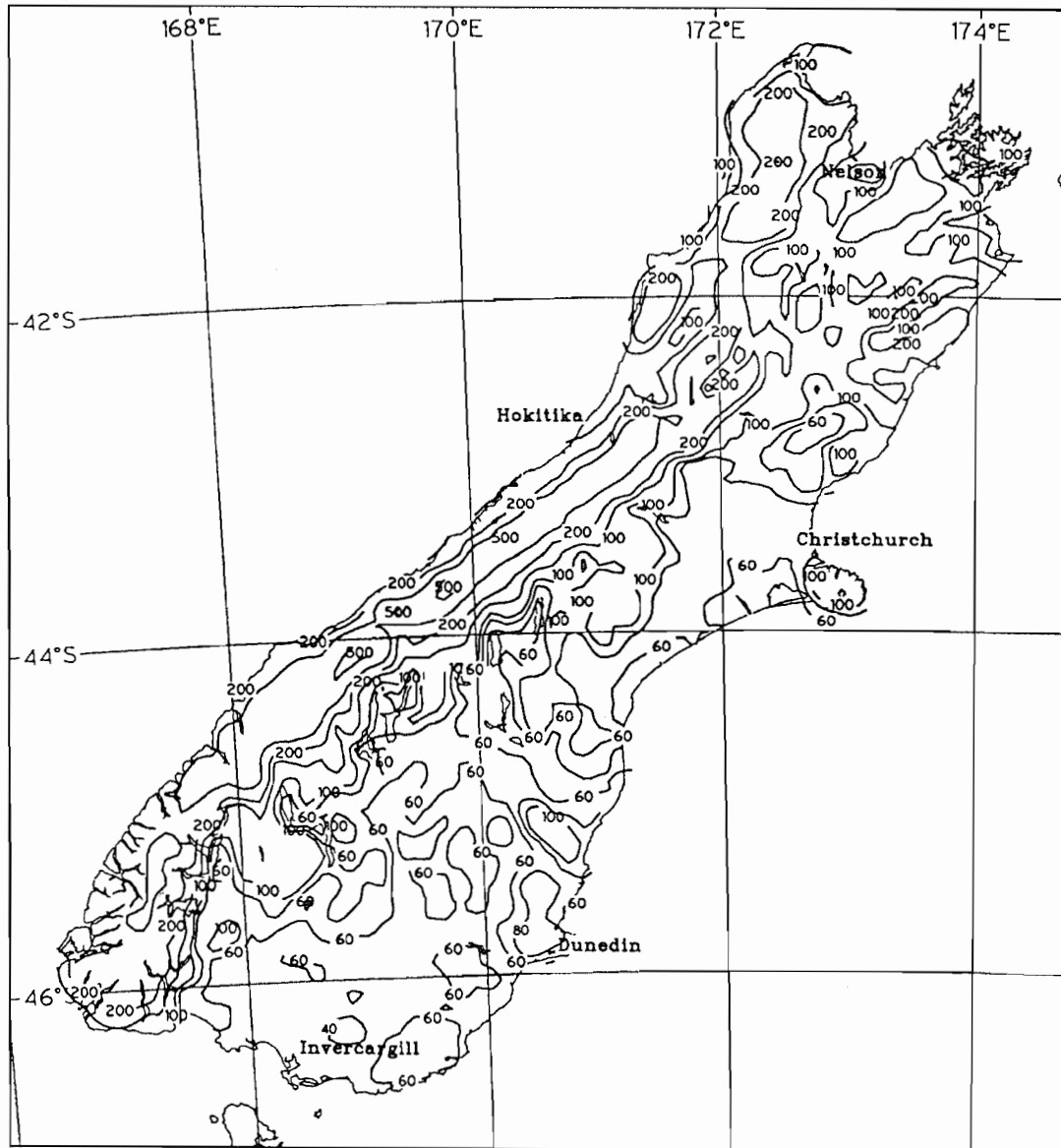

Prepared by: National Institute of Water and Atmospheric Research Ltd

FIGURE F4 SOUTH ISLAND—RAINFALL INTENSITIES (mm/h)—10 MIN—ARI 50 YEARS

APPENDIX G
EXAMPLES OF OVERFLOW MEASURES FOR EAVES GUTTERS
(Informative)

G1 SCOPE

This Appendix sets out examples of overflow measures for eaves gutters (see Clause 3.5).

G2 FULL LENGTH (CONTINUOUS) OVERFLOWS

Examples of acceptable full-length (continuous) overflows are as follows:

- (a) The front bead not less than the dimension h_f below the top of the fascia board as shown in Figure G1(a)—(weir flow over front of gutter).
- (b) The front bead not less than the dimension h_f below the top edge of the back of the gutter—(weir flow over front of gutter).
- (c) Flashing as shown in Figure G1(b) with the top edge of the flashing not less than h_f above the bead—(weir flow over front of gutter).
- (d) Combinations of Items (a), (b) or (c).
- (e) The top edge of the back of the gutter not less than h_f below the top of the fascia board as shown in Figure G1(c)—(weir flow over back of gutter).
- (f) For concealed eaves gutters the top edge of the fascia not less than h_f below the top of the back of the gutter, or integral flashing (tail) with the top edge of the flashing not less than h_f above the top of the fascia as shown in Figure G1(d)—(weir flow over front of gutter).

The h_f value shall be determined from Table G1 where the average flow per metre is determined from the total flow shown in Figure 3.5 divided by the length of the eaves gutter served by the catchment.

NOTE: Blockages can and do occur anywhere along an eaves gutter causing overtopping that would not be affected by an overflow device located at the outlet of an eaves gutter, e.g. rainhead (see Figure 3.7(a)). The overflow devices given in Paragraph G2 are located along an eaves gutter so that any overtopping is unlikely to cause monetary loss or property damage including damage to contents of a building. The ARIs for eaves gutters given in Table 3.1 assume the provision of appropriate overflow measures.

G3 SPECIFICALLY LOCATED OVERFLOWS

Examples of specifically located overflows are holes and weirs.

TABLE G1
MINIMUM h_f VALUES

| Gutter slope | Average inflow per metre of gutter (L/s per m) | | | | |
|----------------|---|-----|-----|-----|-----|
| | 0.2 | 0.4 | 0.6 | 0.8 | 1.0 |
| Level gutter | 18 | 20 | 22 | 23 | 25 |
| Sloping gutter | 12 | 14 | 16 | 17 | 19 |
| | Minimum h_f (mm) | | | | |

NOTE: Minimum h_f is based on $^{100}I_5$ for Australia and $^{50}I_{10}$ for New Zealand. Table G1 includes an allowance for water surface undulations and construction tolerances of 19 mm for level gutters and 13 mm for sloping gutters. Available research suggests that surface undulations may be limited to the range 5 mm to 8 mm, provided that the discharge from metal cladding for all roof slopes is directed downwards by turning down the outside edge. Figure G2 illustrates the effect.

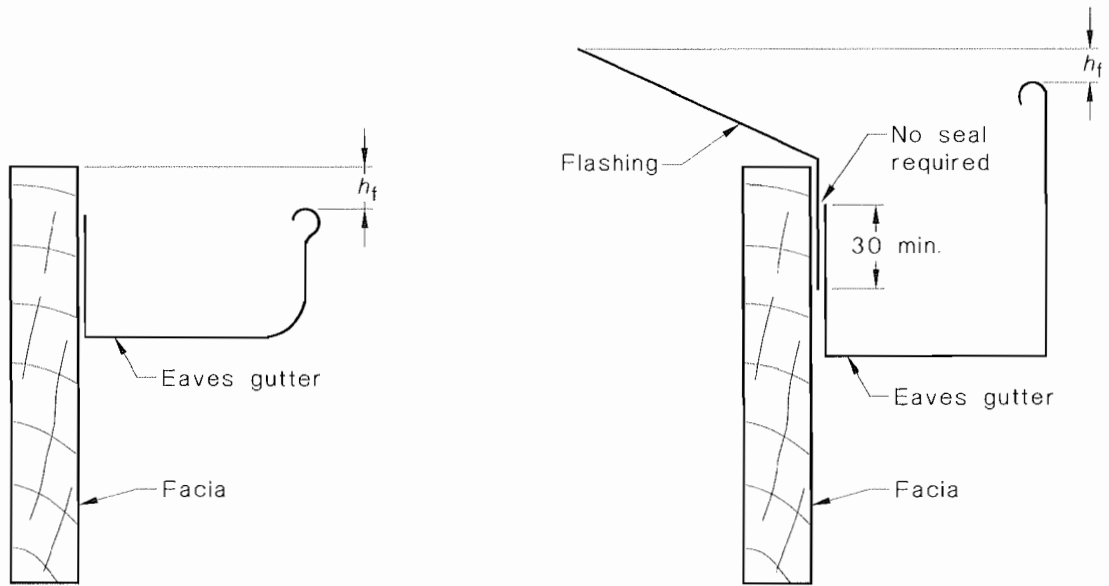

(a) Eaves gutter with low front

(b) Eaves gutter with high front and rear flashing

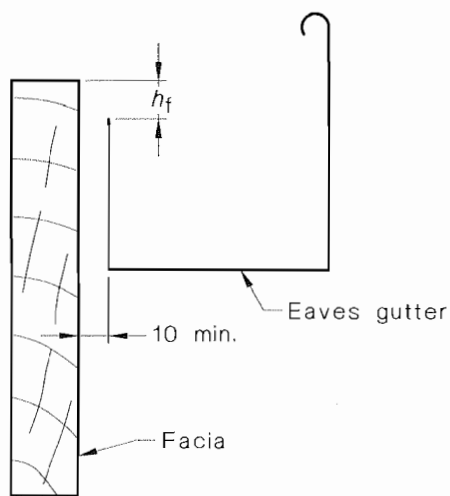

(c) Eaves gutter with high front and min. 10 mm gap to fascia

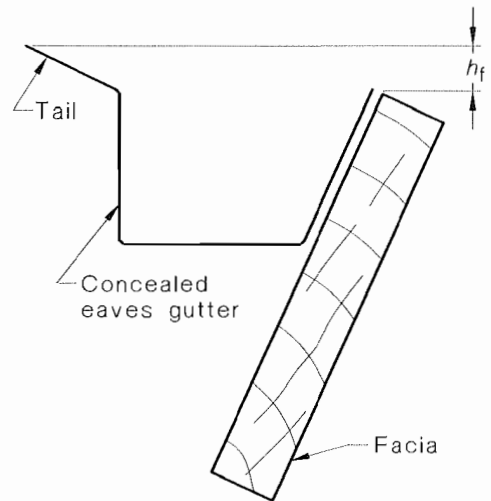

(d) Concealed eaves gutter with tail

FIGURE G1 EAVES GUTTER OVERFLOW METHODS

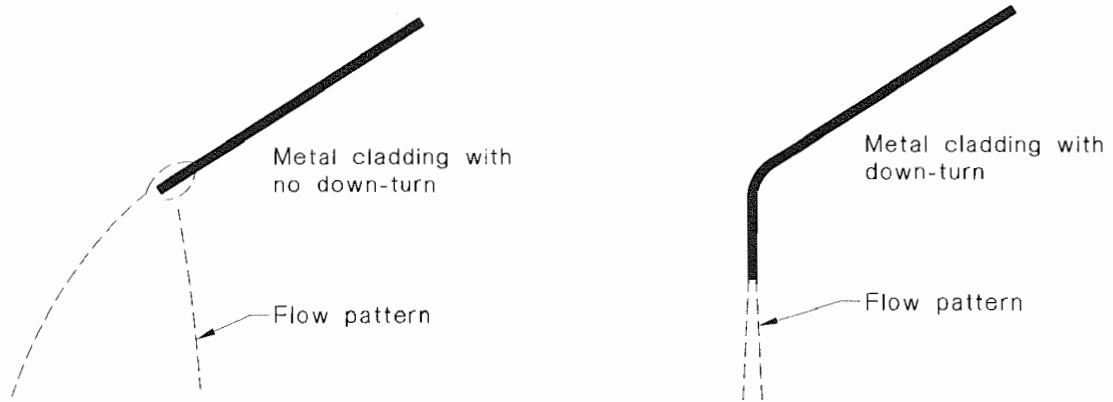

FIGURE G2 ILLUSTRATION OF FLOW PATTERNS FOR METAL ROOF CLADDING

APPENDIX H
GENERAL METHOD FOR DESIGN OF EAVES GUTTER SYSTEMS—
EXAMPLE

(Informative)

H1 SCOPE

This Appendix sets out an example that illustrates the application of the general method for design of solutions for eaves gutters and associated vertical downpipes (see Clause 3.5).

The calculations are presented in an explanatory form to assist first and occasional users. The adopted order of accuracy in the examples is consistent with the accuracy of the assumptions on which they are based.

NOTE: Appendix D gives guidelines for the determination for any place in—

- (a) Australia, for rainfall intensities of 5 min duration and ARIs of 20 and 100 years; and
- (b) New Zealand, for rainfall intensities of 10 min duration and ARIs of 10 and 50 years.

H2 EXAMPLE

H2.1 Problem

A house as shown in Figure H1 is to be constructed at Bathurst in New South Wales (see Figure E4). Determine the layout and size of the external eaves gutters and associated vertical downpipes that are to discharge to the surface water drainage system for the following cases:

Case 1: eaves gutter gradients of 1:500 and steeper.

Case 2: eaves gutter gradients flatter than 1:500.

To assist the understanding of this example the application of Figures 3.5(A) and E4 is shown in Figure H2.

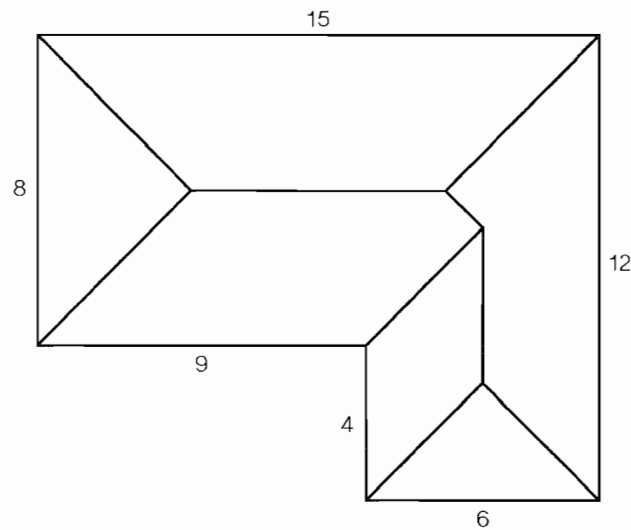

NOTES:

- 1 Dimensions include width of eaves gutter.
- 2 Pitch of roof 24° (1:2.3).

DIMENSIONS IN METRES

FIGURE H1 HOUSE PLAN

H2.2 Case 1—Sloping eaves gutter**H2.2.1 Calculation**

The calculation below illustrates the application of the procedure shown in Figure 3.4. Each step designation (for example (a), (b), (c) and so on) has a corresponding letter in the flow chart.

| CASE 1 | |
|--------|---|
| (a) | From Table 3.1, select 20 years ARI for Australia and 10 years ARI for New Zealand |
| (b) | In Australia the design rainfall intensity for external eaves gutters and associated vertical downpipes will have a 5 min duration. The value for Bathurst in New South Wales is determined from Table E1 and Figure E4 and is 145 mm/h. The application of Figure E4 for this example is shown in Figure H2. |
| (c) | By physical observations, measurements or plans of the house, record, as shown on Figure H1— <ol style="list-style-type: none"> (i) overall dimensions that include an allowance for the widths of the eaves gutters; (ii) pitch (slope) of the roof; and (iii) layout of the ridges and valleys |
| (d) | Determine for the roof of the house: <ol style="list-style-type: none"> (i) from Figure H1, the plan area (A_p) is 144 m²; and (ii) from Equation 3.4.3(2) and pitch of the roof, the catchment area (A_c) is 175 m². |
| (e) | Select gradients for the eaves gutters; Select 1:500 and steeper |
| (f) | Select eaves gutters from a manufacturer's technical data and note the effective cross-sectional areas (A_e); A_e is 7300 mm ² (square fascia) |

| CASE 1 | |
|--------|---|
| (g) | <p>Determine, for the selected size of eaves gutter; using Figure 3.5(A) the maximum size of the catchment of the roof per vertical downpipe.</p> <p>Note: This determination is illustrated in Figure H2</p> <p>The maximum catchment area A_{cdp} of roof per vertical downpipe is 51 m^2</p> |
| (h) | <p>Determine for the selected sizes of eaves gutter (see Step (f)) the minimum number of vertical downpipes from A_c/A_{cdp}</p> $\frac{175}{51} = 3.4$ <p>adopt the next higher whole number, which is 4</p> |
| (i) | <p>Select locations, as shown in Figure H3, for the minimum of four downpipes</p> <p>(i) where practical, the sub-catchments have about the same area; and</p> <p>(ii) a high point is located at an outlet to a valley gutter.</p> <p>NOTE: A_h and A_c for the selected sub-catchments are tabulated in Table H1</p> |
| (j) | <p>For this example the catchment area for each sub-catchment (A_{s-c}) is not greater than A_{cdp}. If the area of one or more catchment areas is greater than the A_{cdp} then proceed in accordance with one or more of the following:</p> <p>(i) Increase the number of vertical downpipes and repeat Steps (g) to (i).</p> <p>(ii) Re-position vertical downpipes and repeat Step (i).</p> <p>(iii) Re-position high points and repeat Step (i).</p> <p>(iv) Increase the size of the eaves gutter, i.e., larger A_c, and repeat Steps (f) to (i).</p> |
| (k) | <p>From Table 3.3 the alternative sizes of the vertical downpipes for the selected gradients (see Step (e)) and sizes (see Step (f)) of eaves gutters are 100 mm diameter or 100 mm \times 75 mm.</p> |
| (l) | <p>Select overflow measures in accordance with Clause 3.5 if required. Comply with Paragraph G2(a). Determine the minimum height of fascia above the gutter overflow (h_f) to prevent water entering the building, as follows:</p> <p>Determine the maximum inflow per metre of eaves gutter from inspection of the plan. The maximum distance in plan from the eaves gutter to the ridge is 4 m. Hence the maximum catchment area per metre in plan is $4 \times 1 = 4 \text{ m}^2$. The value for inflow per metre to be used to not be less than $4 \times 145/3600 = 0.16 \text{ L/s per m}$. Select down pipe D from Table H1 (See note in Table H1).</p> <p>(i) For downpipe D—A_{sc} is 43 m^2 (see Table H1).</p> <p>(ii) Rainfall intensity is 145 mm/h (see Step (b)).</p> <p>(iii) From Figure 3.5A Total flow is 2.1 L/s</p> <p>(iv) Length of gutter is 9 m (see Table H1).</p> <p>(v) Average flow per metre of gutter = $2.1/9 = 0.23 \text{ L/s}$.</p> <p>(vi) From Table G1—(sloping gutter) minimum $h_f = 14 \text{ mm}$.</p> |

TABLE H1
SUB-CATCHMENT AREAS FOR DOWNPIPES

| Vertical downpipe | Sub-catchment | | |
|-------------------|---|---|--------------------------|
| | Case 1 | | |
| | Plan area (A_{hs-c}) m ² | Catchment area (A_{s-c}) m ² | Length of gutter m |
| A | 38.0 | 46 | 15.5 |
| B | 33.5 | 40 | 12.5 |
| C | 37.5 | 45 | 17 |
| D | 35.5 | 43 | 9 |
| Total | 144.0 | 174 | 54 |

NOTE: The sub-catchment for the vertical downpipe at D has the largest ratio of catchment to gutter length.

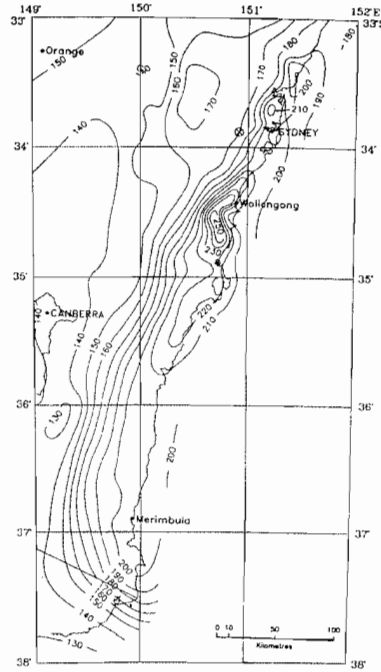

Prepared from CDIRS by: Hydrometeorological Advisory Service, Melbourne
 © Commonwealth of Australia, Bureau of Meteorology, 1991

FIGURE E4 AREA 2—RAINFALL INTENSITIES (mm/h)—5 MIN—ARI 20 YEARS

(a) Application of Figure E4

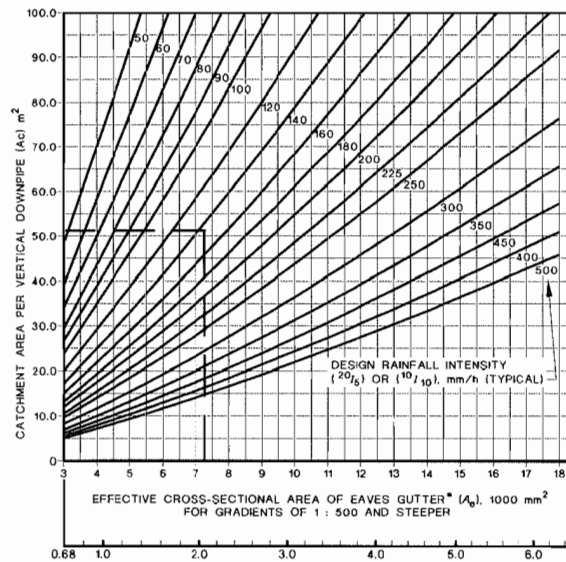

TOTAL FLOW IN EAVES GUTTER (L/s)

NOTES:

- 1 This graph assumes—
 - (a) an effective width to depth is a ratio of about 2:1;
 - (b) a gradient in the direction of flow of 1:500 or steeper;
 - (c) the least favourable positioning of the downpipe and bends within the gutter length;
 - (d) a cross-section or half round, quad, ogee or square; and
 - (e) the outlet to a vertical down pipe is located centrally in the sole of the eaves gutter.
- 2 The required eaves gutter discharge areas do not allow for loss of waterway due to internal brackets.

FIGURE H2 APPLICATION OF FIGURE 3.5(A)

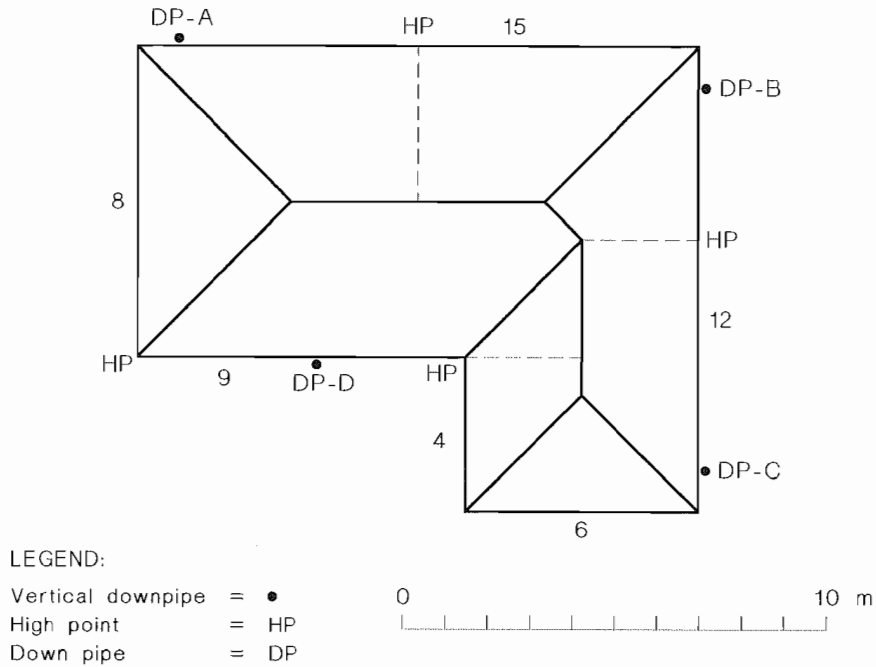

FIGURE H3 ROOF PLAN—CASE 1

H2.2.2 Solution

Adopt the following:

- (a) Roof plan as shown in Figure H3 with eaves gutter gradients for Case 1 of 1:500 and steeper.
- (b) Eaves gutters with an effective cross-sectional area of 7300 mm² (square fascia).
- (c) Vertical downpipes of 100 mm diameter or 100 mm × 75 mm rectangular.
- (d) Minimum height of fascia above gutter overflow is 14 mm.

H2.3 Case 2—Flat eaves gutter

H2.3.1 Calculation

The calculation below illustrates the application of the procedure shown in Figure 3.4. Each step designation (for example (a), (b), (c) and so on) has a corresponding letter in the flow chart.

| CASE 2 | |
|--------|--|
| (a) | From Table 3.1, select 20 years ARI for Australia and 10 years ARI for New Zealand |
| (b) | In Australia the design rainfall intensity for external eaves gutters and associated vertical downpipes will have a 5 mins duration. The value for Bathurst in New South Wales is determined from Table E1 and Figure E4 and is 145 mm/h. The application of Figure E4 for this example is shown in Figure H3. |
| (c) | By physical observations, measurements or plans of the house, record, as shown on Figure H1— (i) overall dimensions that include an allowance for the widths of the eaves gutters; (ii) pitch (slope) of the roof; and (iii) layout of the ridges and valleys |
| (d) | Determine for the roof of the house: (i) from Figure H1, the plan area (A_p) is 144 m ² ; and (ii) from Equation 3.4.3(2) and pitch of the roof, the catchment area (A_c) is 175 m ² . |
| (e) | Select gradients for the eaves gutters; Select flatter than 1:500. |

| CASE 2 | |
|---------------|--|
| (f) | Select eaves gutters from a manufacturers technical data and note the effective cross-sectional areas (A_c); A_c is 7300 mm ² (square fascia) |
| (g) | Determine, for the selected size of eaves gutter; using Figure 3.5(B), the maximum size of the catchment of the roof per vertical downpipe. Note: This determination is illustrated in Figure H4. The maximum catchment area A_{cdp} of roof per vertical downpipe is 36 m ² |
| (h) | Determine for the selected sizes of eaves gutter (see Step (f)) the minimum number of vertical downpipes from A_c/A_{cdp} $\frac{175}{36} = 4.9$ adopt the next higher whole number, which is 5. |
| (i) | Select locations, as shown in Figure H5, for the minimum of five downpipes. The layout in H4 requires precise positioning of the downpipes. In practice it is unlikely that this could be achieved because of windows, doors, and other features but nevertheless it demonstrates what happens if the same size eaves gutters are used for both Cases 1 and 2. With less precise positioning of the 5 downpipes, a larger eaves gutter would be required As there are no high points for flat eaves gutters to define the catchment areas for each downpipe and eaves gutter section, halve the total catchment area between adjacent downpipes to effectively create imaginary high points somewhere between the selected downpipes. Hence, if there are three downpipes in sequence numbered DP-1, DP-2 & DP-3, the catchment area of DP-2 is half the catchment area between DP-1 and DP-3, irrespective of the position of DP-2. A_h and A_c for the selected sub-catchments are tabulated in Table H2. |
| (j) | For this example the catchment area for each sub-catchment (A_{s-c}) is not greater than A_{cdp} . If the area of one or more catchment areas is greater than the A_{cdp} then increase the number of vertical downpipes and repeat Steps (g) to (i). |
| (k) | From Table 3.3 the alternative sizes of the vertical downpipes for the selected gradients (see Step (c)) and sizes (see Step (f)) of eaves gutters are 85 mm diameter or 100 mm × 50 mm. |
| (l) | Select overflow measures in accordance with Clause 3.5 if required. Comply with Paragraph G2(a). Determine the minimum height of fascia above the gutter overflow (h_f) to prevent water entering the building, as follows: Determine the maximum inflow per metre of eaves gutter from inspection of the plan. The maximum distance in plan from the eaves gutter to the ridge is 4 m. Hence the maximum catchment area per metre in plan is $4 \times 1 = 4 \text{ m}^2$. The value for inflow per metre to be used shall not be less than $4 \times 145/3600 = 0.16 \text{ L/s per m}$. Select downpipe E from Table H2 (See note in Table H2) (i) For downpipe E— A_{sc} is 36 m ² (see Table H2). (ii) Rainfall intensity is 145 mm/h (see Step (b)). (iii) From Figure 3.5B Total flow is 1.7 L/s (iv) Length of gutter is 9.5 m (see Table H2). (v) Average flow per metre of gutter = $1.7/9.5 = 0.18 \text{ L/s}$ (vi) From Table G1 —(level gutter) minimum $h_f = 18 \text{ mm}$. The minimum h_f values may not provide sufficient protection where valley gutters discharge to eaves gutters with zero slope. In such cases, it is recommended that h_f be increased in the vicinity of the valley gutters. The reason for this is that the valley gutter discharges into an eaves gutter that may already contain water. |

TABLE H2
SUB-CATCHMENT AREAS FOR DOWNPIPES

| Vertical downpipe | Sub-catchment Case 2 | | |
|----------------------|--|---|---------------------------|
| | Plan area ($A_{h_{s-c}}$) m ² | Catchment area (A_{s-c}) m ² | Length of Gutter* m |
| A | 29.5 | 36 | 11.5 |
| B | 29 | 35 | 10 |
| C | 26.8 | 32 | 13 |
| D | 29.2 | 35 | 10 |
| E | 29.5 | 36 | 9.5 |
| Total | 144 | 174 | 54 |

* Based on half the length between downpipes.

NOTE: The sub-catchment for the vertical downpipe at E has the largest for ratio of catchment to gutter length.

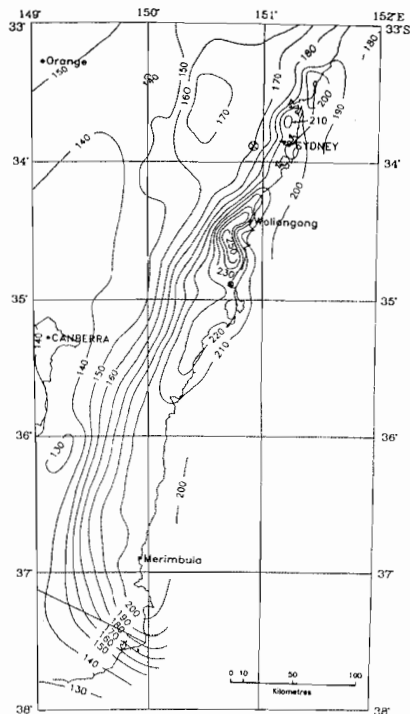

Prepared from CDIRS by: Hydrometeorological Advisory Service, Melbourne
 © Commonwealth of Australia, Bureau of Meteorology, 1991

FIGURE E4 AREA 2—RAINFALL INTENSITIES (mm/h)—5 MIN—ARI 20 YEARS

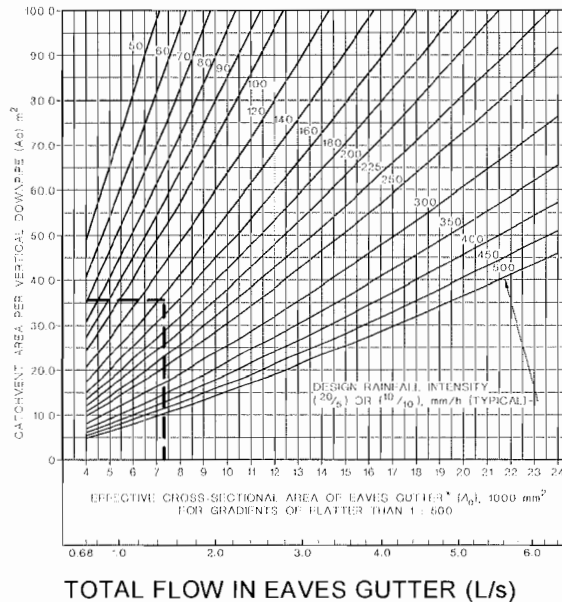

NOTES:

- 1 This graph assumes—
 - (a) an effective width to depth is a ratio of about 2:1;
 - (b) a gradient in the direction of flow of flatter than 1:500;
 - (c) the least favourable positioning of the downpipe and bends within the gutter length;
 - (d) a cross-section or half round, quad, ogee or square; and
 - (e) the outlet to a vertical down pipe is located centrally in the sole of the eaves gutter.
- 2 The required eaves gutter discharge areas do not allow for loss of waterway due to internal brackets.

FIGURE H4 APPLICATION OF FIGURE 3.5(B)

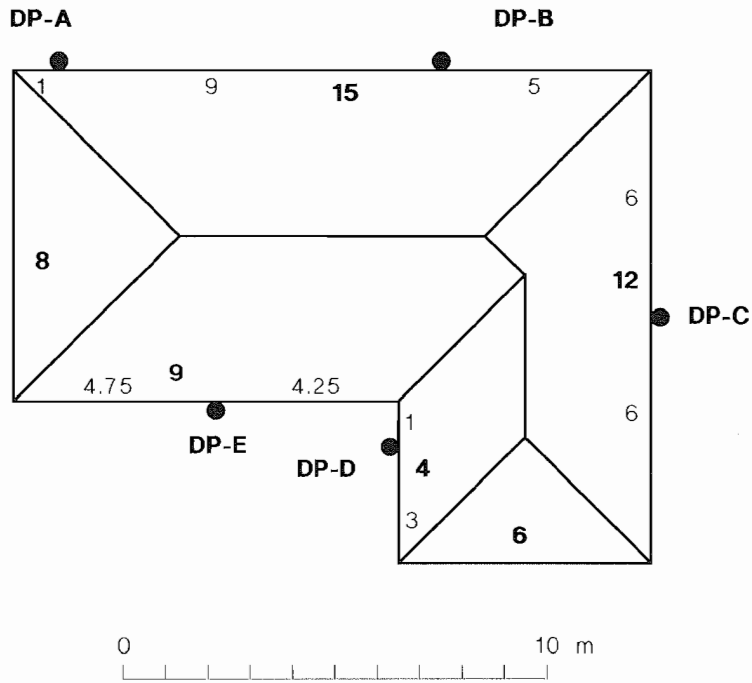

Total catchment between DP-D AND DP-A (clockwise) = 72 m²
 Catchment area for DP-E = 36 m²

FIGURE H5 ROOF PLAN—CASE 2

H2.3.2 Solution

Adopt the following:

- (a) Roof plan as shown in Figure H3 with eaves gutter gradients for Case 2 flatter than 1:500.
- (b) Eaves gutters with an effective cross-sectional area of 7300 mm².
- (c) Vertical downpipes of 85 mm diameter or 100 mm × 50 mm.
- (d) Minimum height of fascia above gutter overflow is 18 mm.

APPENDIX I
BOX GUTTER SYSTEMS—GENERAL METHOD, DESIGN GRAPHS AND
ILLUSTRATIONS

(Normative)

Figures I1 to I8 of this Appendix apply, within the limitations of Clause 3.7.1, to the general method (see Figures 3.9, 3.10 and 3.11) for the design of solutions for—

- (a) box gutters, see Figure I1; and
- (b) rainheads, see Figures I2 and I3; or
- (c) sumps with either side overflow devices, see Figures I4, I5 and I6 or high-capacity overflow devices, see Figures I7 and I8.

NOTE: Applications of this Appendix are illustrated by Examples 1, 2 and 3 given in Appendix J.

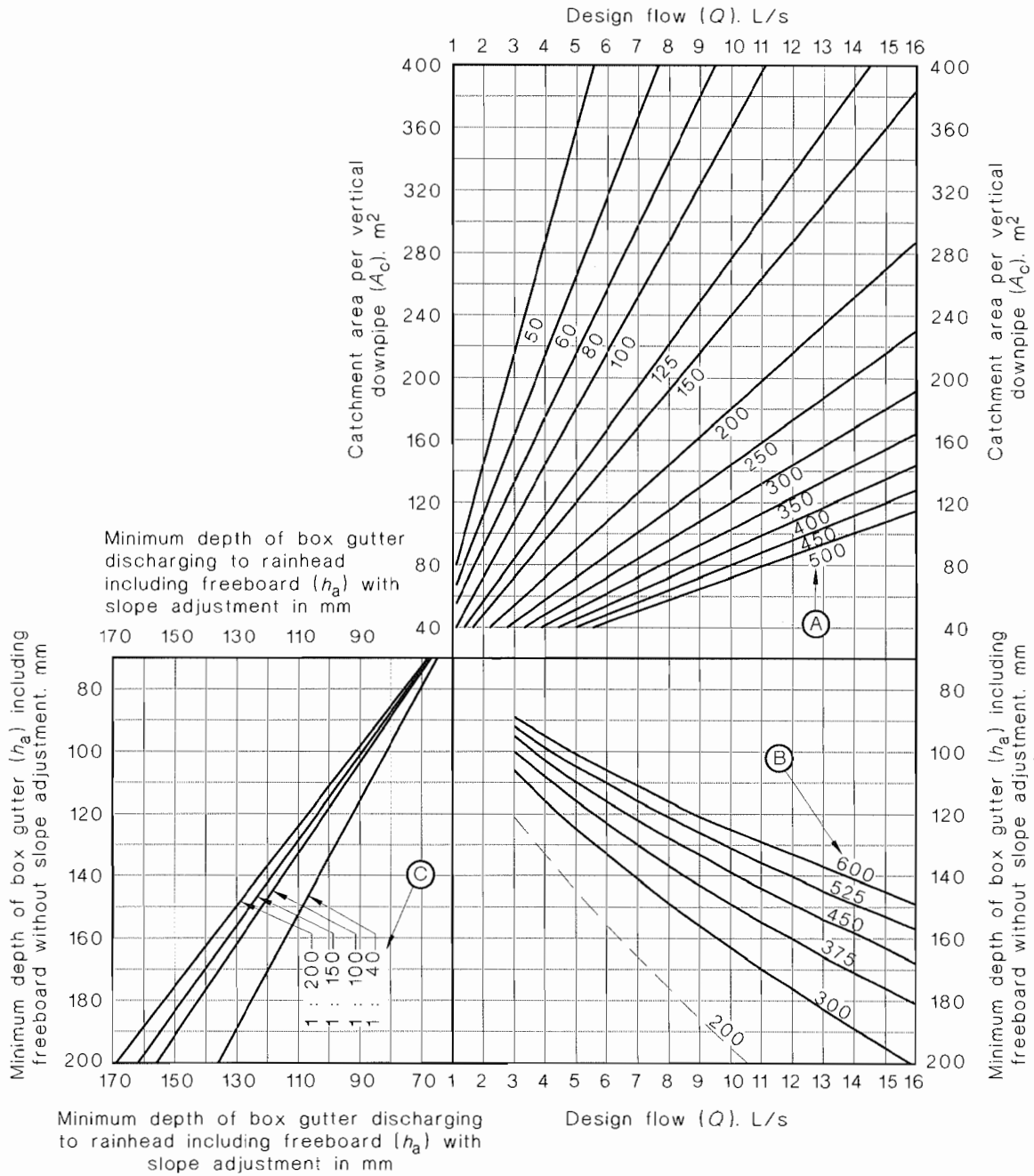

- LEGEND:
- (A) = Design rainfall intensity ($^{100}I_5$) or ($^{50}I_{10}$) in mm/hr (typical)
 - (B) = Width of box gutter (w_{bg}) in mm (typical)
 - (C) = Gradient of box gutter (typical)

NOTE: 200 mm box gutter for domestic construction only.

FIGURE 11 DESIGN GRAPH FOR A FREELY DISCHARGING BOX GUTTER

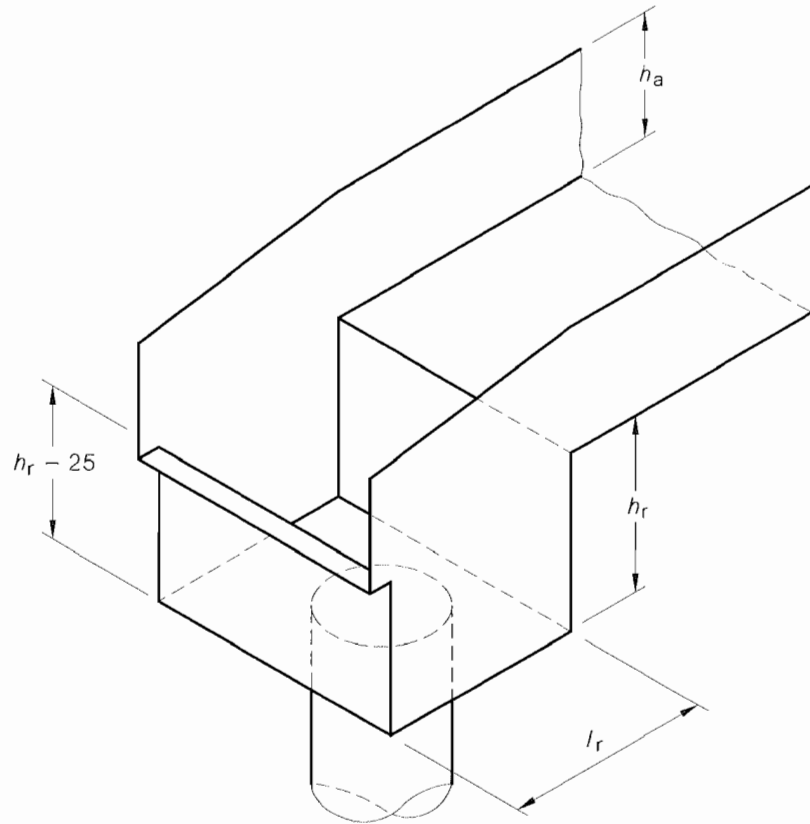

NOTES:

- 1 This figure applies for $h_r \geq 1.25 D_e$ or $1.25 D_i$
- 2 For h_r and l_r , see Figure 13.
- 3 Width of rainhead is equal to the width of box gutter.
- 4 The rainhead to be fully sealed to the box gutter and the front of the rainhead left open above the overflow weir.

FIGURE 12 RAINHEAD

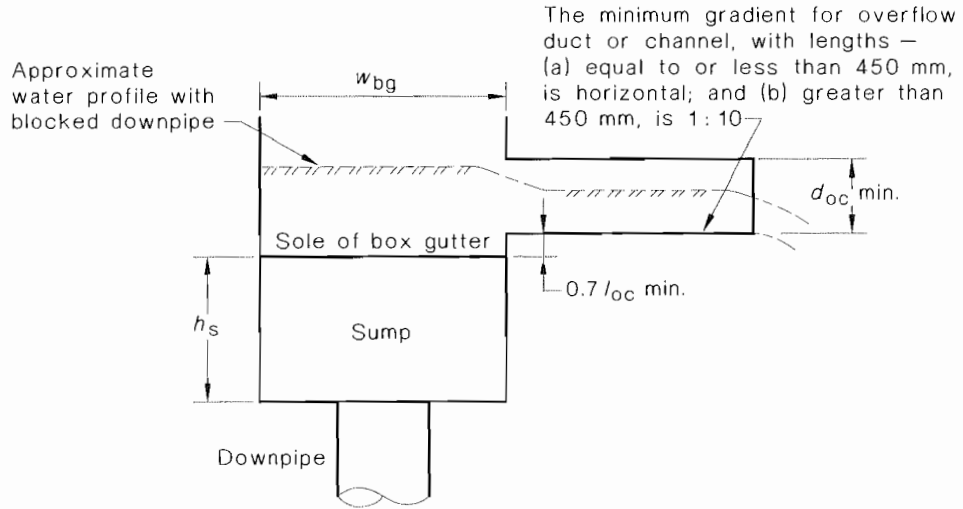

(a) Section showing overflow duct or channel

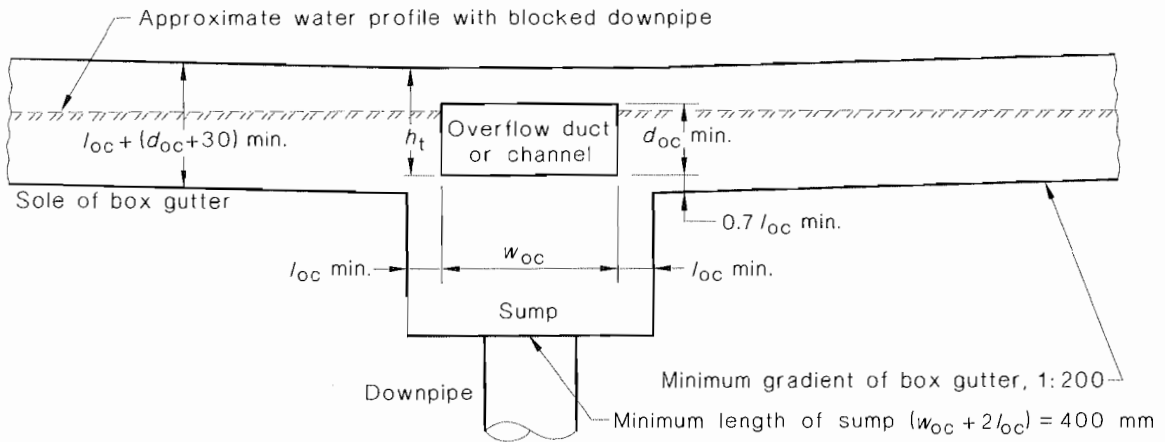

(b) Side view of box gutter

NOTE: The sump and overflow channel to be fully sealed to the box gutter.

DIMENSIONS IN MILLIMETRES

FIGURE 15 SUMP/SIDE OVERFLOW DEVICE

AI

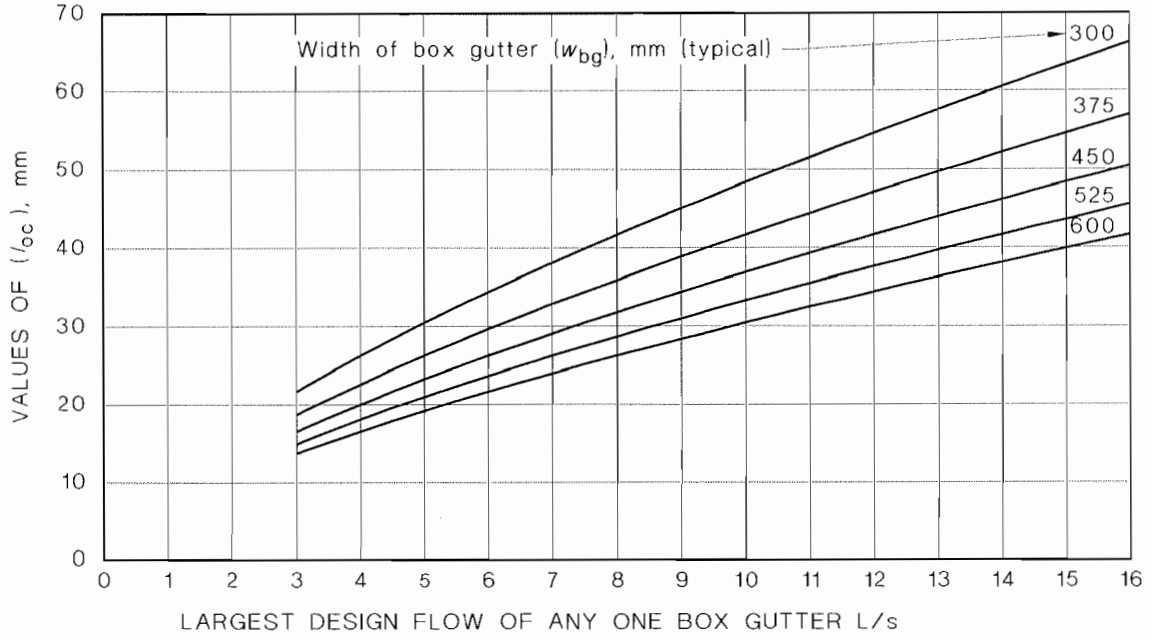

(a) Determination of values for l_{oc}

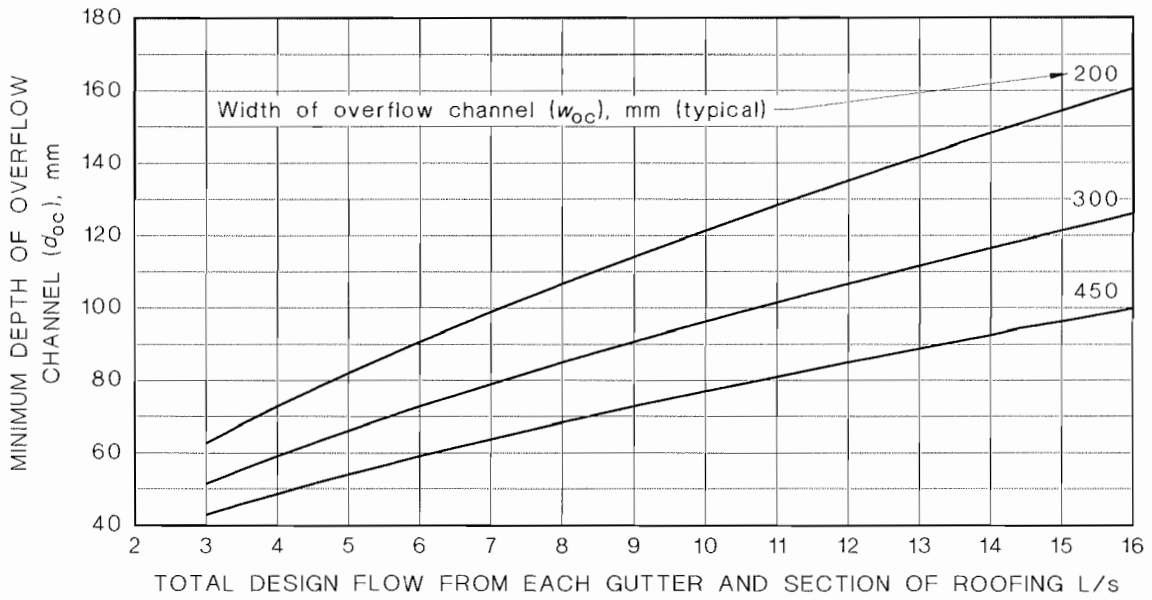

(b) Determination of values for d_{oc}

NOTE: Graph (a) applies to both sump/side overflow device, and sump/high-capacity overflow device.

FIGURE 16 DESIGN GRAPH FOR SUMP/SIDE OVERFLOW DEVICE

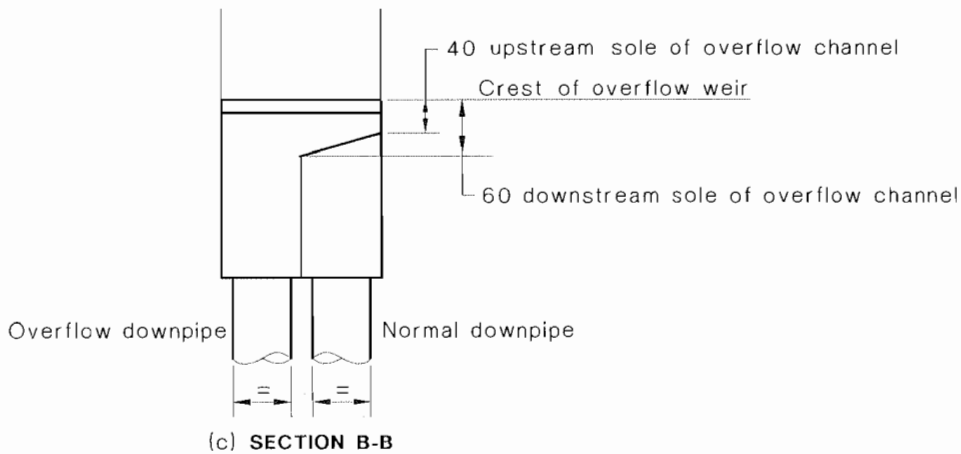
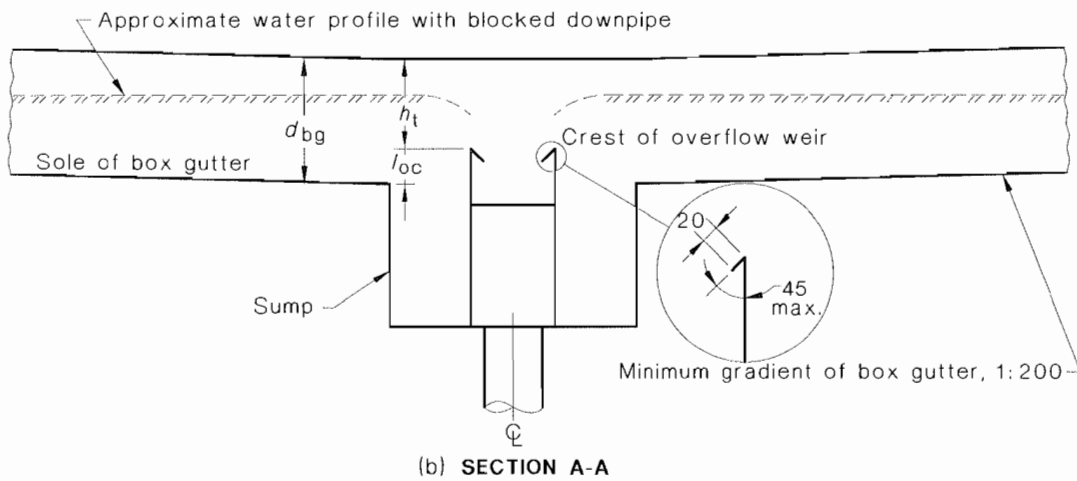
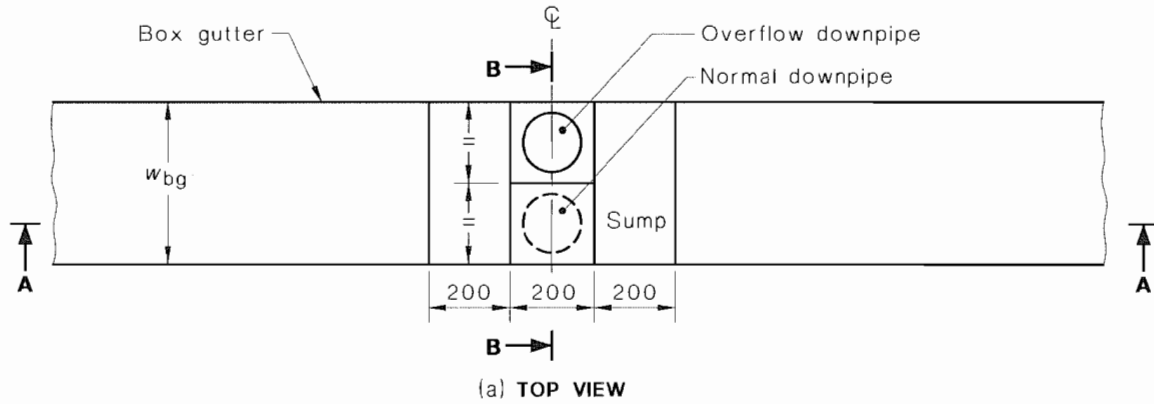

NOTES:

- 1 The depth of the sump (h_s) is measured—
 - (a) if $l_{oc} > 60$, from the sole of the box gutter at the sump; or
 - (b) if $l_{oc} < 60$, the downstream sole of the overflow channel, i.e., $60 - l_{oc}$ below the sole of the box gutter at the sump.
- 2 The sump to be fully sealed to the box gutter.
- 3 See Clause 3.7.5 for criteria for overflow devices.
- 4 The normal outlet may be moved longitudinally to enable better inspection and maintenance access (see Clause 3.7.4 (f)).

DIMENSIONS IN MILLIMETRES

FIGURE 17 SUMP/HIGH-CAPACITY OVERFLOW DEVICE

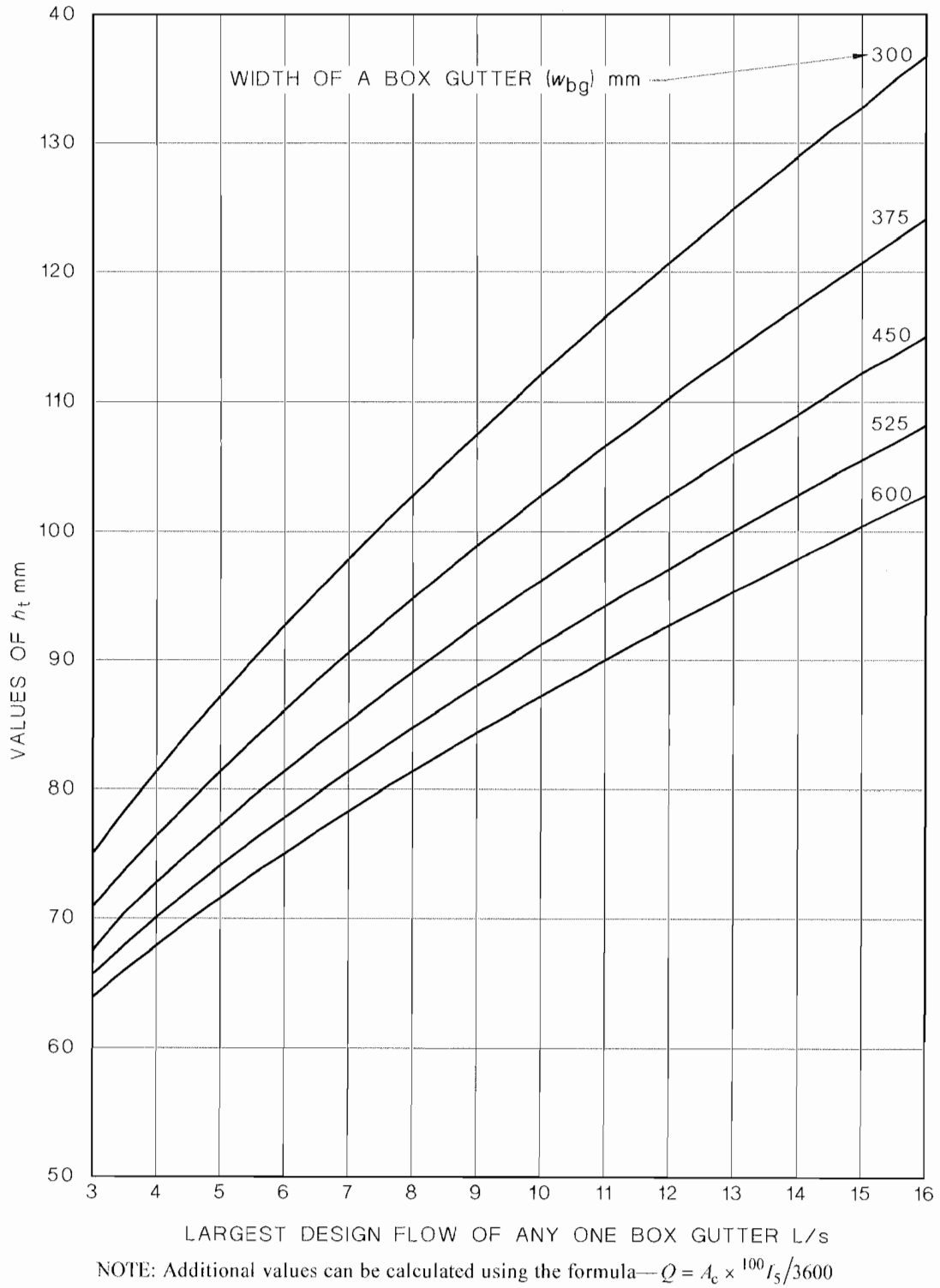

FIGURE 18 DESIGN GRAPH FOR SUMP/HIGH-CAPACITY OVERFLOW DEVICE

APPENDIX J
BOX GUTTER SYSTEMS—GENERAL METHOD—EXAMPLES
(Informative)

J1 SCOPE

This Appendix sets out examples that illustrate the application of the general method (see Clause 3.7) for the sizing of solutions for the following:

- (a) Example 1—Box gutters, rainheads and downpipes.
- (b) Example 2—Box gutters, sump/side overflow devices and downpipes.
- (c) Example 3—Box gutters, sump/high-capacity overflow devices and associated vertical downpipes.

The calculations are presented in an explanatory form to assist first and occasional users. The adopted order of accuracy in the examples is consistent with the accuracy of the assumptions on which they are based.

NOTE: Appendix D gives guidelines for the determination for any place in—

- (a) Australia, of rainfall intensities for 5 mins duration and ARIs of 20 and 100 years; and
- (b) New Zealand, of rainfall intensities for 10 mins duration and ARIs of 10 and 50 years.

J2 EXAMPLE 1: BOX GUTTERS, RAINHEADS AND DOWNPIPE**J2.1 Problem**

A building as shown in Figure J1 is to be constructed at Doncaster, a suburb of Melbourne, Victoria (see Figure E7). Determine the size of the box gutters and associated vertical downpipes with rainheads that are to discharge to the site stormwater drains of the surface water drainage system.

To assist the understanding of this example the application of Figure I1 and I3 is shown in Figure J2.

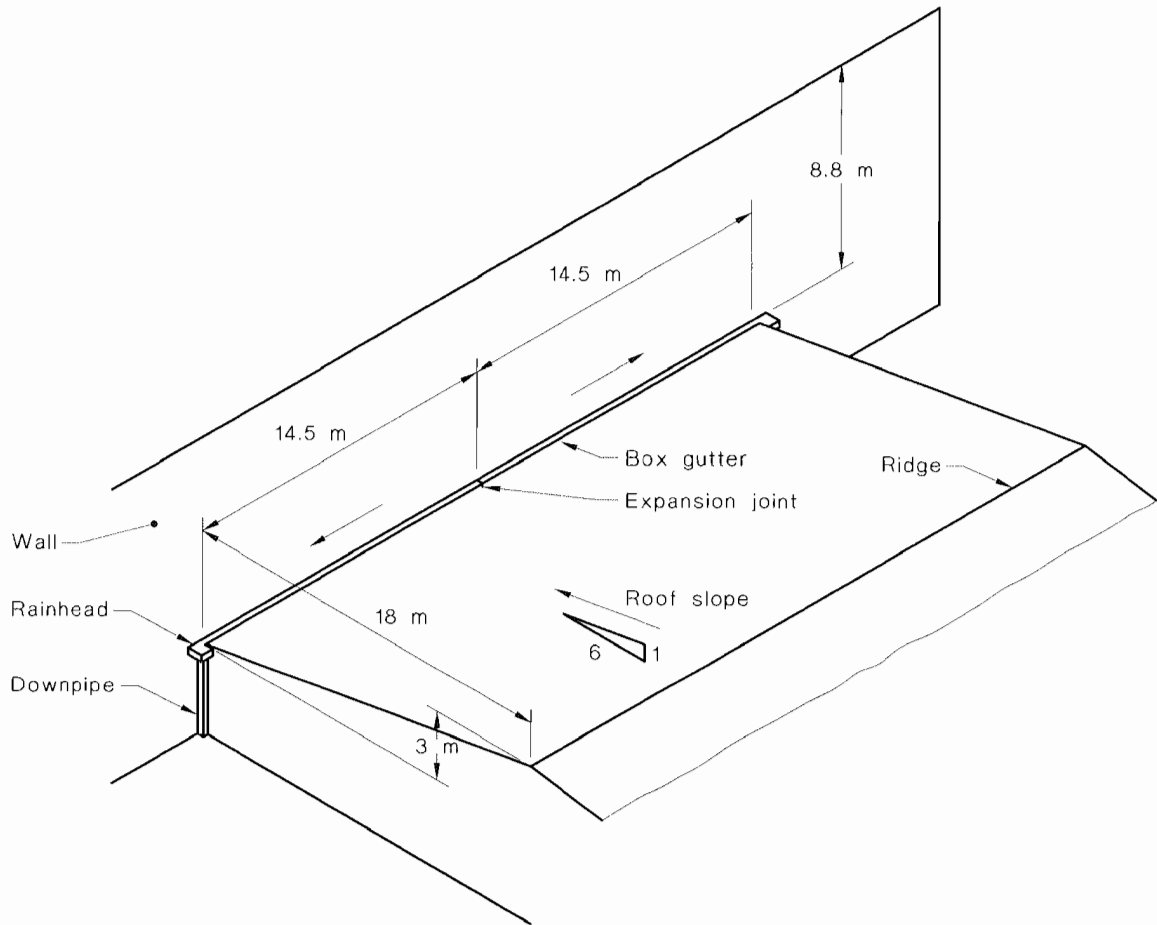

FIGURE J1 BUILDING PLAN

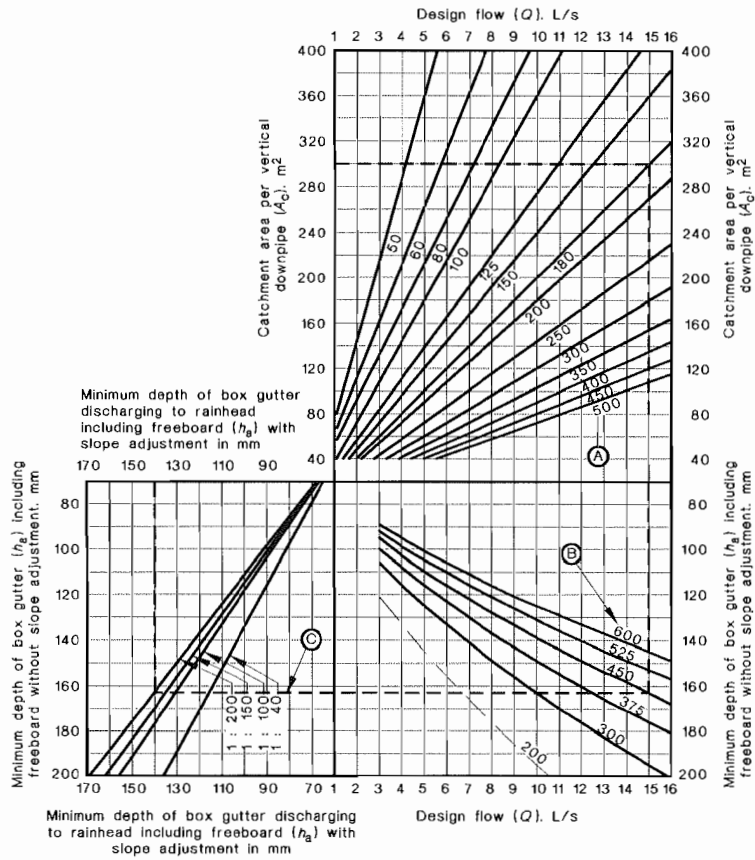

FIGURE 11 REQUIRED SIZE OF BOX GUTTER DISCHARGING TO A RAINHEAD
(a) Application of Figure 11

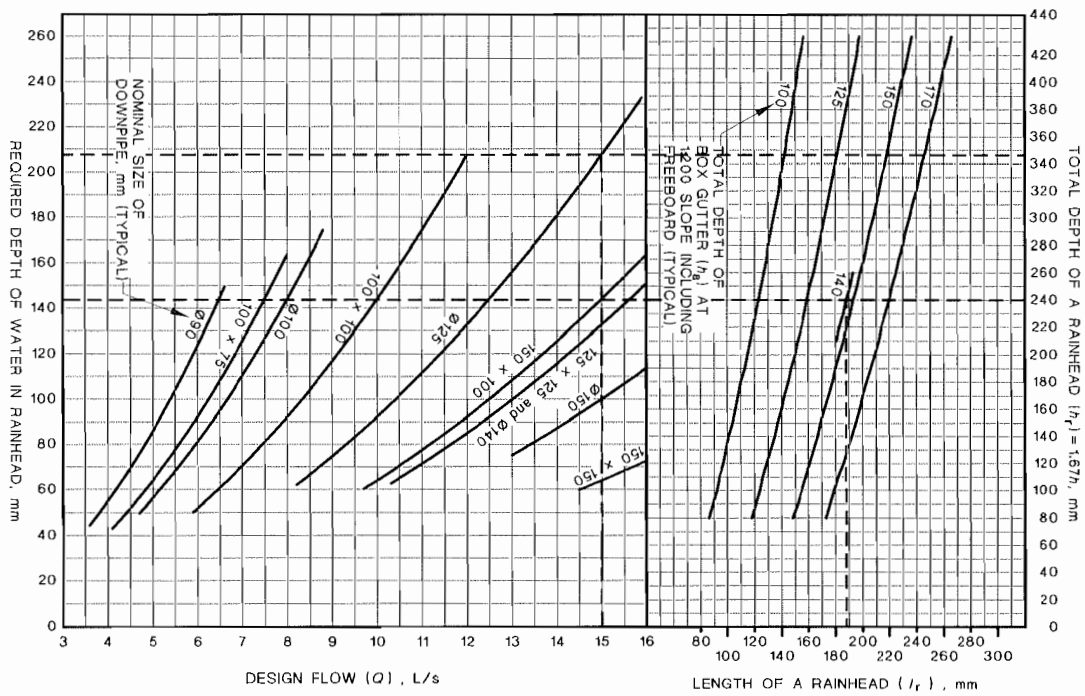

FIGURE 13 DESIGN GRAPH FOR RAINHEAD
(b) Application of Figure 13

(The figures above have been reproduced in reduced size for the purpose of this example only.
Use Figures in Appendix I when designing or checking components of box gutter systems.)

FIGURE J2 EXAMPLE 1—APPLICATION OF FIGURES 11 AND 13

J2.2 Calculation

The calculation below illustrates the application of the procedure shown in Figure 3.8. Each step designation (for example (b)) has a corresponding letter in the flow chart. Proceed as follows:

- (a) From Table 3.1, select 100 years ARI for Australia, and 50 years ARI for New Zealand.
- (b) The latitude and longitude of the site at Doncaster (Melbourne), Victoria are 37.8°S and 145.2°E.

From Figure E7, the five minutes duration, 100 year ARI rainfall intensity for the given latitude and longitude is 178 mm/h. Take this as 180 mm/h. Hence $^{100}I_5 = 180$ mm/h.

- (c) The dimensions and other relevant data are shown on Figure J1.
- (d) Select position of expansion joint and rainheads as shown in Figure J1.
- (e) Refer to Figure 3.9(b).

$$\text{Roof } A_h = 14.5 \text{ m} \times 18 \text{ m} = 261 \text{ m}^2.$$

$$\text{Roof slope } 1:6. \text{ Rise} = 1/6 \times 18 \text{ m} = 3 \text{ m}.$$

$$\text{Roof } A_{v1} = 14.5 \text{ m} \times 3 \text{ m} = 43.5 \text{ m}^2.$$

$$\begin{aligned} \text{Wall } A_{v2} &= 14.5 \text{ m} \times 8.8 \text{ m} \\ &= 127.6 \text{ m}^2 \end{aligned}$$

$$A_c = A_h + \frac{1}{2} (A_{v2} - A_{v1})$$

$$A_c = 261 \text{ m}^2 + \frac{1}{2} (127.6 - 43.5) \text{ m}^2$$

$$A_c = 303 \text{ m}^2$$

- (f) From (b), $^{100}I_5 = 180$ mm/h. From Step (e) $A_c = 303$ mm².

$$\text{From Figure I1, } Q = 15 \text{ L/s}.$$

- (g) Is the design flow $Q > 16$ L/s.? No. Go to Step (h).
- (h) From Figure I1, for $Q = 15$ L/s, select sole width of box gutter (w_{bg}) = 450 mm and gradient = 1:200.
- (i) From Figure I1, for $Q = 15$ L/s, $w_{bg} = 450$ and gradient = 1:200, the actual minimum depth of box gutter including freeboard (h_a) = 140 mm.

As each box gutter discharges to a rainhead that is designed to divert the design flow away from the building in the event of a total blockage of the downpipe, without increasing the depth of flow in the box gutter, this is the minimum depth required for the box gutter.

Use box gutters 450 mm × 140 mm minimum with a gradient 1:200.

- (j) The design flow in each box gutter is also the design flow in the rainhead. From Step (f), $Q = 15$ L/s.

Select 125 mm diameter downpipe. From Figure I3, depth of water in rainhead = 207 mm, total depth of rainhead $h_r = 345$ mm.

Alternatively, select 150 mm × 100 mm downpipe. From Figure I3, depth of water in rainhead = 144 mm, total depth of rainhead $h_r = 240$ mm. Use total depth of rainhead = 250 mm.

- (k) Check if the total depth h_r needs to be adjusted as required by Note 1 of Figure I2 RAINHEAD.

- (l) From Figure I3, for $h_a = 140$ mm, length of rainhead (l_r) = 185 mm (use 200 mm), and total depth of rainhead (h_r) = 250 mm.
- (m) Refer to Figure I2 and Figure 3.7(a). Final dimensions of rainhead, $h_r = 250$ mm, $h_r - 25 = 225$ mm, $h_a = 150$ mm. $l_r = 200$ mm.

J3 EXAMPLE 2: BOX GUTTERS, SUMP/SIDE OVERFLOW DEVICES AND DOWNPIPES

J3.1 Problem

A building as shown in Figure J3 is to be constructed in Brisbane, Queensland (see Figure E3). Determine the size of the box gutters and the associated vertical downpipe with sump/side overflow device that is to discharge to the site stormwater drains of the surface water drainage system.

To assist the understanding of this example the application of Figures I4 and I6 is shown in Figure J4.

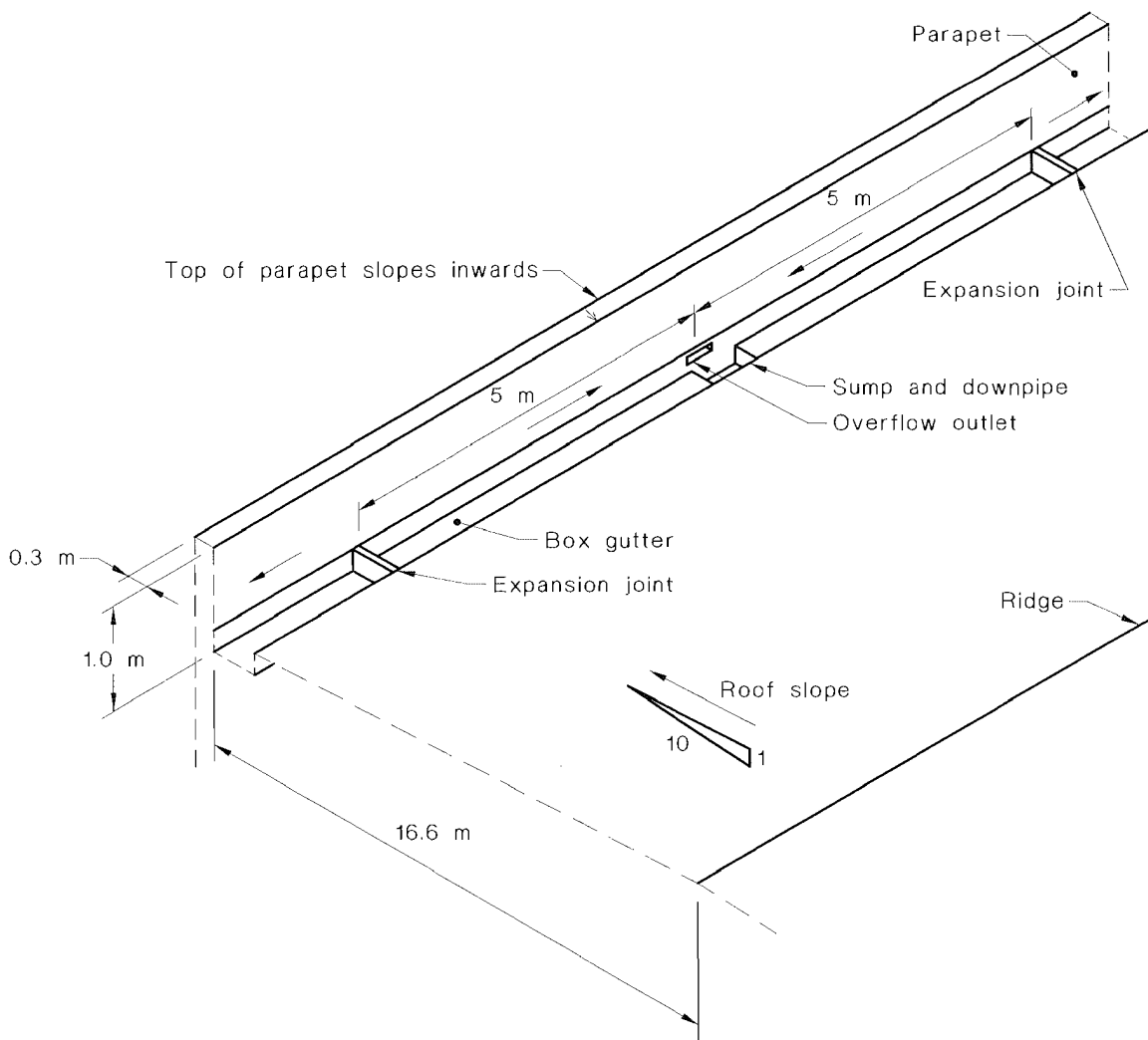

FIGURE J3 ROOF PLAN

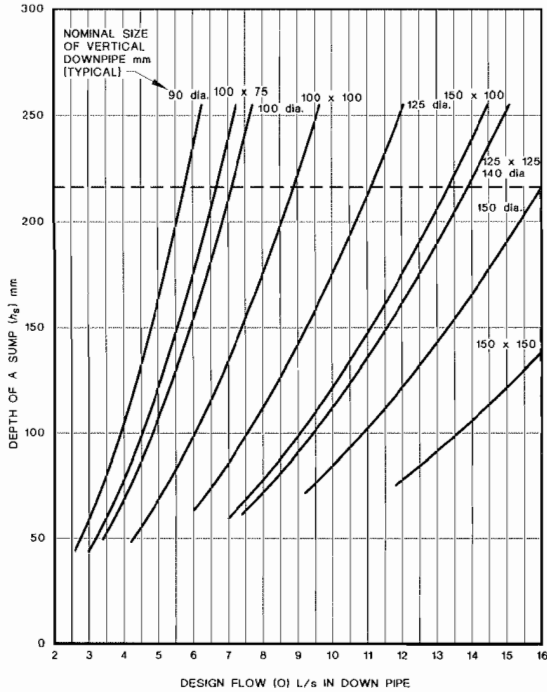
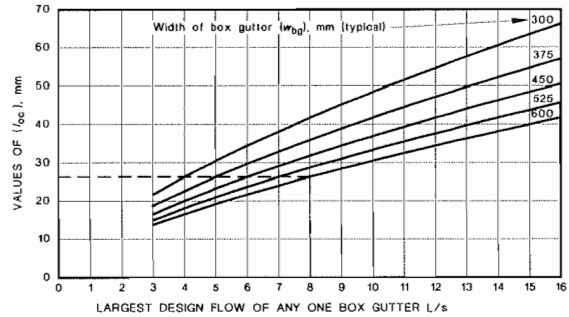

FIGURE I4 DESIGN GRAPH FOR SUMP

(a) Application of Figure I4

(The figures above have been reproduced in a reduced size for the purpose of this example only. Use Figures in Appendix 1 when designing or checking components of box gutter systems.)



(a) Determination of values for l_{oc}

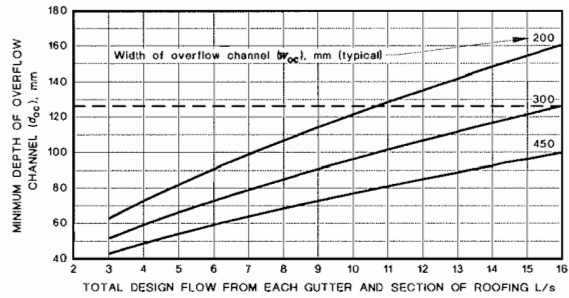

(b) Determination of values for d_{oc}

FIGURE I6 REQUIRED SIZE OF SUMP/SIDE OVERFLOW DEVICE

(b) Application of Figure I6

FIGURE J4 EXAMPLE 2 —APPLICATIONS OF FIGURES I4 AND I6

J3.2 Calculation

The calculation below illustrates the application of the procedure shown in Figure 3.9. Each step designation (for example Step (b)) has a corresponding letter in the flow chart. Proceed as follows:

- (a) From Table 3.1, select 100 years ARI for Australia, and 50 years ARI for New Zealand, for box gutters with a normal factor of safety.
- (b) From Figure D3, the 5 min duration, 100 year ARI rainfall intensity ($^{100}I_5$) for Brisbane is 330 mm/h.
- (c) The dimensions and other relevant data are shown in Figure J3.
- (d) Expansion joints are installed at 10 m intervals along the box gutter near the parapet with sumps and downpipes midway between the expansion joints (see Figure J3).
- (e) With reference to Figure 3.9(b), the parapet 300 mm wide directs rain falling on top surface into the box gutter. Therefore, include as catchment area (see Clause 3.4).

Length of roof + parapet = 16.9 m.

Roof $A_h = 5 \text{ m} \times 16.9 \text{ m} = 84.5 \text{ m}^2$.

Roof slopes at 1:10.

Roof rise = $1/10 \times 16.6 \text{ m} = 1.7 \text{ m}$.

Roof $A_{v2} = 5 \text{ m} \times 1.7 \text{ m} = 8.5 \text{ m}^2$.

Parapet $A_{v1} = 5 \text{ m} \times 1 \text{ m} = 5 \text{ m}^2$.

$$A_c = A_h + \frac{1}{2} (A_{v2} - A_{v1})$$

$$A_c = 84.5 + \frac{1}{2} (8.5\text{m}^2 - 5\text{m}^2)$$

$$A_c = 86.3 \text{ m}^2.$$

- (f) From (b) $^{100}I_5 = 330 \text{ mm/h}$. From Step (e), $A_c = 86.3 \text{ mm}^2$.

From Figure 11, $Q = 8 \text{ L/s}$ for each gutter.

- (g) Sole width = 600 mm, gradient of box gutters = 1:200
- (h) Is the total design flow through the outlet $Q > 16 \text{ L/s}$? No. Go to Step (i).
- (i) Are the gradients of the box gutters flatter than 1:200? No. Go to Step (j).
- (j) Total design flow = $2 \times 8 = 16 \text{ L/s}$. Select 150 mm diameter downpipe. From Figure 14 and 15, $h_s = 220 \text{ mm}$.
- (k) For either box gutter $Q_{\text{max.}} = 8 \text{ L/s}$. From Figure 16(a), $l_{oc} = 26 \text{ mm}$.
- (l) Select width of overflow weir $w_{oc} = 300 \text{ mm}$.
- (m) Total design flow = 16 L/s. From Item (l), $w_{oc} = 300 \text{ mm}$. From Figure 16(b), $d_{oc} = 132 \text{ mm}$. From (k), $l_{oc} = 26 \text{ mm}$. $h_t = (l_{oc} + (d_{oc} + 30)) - (0.7 l_{oc}) = 170 \text{ mm}$. Alternatively, if $w_{oc} = 450 \text{ mm}$. From Figure 16(b) $d_{oc} = 102 \text{ mm}$, $h_t = 140 \text{ mm}$.
- (n) From (k), $l_{oc} = 26 \text{ mm}$. For $w_{oc} = 300 \text{ mm}$, $d_{bg} = l_{oc} + (d_{oc} + 30) = 188 \text{ mm}$. For $w_{oc} = 450 \text{ mm}$, $d_{bg} = l_{oc} + (d_{oc} + 30) = 158 \text{ mm}$. Select appropriate option, say $d_{bg} = 188 \text{ mm}$. Go to (o).
- (o) Refer to Figure 15 and Figure 3.7(b). Sump details. From Step (j), depth of sump $h_s = 220 \text{ mm}$. Width of sump = $w_{oc} + 2 l_{oc} = 300 + 2 \times 26 = 352 \text{ mm}$ min. This is less than the allowable minimum of 400 mm (Figure 15). Use 400 mm.

Overflow duct details. For $w_{oc} = 300$, $d_{oc} = 132 \text{ mm}$. Hence, overflow duct opening 300 mm \times 132 mm for depth of box gutter = 188 mm. Bottom edge of duct $0.7 \times 26 = 18 \text{ mm}$ above sole of gutter.

J4 EXAMPLE 3: BOX GUTTERS, SUMP/HIGH-CAPACITY OVERFLOW DEVICES AND DOWNPIPES

J4.1 Problem

A sump/high-capacity overflow device is to be fitted to the outlet of 5.0 m long and 3.8 m long box gutters with gradients of 1:200 and sole widths of 600 mm. Inflow from the catchment area of the roof is at the rate of 1.7 L/s/m. Determine the size of the box gutters and the sump/high-capacity overflow device including the normal and overflow vertical downpipes.

To assist the understanding of this example the application of Figures 14, 16(a) and 18 is shown in Figure J5.

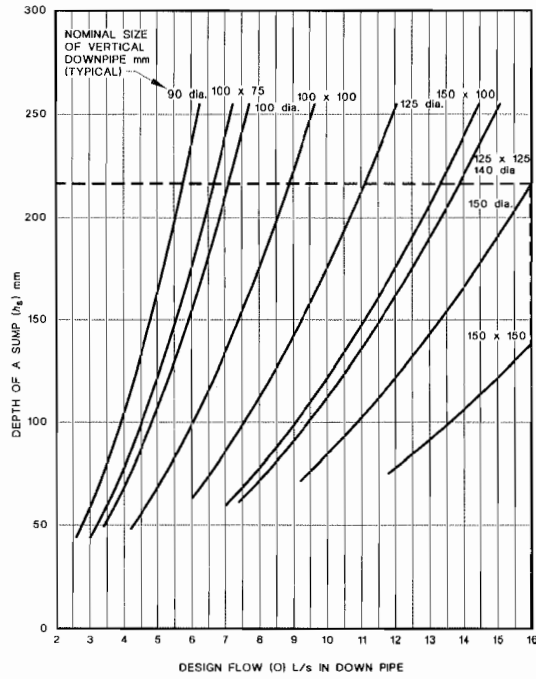
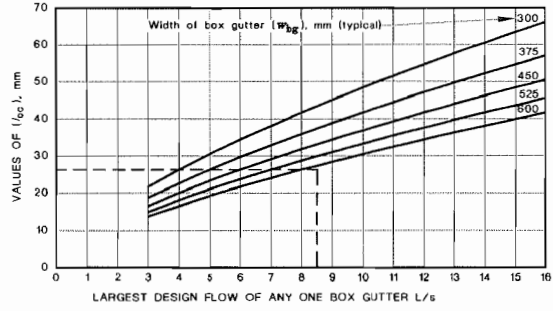

FIGURE 14 DESIGN GRAPH FOR SUMP

(a) Application of Figure 14



(a) Determination of values for l_{oc}

FIGURE 16 DESIGN GRAPH FOR SUMP/SIDE OVERFLOW DEVICE

(b) Application of Figure 16

FIGURE J5 (in part) EXAMPLE 3—APPLICATION OF FIGURES 14, 16(a) AND 18

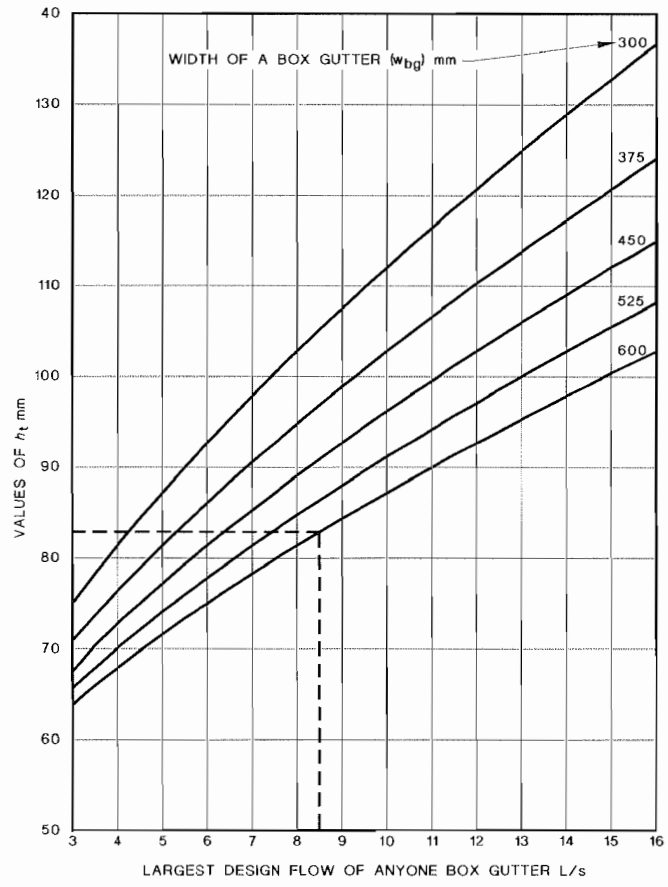

FIGURE I8 REQUIRED SIZE OF SUMP/HIGH-CAPACITY OVERFLOW DEVICE

(c) Application of Figure I8

FIGURE J5 (in part) EXAMPLE 3—APPLICATION OF FIGURES I4, I6(a) AND I8

TABLE J1
DATA FOR EXAMPLE 3

| Item | Length | Design flow | | Depth of box gutter with discharge to rainhead (h_a) from Figure I1 | Width w_{bg} |
|------------|-----------------|-------------|-------------|---|----------------|
| | m | L/s | | mm | mm |
| Box gutter | | | | | |
| (a) | 5.0 | 8.5* | (1.7 × 5.0) | 105 | 600 |
| (b) | 3.8 | 6.5 | (1.7 × 3.8) | 98 | 600 |
| Sump | 0.6 | 1.0 | (1.7 × 0.6) | — | — |
| | (see Figure I7) | | | | |
| Totals | 9.4 | 16.0† | | — | — |

* Largest design flow from any one box gutter.

† Total design flow from each box gutter and section of roofing.

J4.2 Calculation

The calculation below illustrates the application of the procedure shown in Figure 3.10. Each step designation (for example (b)) has a corresponding letter in the flow chart. Proceed as follows:

- (a) From Table 3.1, select 100 years ARI for Australia, and 50 years ARI for New Zealand, for box gutters with a normal factor of safety.
- (b) (Steps (b) to (g)). The procedure for the determination of the catchment areas and design flows is illustrated in Appendix J, Examples 1 and 2. The procedure for the determination of the minimum depth of box gutter (h_a) for free flow conditions is the same as for a box gutter served by a rainhead shown in Example 1. Table J1 summarizes the results of these procedures for a selected width of box gutter (w_{bg}) = 600 mm.
- (c) Is the total design flow through the outlet >16 L/s? No. Go to Step (i).
- (d) Select 1:200 min. gradient of box gutters. Go to Step (j).
- (e) Total design flow = 16 L/s. From Figure I4, for a 150 mm diameter downpipe, the depth of sump (h_s) = 217 mm. Adopt 220 mm.
- (f) $Q_{max.} = 8.5$ L/s for any box gutter. Width of box gutter = 600 mm. From Figure I6(a), $l_{oc} = 27$ mm.
- (g) If the downpipe ceases to function because of a blockage, the water level at the ends of the box gutters will increase to discharge the design flow across the overflow weirs. From Table J1, the largest flow in any box gutter is $Q = 8.5$ L/s. From Figure I8, for $Q = 8.5$ L/s and $w_{bg} = 600$ mm, the minimum height of the box gutter above the top of the overflow weirs (h_t) = 83 mm.
- (h) The depth of box gutter has to be sufficient to contain the flow under overflow conditions without overtopping. Usually, the minimum total depth of gutter (d_{bg}) required for this condition is more than the minimum total depth of gutter (h_a) required when there are no blockages. But for wide gutters this is not always the case, partly because of different levels of freeboard incorporated in the graphs.

From Step (g) (shown on summary Table J1), $h_a = 105$ mm. From (l), $h_t = 83$ mm. From (k), $l_{oc} = 27$ mm. $h_t + l_{oc} = 110$ mm.

Is $h_a(105) < h_t + l_{oc} (110)$? Yes. Go to Step (n).

- (i) The minimum depth of box gutter $d_{bg} = h_t + l_{oc} = 110$ mm.
- (j) Is $l_{oc} > 60$? No? Go to Step (p).
- (k) The datum level for depth of the sump is the sole of the box gutter.
- (l) Refer to Figure I7. Sump details. From Step (j), depth = 220 mm minimum below sole of gutter. Length = 600 mm. Width = 600 mm.

Overflow weirs. From Step (k), crest of weir above sole of gutter = 27 mm.

From Step (n), depth of box gutter = 110 mm minimum.

APPENDIX K

SURFACE DRAINAGE SYSTEMS—NOMINAL AND GENERAL METHODS—
EXAMPLES

(Informative)

K1 SCOPE

This Appendix sets out examples that illustrate the application of the nominal method (see Clauses 5.5) and the general method (see Clause 5.4) for the design of solutions for surface drainage systems.

The calculations are presented in an explanatory form to assist first and occasional users. The adopted order of accuracy in the examples is consistent with the accuracy of the assumptions on which they are based.

NOTE: Appendix D gives guidelines for the determination for any place in—

- (a) Australia, of rainfall intensities for five minutes duration and ARIs of 20 and 100 years; and
- (b) New Zealand, of rainfall intensities for 10 minutes duration and ARIs of 10 and 50 years.

K2 EXAMPLE 1: NOMINAL METHOD**K2.1 Problem**

A house on an urban allotment with an area not exceeding 1000 m² as shown in Figure K1 is to be located in Australia. Design the surface drainage system constructed with non-metal products.

K2.2 Solution**K2.2.1 Layout**

The layout of the surface drainage system shown, which is in Figure K1, shall comply with Clause 5.3 and have the site landscaped so that the overland flow path is directed away from the building, e.g., the cross-fall of a paved path along rear of the building is to be away from the building.

K2.2.2 Site stormwater drains

For the site stormwater drains —

- (a) the minimum size, determined from Clause 7.3.4 is —
 - (i) between a downpipe outlet and a stormwater or inlet pit, DN 90;
 - (ii) between the stormwater, pits A and B, DN 150; and
 - (iii) between pit B (see Clause 8.6.1.2(b)) and the street kerb, two DN 100;
- (b) the minimum cover, determined from Table 7.1 is—
 - (i) within the property —
 - (A) other than under the driveway, 100 mm; and
 - (B) under the paved driveway, 75 mm below the underside of the pavement; and
 - (ii) outside the property under the paved footpath, 50 mm below the underside of the pavement; and
- (c) the minimum gradient, determined from Table 7.2 for Australia, is DN 90, DN 100 and DN 150, 1:100.

K2.3 Stormwater pits

For stormwater pits—

- (a) the minimum internal dimensions, determined from Table 8.2, are at A and B, 450 mm × 450 mm (depth to invert of outlet less than 600 mm).
- (b) the minimum fall across each pit is 20 mm (see Figure 8.4(a)).

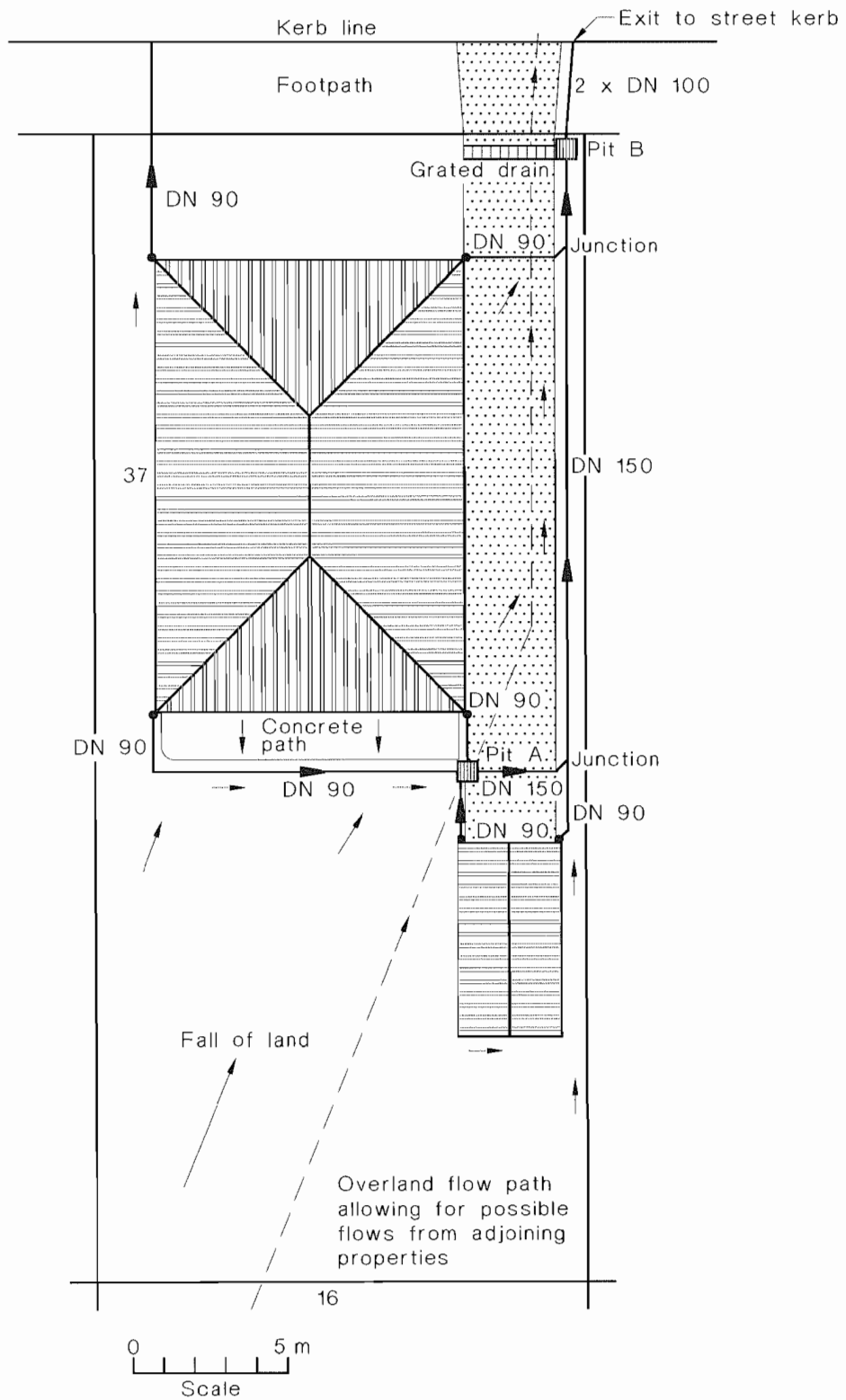

LEGEND:

- Downpipe, outlet =
- Stormwater pit =
- Site stormwater drain =

DIMENSIONS IN METRES

FIGURE K1 STORMWATER DRAINAGE INSTALLATION PLAN—EXAMPLE 1

K3 EXAMPLE 2: GENERAL METHOD—VILLA HOME DEVELOPMENT

K3.1 Problem

A three-unit villa home development is to be located in Melbourne, Victoria, on a property with an area of 912 m^2 ($48 \text{ m} \times 19 \text{ m}$) as shown in Figure K2. The property slopes away from the street, and since there is some risk of flooding of the garage for Unit 3, a grated drain is provided in front of this. For the same reason, an ARI of five years should be adopted for the sizing of the surface water drainage system.

K3.2 Assumptions

It is assumed that there is little chance of overflows from the street gutter coming through this property. However, the site drainage path has to be well established, with any overflows being collected in pits or directed beside buildings to the easement drain running through the lower part of the site. Specifically, there should be gaps under fences adjacent to Pits 2 and 4, so that any overflows can escape without ponding against fences.

Roof water is collected from the vertical downpipes. Each downpipe for the villa house can be assumed to drain 25% of the associated roof. Downpipes on garages can be assumed to collect all of the rainwater from a roof plane.

It is assumed that the paved areas will be reinforced concrete and be capable of taking medium vehicle loads. Thus cover depths can be small—a minimum of 100 mm below the pavement (say 200 mm overall) will apply. In courtyards without paving, a cover of 100 mm will be required (see Table 7.1).

K3.3 Solution

K3.3.1 Preliminary

Determine, for an ARI of 5 years, values for the following:

- The rainfall intensity for a 5 min duration (5I_5) is 87 mm/h (see Clause 5.4.5(a)).
- Assuming loam soils, the run-off coefficient for the un-roofed pervious area (C_p) is $0.147 \times 0.95 = 0.14$ for a ${}^{10}I_{60}$ of 28.6 mm/h (see Equation 5.4.6 in Clause 5.4.6(a)).

K3.3.2 Procedure

A trial surface water drainage system is shown in Figure K2. In this case, it is most convenient to establish this as two subsystems, running on either side of the lower Unit 3. Plastic pipes are assumed to be used, having a roughness coefficient $k = 0.015 \text{ mm}$ (see Table 5.6).

Table K1 can be set up on a spreadsheet program that enables the automatic determination of the values shown in the shaded areas. The column numbers below refer to Table K1:

Column 1—identifies the limits for each section of the site stormwater drain.

Column 2—gives for each section the length.

Columns 3, 4 and 5—give the catchment area for each section, respectively, for the upstream—

- roof, the plan area irrespective of the roof slope;
- unroofed impervious (paved) area; and
- unroofed pervious area.

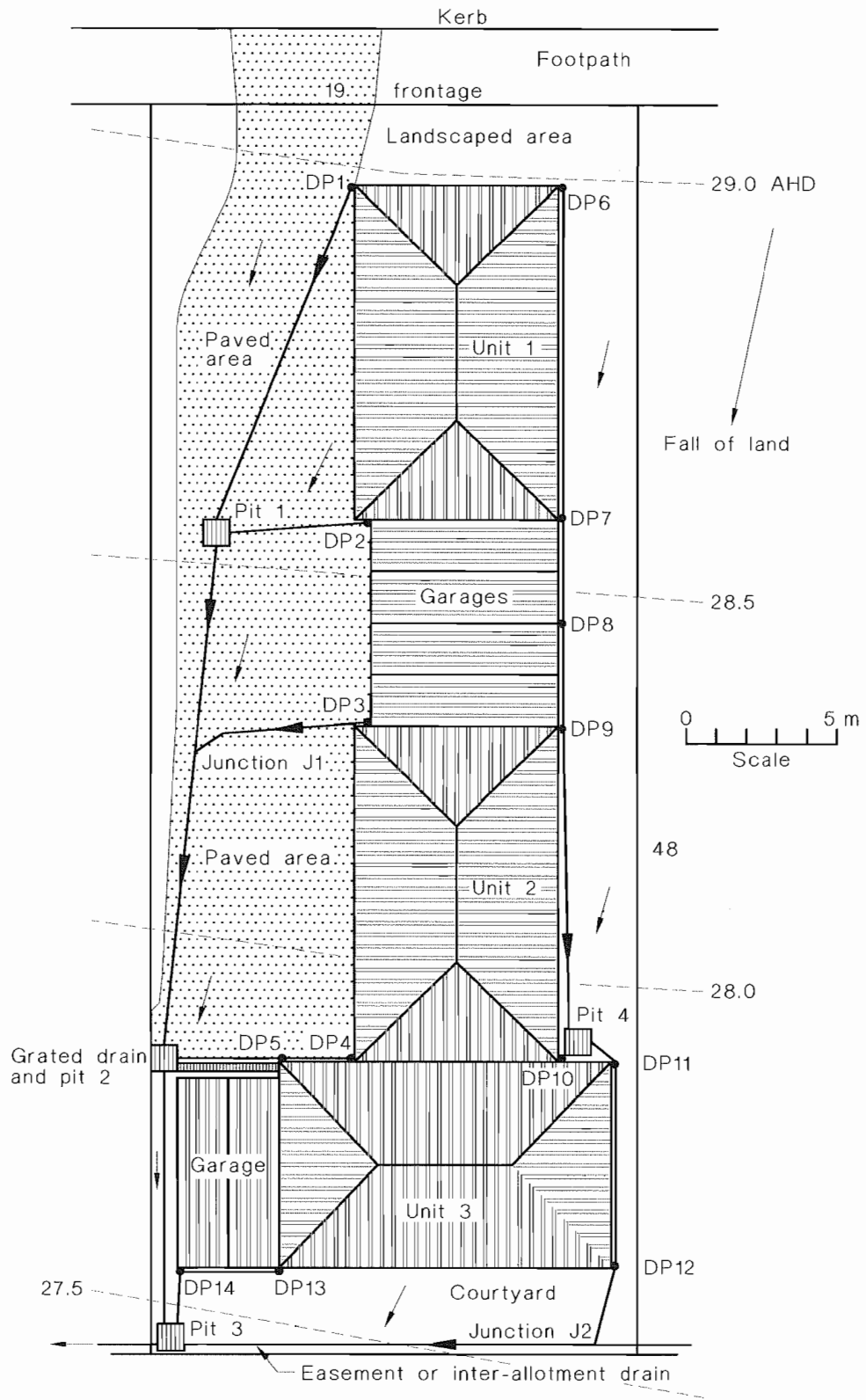

- LEGEND:
- Downpipe, outlet = ●
 - Stormwater pit = [Symbol: rectangle with vertical lines]
 - Site stormwater drain = [Symbol: line with T-junction]

DIMENSIONS IN METRES

FIGURE K2 STORMWATER DRAINAGE INSTALLATION PLAN—EXAMPLE 2

TABLE K1
CALCULATION SHEET—EXAMPLE 2

| 1 | 2 | 3 | 4 | 5 | 6 | 7 | 8 | 9 | 10 | 11 | 12 | 13 | 14 | 15 | 16 | 17 | 18 | 19 |
|-------------------|--------|-----------|------------|---------------|---|------------|--------------|------------|---------------|---------------|--------------------|--------------------------|-------------------|-------------------|------------|------------|---------|------|
| Conduit | Length | Roof area | Paved area | Pervious area | Equivalent impervious area m ² | | Design flows | Pipe diam. | Pipe gradient | Pipe capacity | Full-pipe velocity | Min. fall across U/S pit | U/S surface level | D/S surface level | U/S invert | D/S invert | Cover m | |
| | | | | | Sub-catchment | Cumulative | | | | | | | | | | | L/s | mm |
| DP1 to Pit 1 | 14.2 | 26 | 0 | 0 | 26 | 26 | 0.6 | 90 | 25 | 12 | 0.10 | NA | 28.95 | 28.55 | 28.61 | 28.04 | 0.25 | 0.42 |
| DP2 to Pit 1 | 5.7 | 26 | 0 | 0 | 26 | 26 | 0.6 | 90 | 21 | 14 | 0.10 | NA | 28.60 | 28.55 | 28.31 | 28.04 | 0.20 | 0.42 |
| Pit 1 to J1 | 19.4 | 0 | 96 | 64 | 95 | 147 | 3.6 | 150 | 67 | 28 | 0.20 | 0.02 | 28.50 | 28.25 | 28.02 | 27.73 | 0.33 | 0.37 |
| DP3 to J1 | 6.9 | 26 | 0 | 0 | 26 | 26 | 0.6 | 90 | 25 | 12 | 0.10 | NA | 28.30 | 28.25 | 28.01 | 27.73 | 0.20 | 0.43 |
| J1 to Pit 2 | 11.5 | 0 | 0 | 0 | 0 | 173 | 4.2 | 150 | 25 | 48 | 0.24 | NA | 28.25 | 27.80 | 27.73 | 27.27 | 0.37 | 0.38 |
| DP4, DP5 to Pit 2 | 7.1 | 52 | 0 | 0 | 52 | 52 | 1.3 | 90 | 24.5 | 12 | 0.20 | NA | 27.85 | 27.80 | 27.56 | 27.27 | 0.20 | 0.44 |
| Pit 2 to Pit 3 | 10.2 | 0 | 154 | 21 | 142 | 367 | 8.9 | 150 | 25 | 48 | 0.50 | 0.02 | 27.80 | 27.45 | 27.25 | 26.84 | 0.40 | 0.46 |
| DP13 to DP14 | | 41 | 0 | 0 | 41 | 41 | 1.0 | 90 | 67 | 7.5 | 0.16 | NA | 27.55 | 27.53 | 27.26 | 27.26 | 0.20 | 0.18 |
| DP14 to Pit 3 | 2 | 15 | 0 | 0 | 15 | 56 | 1.4 | 90 | 20 | 14 | 0.21 | NA | 27.53 | 27.45 | 27.20 | 27.10 | 0.24 | 0.26 |
| DP6 to DP7 | 13 | 26 | 0 | 0 | 26 | 26 | 0.6 | 90 | 25 | 12 | 0.10 | NA | 29.00 | 28.60 | 28.71 | 28.19 | 0.20 | 0.32 |
| DP7 to DP8 | 4 | 41 | 0 | 0 | 41 | 67 | 1.6 | 90 | 25 | 12 | 0.25 | NA | 28.60 | 28.45 | 28.19 | 28.03 | 0.32 | 0.33 |
| DP8 to DP9 | 4 | 30 | 0 | 0 | 30 | 97 | 2.3 | 90 | 33 | 11 | 0.37 | NA | 28.55 | 28.35 | 28.03 | 27.91 | 0.43 | 0.35 |
| DP9 to Pit 4 | 12 | 41 | 0 | 0 | 41 | 138 | 3.3 | 90 | 25 | 12 | 0.52 | NA | 28.35 | 27.90 | 27.91 | 27.43 | 0.35 | 0.38 |
| Pit 4 to DP11 | 1.4 | 26 | 0 | 102 | 40 | 178 | 4.3 | 150 | 33 | 40 | 0.24 | 0.02 | 27.90 | 27.90 | 27.43 | 27.39 | 0.32 | 0.36 |
| DP11 to DP12 | 8 | 26 | 0 | 0 | 26 | 204 | 4.9 | 150 | 33 | 40 | 0.28 | NA | 27.90 | 27.60 | 27.39 | 27.15 | 0.36 | 0.30 |
| DP12 to J2 | 3 | 26 | 0 | 0 | 26 | 230 | 5.6 | 150 | 33 | 40 | 0.31 | NA | 27.60 | 27.55 | 27.15 | 27.06 | 0.30 | 0.34 |
| Pit to easement | 0 | 0 | 0 | 73 | 10 | 29 | 0.7 | — | — | — | — | — | 27.45 | — | — | — | — | — |

Sums = 402 250 260

Total area = 912 m²

LEGEND:

- U/S = upstream
- D/S = downstream
- NA = not applicable

Column 6—gives for each section the equivalent impervious area calculated from the following equation:

$$\Sigma CA = C_r A_r + C_i A_i + C_p A_p \quad \dots \text{K3.3.2(1)}$$

where

ΣCA = equivalent impervious area of all upstream areas on the property, in square metres

C_r = run-off coefficient, for a roofed area

A_r = total roofed catchment area, in square metres

C_i = run-off coefficient for an unroofed impervious (paved) area

A_i = total unroofed impervious (paved) catchment area, in square metres

C_p = run-off coefficient for an unroofed pervious (paved) area

A_p = total unroofed pervious catchment area, in square metres

In Australia, C_r and C_i are equal to 1.0 and 0.9, respectively (see Clause 5.4.6), and for Example 2 C_p is equal to 0.14 (see Paragraph K3.3.1(b)).

Column 7—gives for each section the cumulative equivalent impervious area (see Column 6 and Figure K2). This has to be determined by the designer, allowing for branching.

Column 8—gives for each section the design flow calculated from the following equation (see Clause 5.4.8 and Equation 5.4.8):

$$Q = \frac{\Sigma CA^5 I_5}{3600} \quad \dots \text{K3.3.2(2)}$$

where

Q = design flow, in litres per second

ΣCA = equivalent impervious area of all upstream areas on the property, in square metres

$^5 I_5$ = rainfall intensity for a duration of five minutes and an ARI of five years, in millimetres per hour

Column 9—gives for each section the selected minimum pipe diameter (see Clause 7.3.4).

Column 10—gives for each section the pipe gradient (see Clause 7.3.5) determined from Figure K2 and the minimum cover (see Clause 7.2.6).

Column 11—gives for each section the hydraulic capacity of the pipe determined from Figure 5.1(a) for the selected diameter (see Column 9) and adopted gradient (Column 10). The hydraulic capacity for each selected minimum diameter pipe is, in this example, significantly greater than design flow (see Column 8).

Column 12—gives for each section the full-pipe velocity for the design flow (see Column 8) calculated from the following equation:

$$v = \frac{4000Q}{\Pi d^2} \quad \dots \text{K3.3.2(3)}$$

where

v = full-pipe velocity, in metres per second

Q = design flow, in litres per second

d = diameter of the site stormwater drain, in millimetres

If, for other than steep gradients, the full-pipe velocity exceeds 1.5 m/s select a larger pipe diameter (see Column 9) and repeat Columns 10, 11 and 12.

Column 13—gives for each pit the minimum fall from the upstream to the downstream invert levels of 20 mm (see Clause 8.6.3).

Columns 14 and 15—give for each pit, downpipe outlet and junction the finished surface level determined in Figure K2.

Columns 16 and 17—give for each section the—

- (a) upstream invert level determined by—
 - (i) the minimum cover (see Clause 7.2.6); or
 - (ii) the fall along the immediate upstream section determined from the product of the length and gradient (see Columns 2 and 10); and
- (b) downstream invert level determined by—
 - (i) the minimum cover as for Item (a) (i); or
 - (ii) the minimum fall across a pit (see Column 13), provided that the upstream invert levels at—
 - (A) a junction are the same; and
 - (B) a pit are, where practicable, the same or the pipe with the higher invert level drops within the pit.

Columns 18 and 19—give for each section the upstream and downstream covers determined from the difference between the relevant surface level (see Columns 14 and 15) and invert level (see Columns 16 and 17) less the pipe diameter (see Column 9).

Before proceeding to the sizing of the next section check each cover for compliance with Clause 7.2.6 and, where necessary, increase the cover, by lowering the corresponding invert level, to satisfy this requirement.

The minimum internal dimensions of the pits shall comply with Table 8.2.

K4 EXAMPLE 3: GENERAL METHOD—WAREHOUSE

K4.1 Problem

A warehouse building with a plan area of 1344 m² is to be located in Penrith, New South Wales, on a property with an area of 2482 m² (73 m × 34 m) as shown in Figure K3. The property slopes to the street.

K4.2 Assumptions

It is assumed that—

- (a) overflow from the adjoining properties and Pits A and B will follow the overland flow path shown in Figure K3; and
- (b) the roof of the building falls to the east with the roof water collected at five vertical downpipes that discharge to the site stormwater drains connected to the street pit with an invert level of 13.00 m AHD.

K4.3 Solution

K4.3.1 Preliminary

Determine, for an ARI of two years, values for the following:

- (a) The rainfall intensity for a 5 min duration (5I_5) is 96 mm/h (see Clause 5.4.5(a)).
- (b) The run-off coefficient for the un-roofed pervious area (C_p) is $0.348 \times 0.85 = 0.30$ for a ${}^{10}I_{60}$ of 28.6 mm/h (see Equation 5.4.6 in Clause 5.4.6(a)). To allow for clay soils at the site, 0.1 is added, so $C_p = 0.30 + 0.10 = 0.40$

K4.3.2 Procedures

A trial surface water drainage system is shown in Figure K3. The site stormwater drains are to be of FRC pipes, having a roughness coefficient $k = 0.15$ mm.

Table K2 can be set up on a spreadsheet program that enables the automatic determination of the values shown in the shaded areas. The explanation of the application, but not the values for Example 2, given in Paragraph K3.3.2 are also applicable to Table K2.

In some cases the pipe diameter (see Column 9) and the cover (see Columns 18 and 19) could be reduced; however, since the clearance of blockages and replacement of pipes may be costly the preferred layout is shown in Figure K3.

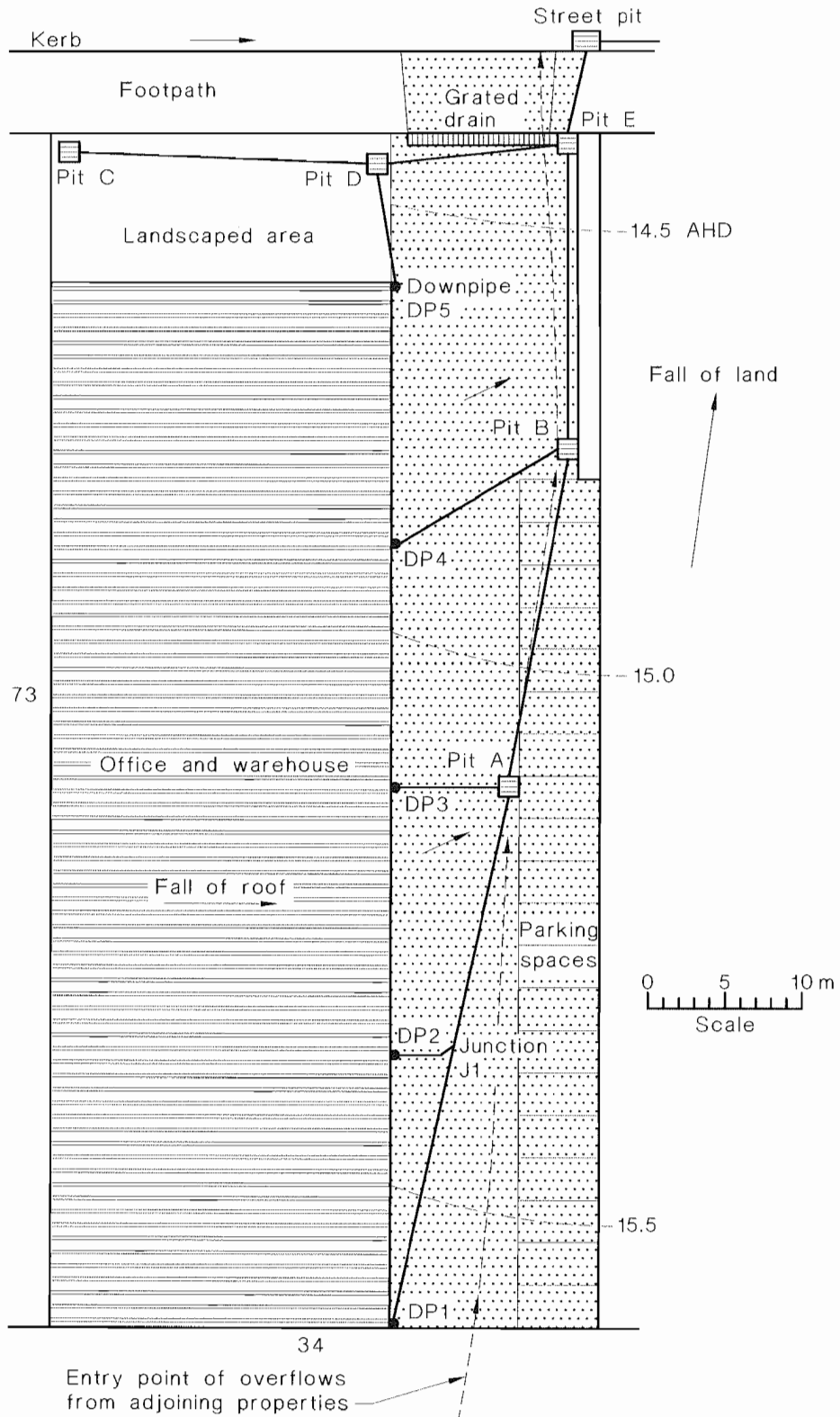

LEGEND:

- Downpipe, outlet = ●
- Stormwater pit = ■
- Site stormwater drain = —└

DIMENSIONS IN METRES

FIGURE K3 STORMWATER DRAINAGE INSTALLATION PLAN — EXAMPLE 3

TABLE K2
CALCULATION SHEET—EXAMPLE 3

| 1 | 2 | 3 | 4 | 5 | 6 | 7 | 8 | 9 | 10 | 11 | 12 | 13 | 14 | 15 | 16 | 17 | 18 | 19 |
|---------------------|--------|----------------|----------------|----------------|---|------------|--------------|------------|---------------|------------------|--------------------|--------------------------|-------------------|-------------------|------------|------------|--------------|--------------|
| Conduit | Length | Roof area | Paved area | Pervious area | Equivalent impervious area m ² | | Design flows | Pipe diam. | Pipe gradient | Pipe capacity | Full-pipe velocity | Min. fall across U/S pit | U/S surface level | D/S surface level | U/S invert | D/S invert | Cover m | |
| | | | | | Sub-catchment | Cumulative | | | | | | | | | | | U/S pipe end | D/S pipe end |
| | m | m ² | m ² | m ² | | | L/s | mm | 1:... | k=0.015 mm (L/s) | M/s | m | m | m | m | m | | |
| DP1 to J1 | 16.7 | 168 | 0 | 0 | 168 | 168 | 4.5 | 150 | 37 | 34 | 0.25 | NA | 15.60 | 15.35 | 15.25 | 14.80 | 0.20 | 0.40 |
| DP2 to J1 | 3.8 | 336 | 0 | 0 | 336 | 336 | 9.0 | 150 | 19.2 | 50 | 0.51 | NA | 15.35 | 15.35 | 15.00 | 14.80 | 0.10 | 0.40 |
| J1 to Pit A | 15.8 | 0 | 0 | 0 | 0 | 504 | 13.5 | 150 | 50 | 30 | 0.76 | 0.02 | 15.35 | 15.15 | 14.80 | 14.48 | 0.40 | 0.52 |
| DP3 to Pit A | 7.1 | 336 | 0 | 0 | 336 | 336 | 9.0 | 150 | 22 | 45 | 0.51 | NA | 15.15 | 15.15 | 14.80 | 14.48 | 0.20 | 0.52 |
| Pit A to Pit B | 19.6 | 0 | 403 | 0 | 363 | 1203 | 32.1 | 200 | 50 | 62 | 1.02 | 0.02 | 15.15 | 14.80 | 14.46 | 14.07 | 0.49 | 0.53 |
| DP4 to Pit B | 11.6 | 336 | 0 | 0 | 336 | 336 | 9.0 | 150 | 22 | 45 | 0.51 | NA | 14.95 | 14.80 | 14.60 | 14.07 | 0.20 | 0.58 |
| Pit B to Pit E | 20.8 | 0 | 260 | 0 | 234 | 1773 | 47.3 | 225 | 50 | 83 | 1.19 | 0.02 | 14.80 | 14.40 | 14.05 | 13.63 | 0.53 | 0.54 |
| Pit C to Pit D | 19.2 | 0 | 0 | 63 | 25 | 25 | 0.7 | 100 | 100 | 7 | 0.09 | NA | 14.50 | 14.48 | 14.20 | 14.01 | 0.20 | 0.37 |
| DP 5 to Pit D | 6.7 | 168 | 0 | 0 | 168 | 193 | 5.2 | 100 | 23 | 15 | 0.66 | NA | 14.60 | 14.48 | 14.30 | 14.01 | 0.20 | 0.37 |
| Pit D to Pit E | 11.3 | 0 | 0 | 126 | 50 | 243 | 6.5 | 150 | 31 | 37 | 0.37 | 0.02 | 14.48 | 14.40 | 13.99 | 13.63 | 0.34 | 0.62 |
| Pit E to Street Pit | 5.7 | 0 | 251 | 35 | 240 | 2256 | 60.2 | 225 | 25 | 120 | 1.51 | 0.02 | 14.40 | — | 13.61 | 13.38 | 0.57 | — |

Sums = 1344 914 224
 Total area = 2482 m²

LEGEND:

U/S = upstream
 D/S = downstream
 NA = not applicable

APPENDIX L
EXAMPLE CALCULATION—PUMPED SYSTEM

(Informative)

LOCATION—BRISBANE

Contributing area (A) = 1000 m² = 0.1 ha

ARI = 10 years

Storm period (T) = 120 min

Rainfall intensity (I) = 44.4 mm/h

Coefficient of run-off (C_{ro}) = 0.9

Peak discharge calculated using the rational method:

$$Q = C_{ro} \times I = 0.9 \times 44.4$$

$$Q = 39.96 \text{ (say 40 L/h/m}^2\text{)}$$

Volume for 2 h storm:

$$V = Q \times T \times A = (40 / 1000) \times 2 \times 1000 = 80 \text{ m}^3$$

ALTERNATIVE PUMP CAPACITY—WET WELL VOLUME COMBINATIONS

Site Area 1000 m²

Combined effective storage volume 80 m³

| Pump capacity (L/s) | Volume pumped in 30 min (m ³) | Required wet well volume (m ³) |
|------------------------|--|---|
| 40 | 72 | 10 |
| 30 | 54 | 26 |
| 20 | 36 | 44 |
| 10 (min) | 18 | 62 |

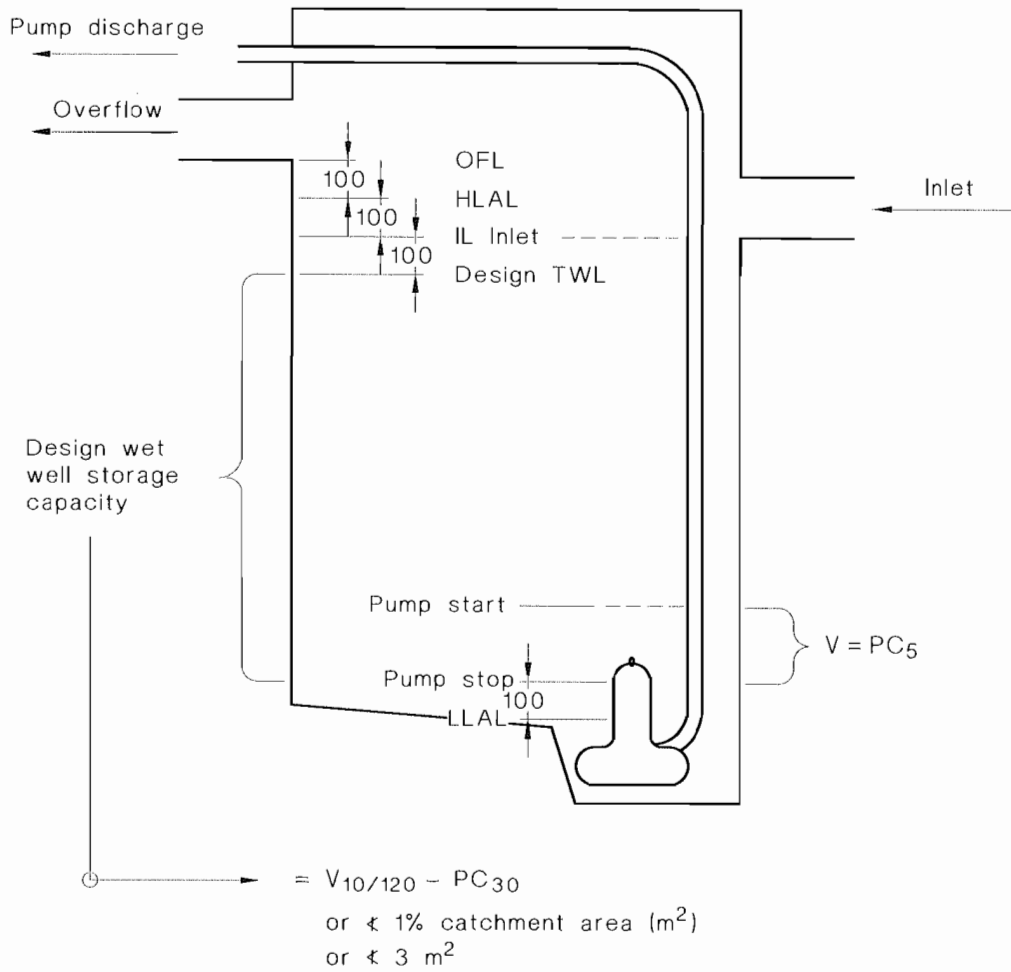

NOTES:

- OFL = Overflow level
- HLAL = High-level alarm level
- LLAL = Low-level alarm level
- $V_{10/120}$ = Volume in 10 year ARI, 120 minute storm
- PC_{30} = Pump capacity over 30 min
- PC_5 = Pump capacity over 5 min

DIMENSIONS IN MILLIMETRES

FIGURE L1 PUMP SYSTEM EXAMPLE

APPENDIX M
SUBSOIL DRAINAGE SYSTEMS—DESIGN
(Informative)

M1 SCOPE

This Appendix provides guidance for the design of subsoil drainage systems. Because decisions are dependent on particular site or soil conditions, detailed design of such systems is complex and, unless otherwise required to be authorized by the regulatory authority, should be undertaken with advice from a suitably qualified competent person.

NOTES:

- 1 This Appendix does not cover—
 - (a) the subsurface drainage of large areas of land, such as playing fields;
 - (b) systems for removal of stormwater by adsorption or infiltration into permeable soils; and
 - (c) drainage systems behind retaining walls.
- 2 An example of a suitable qualified competent person is a professional engineer specializing in geotechnical engineering.

M2 PURPOSE

The purpose of the subsoil systems covered in this Standard is to drain away ground water and, possibly, surface water in the vicinity of buildings in order to—

- (a) increase the stability of the ground and footings of buildings by inducing a more stable moisture regime and reducing foundation movements due to variations in the soil moisture content;
- (b) mitigate surface water ponding and waterlogging of soils by lowering watertables;
- (c) increase soil strength by reducing its moisture content; and
- (d) prevent damage, where applicable, due to frost heave of subsoil. (This generally applies to sites 1000 m or more above sea level.)

The investigation and design of subsoil drainage systems are uncertain processes. Only in a very limited number of situations can the need for subsoil drainage be identified without detailed subsurface investigations involving excavations, field observations and soil tests. One important factor indicating a need for subsoil drainage is the presence of a watertable high enough to have an adverse effect on the development.

In clay soils, subsoil drains can alter long-term soil moisture regimes so that building foundations are adversely affected by removing water, or in some cases by introducing water. In such conditions, subsoil drains should only be used where there are no other options for solving a dampness problem.

NOTE: Consideration should be given to the possible effects of intermittent or permanent reduction in ground water levels on adjacent lands. In soils with a clay content exceeding 20%, lowering watertables can cause soil shrinkage and damage to structures. AS 2870.1 recommends against placing subsoil drains too close to buildings on clayey sites.

M3 TYPES

The types of subsoil drains commonly used are shown in Figure M1. These may be installed on flat ground, in a sag or depression, or on sloping ground. The basic parts of a subsoil drain are shown in Figure M1(a)—a trench and fill or filter material, commonly sand or gravel. This simple arrangement is called a rubble drain or French drain.

Figure M1(b) shows the addition of a geotextile lining to prevent external fine soil particles being washed into the filter material and clogging it. Figure M1(c) shows the addition of a pipe to promote more rapid drainage. This is a typical subsoil drain. The pipe is perforated to allow easy entry of water and can be rigid or flexible. Figure M1(d) shows two further variations—an impervious cap for situations where the drain is intended to collect only subsurface flows, and bedding material for cases where the base of the excavation is unsuitable as a pipe support.

Figures M1(e), (f) and (g) show more elaboration. The pipe can be wrapped in geotextile to prevent piping and loss of filter material. Geocomposite drains of various configurations and manufacture can be provided. These are usually of plastic wrapped in geotextile and various proprietary systems are available. Finally, Figure M1(h) shows an external layer of filter material provided around the geotextile encompassing the filter material. This might be used where there is a likelihood of fine particles or deposits, e.g. iron precipitates, clogging the geotextile.

In general, subsoil drains connect into a pit, which is part of a surface water drainage system, with the subsoil drain pipe or strip drain penetrating the pit wall. Weepholes with a suitable geotextile filter may also be used to admit water from the filter materials into the pit.

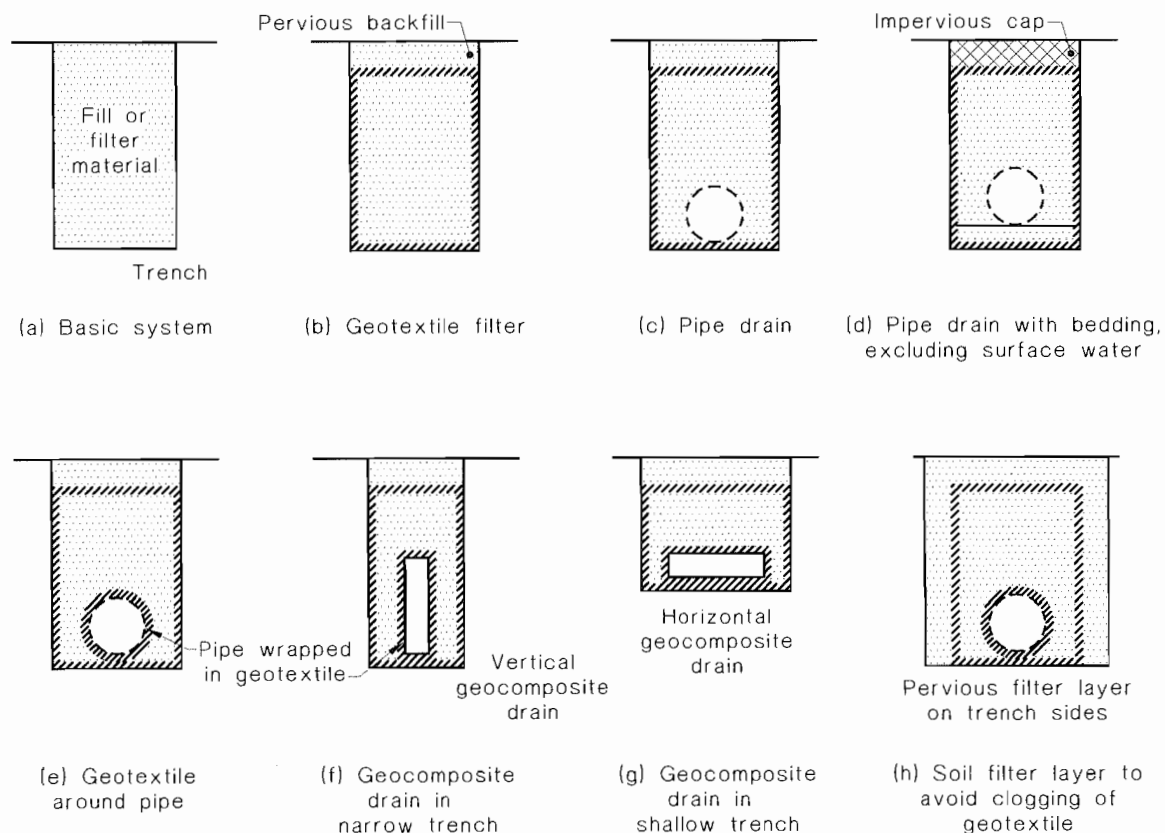

FIGURE M1 TYPES OF SUBSOIL DRAINS

M4 LAYOUT

M4.1 General arrangement

Relevant layouts for the types of subsoil drainage systems covered here include—

- subsoil drains on one or more sides of a building or cutting, including cut-off drains for interception of ground water flows from higher land; and

- (b) drainage systems for mitigating waterlogging or lowering watertables on small to medium areas of land, e.g. less than 500 m².

These may involve branch subsoil drains connecting to a main subsoil drain. Main subsoil drains often follow natural depressions.

The layout is directly related to the topography, the location of buildings and access points, the geology (nature of subsoil and level of ground water) and area of a property. Subsoil drains shall connect to a stormwater pit or a point of connection, and be consistent with the layouts for the site stormwater drain and the external stormwater drainage network.

Suggested maximum spacings for branch subsoil drains are as given in Table M1.

TABLE M1
SUGGESTED MAXIMUM SPACING OF BRANCH SUBSOIL DRAINS

| Soil type | Depth of invert of main subsoil drains | |
|------------|--|--------------|
| | 0.8 to 1.0 m | 1.0 to 1.5 m |
| | Maximum spacing, m | |
| Sand | — | 45 to 90 |
| Sandy loam | — | 30 to 45 |
| Loam | 16 to 20 | 20 to 30 |
| Clay loam | 12 to 16 | 15 to 20 |
| Sandy clay | 6 to 12 | — |
| Clay | 2 to 6 | — |

Source: BS 8301:1985

M4.2 Specifications—Drains

Subsoil drains should—

- (a) be laid with even gradients and straight runs, with a minimum number of changes to these and with any changes made at an appropriate fitting or at a pit;
- (b) have a cover as specified in Clause 7.2.6;
- (c) where under or in proximity to buildings, comply with Clause 7.2.9;
- (d) where in proximity to other services, comply with Clause 7.2.7;
- (e) be sized in accordance with Paragraph M5; and
- (f) have clean-out points, as specified in Clause 7.4.1(c).

M4.3 Specifications — Filters

Filter materials and geotextiles shall be as specified in Clause 2.13.

M5 DESIGN CONSIDERATIONS

M5.1 Drain dimensions and spacings

The depth of a subsoil drain is dictated by either the ground water conditions or the amount by which the ground water level is to be lowered. The following criteria are recommended:

- (a) Interceptor drains that aim to remove flows from a particular soil stratum or an aquifer should completely penetrate the stratum and should extend to a depth of 150 mm to 300 mm into the impervious strata below.
- (b) Where the subsoil drain is intended to lower the general ground water level, the determination of the depth of drain depends on whether there is a single or a multi-drain system as shown in Figure M2.

Analysis in these cases depends on knowledge of the hydraulic properties of the soil, and on theoretical solutions. A professional engineer with geotechnical expertise shall carry out the design work in critical cases.

For less critical situations, the drawdown curve for a single drain can be assumed to have the characteristics given in Table M2.

For multi-drain systems, the drain spacings given in Table M3 can be used in less critical applications.

Clay soils present particular problems as they may be too impermeable for any drawdown to occur and expert geotechnical advice should be sought.

- (c) Trench widths be a minimum of 300 mm where circular pipes are used. A minimum width of 450 mm is required where human access is required. Where a trench is deeper than 1.5 m, shoring as specified by relevant construction safety acts and regulations shall be used.

For geocomposite drains set vertically, as shown in Figure 6.1(f), the minimum trench width shall be 100 mm.

- (d) Drains be constructed with the base of the trench at an even slope, so that the trench acts as a rubble drain even if the pipe or geocomposite drain is blocked.
- (e) Where a subsoil drain pipe or geocomposite drain connects to a pit or a pump-out sump, there be access for easy inspection of flows so that the performance of the subsoil drain can be monitored. For drains in critical locations, a means of backflushing be provided to clear blockages.
- (f) Subsoil drains not be directly connected to street kerbs and gutters, or to street stormwater drains, in cases where backflow might cause damage.

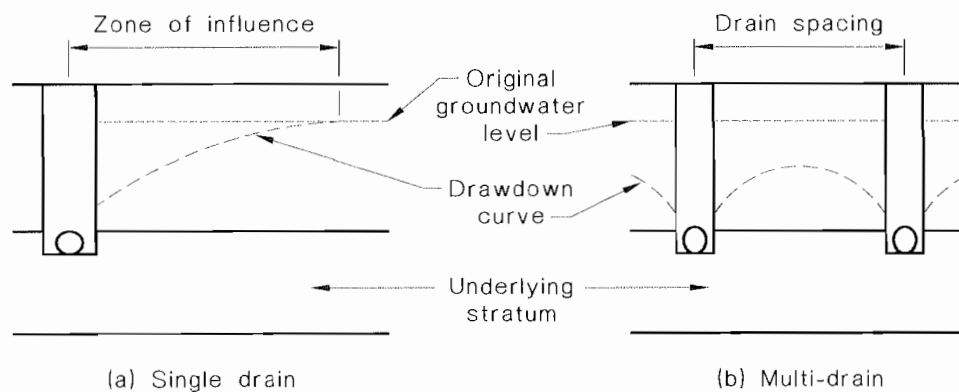

FIGURE M2 WATER TABLE DRAWDOWNS TO SINGLE AND MULTI-DRAIN SYSTEMS

TABLE M2
TYPICAL DRAWDOWN VALUES ASSOCIATED WITH A SINGLE DRAIN

| Soil type | Zone of influence m | Typical gradient of drawdown curve |
|---------------|------------------------|---------------------------------------|
| Coarse gravel | 150 | — |
| Medium gravel | 50 | 1:200 to 1:100 |
| Course sand | 40 | 1:100 to 1:33 |
| Medium sand | 15 to 30 | 1:50 to 1:20 |
| Fine sand | 8 to 15 | 1:20 to 1:5 |
| Silt/clay | Variable | 1:5 to 1:2.5 |

TABLE M3
TYPICAL DRAIN SPACINGS

| Soil type | Depth m | Spacing m |
|---------------------------------|------------|--------------|
| Sand | 1 to 2 | 50 to 90 |
| Sandy loam | 1 to 1.5 | 30 to 40 |
| Clay loam (i.e., a clayey silt) | 0.5 to 1 | 12 to 16 |

M5.2 Design of conduits

Pipes or other conduits associated with subsoil drains should meet the following criteria:

- (a) The size of conduits be related to the expected flows through them. These flows will be very small in fine-grained soils, but will be larger where—
 - (i) the drain is located in a pervious stratum such as a sand that is permanently fed by a nearby water body or by heavy rainfall over a prolonged period; or
 - (ii) the drain cuts off flow in an aquifer that is carrying a significant flow.
- (b) Where circular pipes are used in subsurface drains, normally, a minimum pipe size of DN 50 is employed, with larger sizes required for long runs of drains or in situation such as those described in Paragraph M5.2(a).

In cases of the larger flows described in Paragraph M5.2(a) advice shall be sought from a professional engineer with geotechnical expertise.

M5.3 Pipe gradient

The gradients of subsoil drains should be determined by the topography of the site rather than by consideration of self-cleansing velocities.

AMENDMENT CONTROL SHEET

AS/NZS 3500.3:2003

Amendment No. 1 (2006)

CORRECTION

SUMMARY: This Amendment applies to Clause 3.5.4, and Appendices E, I and J.

Published on 28 July 2006.

Amendment No. 2 (2010)

CORRECTION

SUMMARY: This Amendment applies to Clause 5.4.9(c), Equation 5.4.9 and Figure 7.3.

Published on 26 March 2010.

Standards Australia

Standards Australia is an independent company, limited by guarantee, which prepares and publishes most of the voluntary technical and commercial standards used in Australia. These standards are developed through an open process of consultation and consensus, in which all interested parties are invited to participate. Through a Memorandum of Understanding with the Commonwealth government, Standards Australia is recognized as Australia's peak national standards body.

Standards New Zealand

The first national Standards organization was created in New Zealand in 1932. The Standards Council of New Zealand is the national authority responsible for the production of Standards. Standards New Zealand is the trading arm of the Standards Council established under the Standards Act 1988.

Australian/New Zealand Standards

Under a Memorandum of Understanding between Standards Australia and Standards New Zealand, Australian/New Zealand Standards are prepared by committees of experts from industry, governments, consumers and other sectors. The requirements or recommendations contained in published Standards are a consensus of the views of representative interests and also take account of comments received from other sources. They reflect the latest scientific and industry experience. Australian/New Zealand Standards are kept under continuous review after publication and are updated regularly to take account of changing technology.

International Involvement

Standards Australia and Standards New Zealand are responsible for ensuring that the Australian and New Zealand viewpoints are considered in the formulation of international Standards and that the latest international experience is incorporated in national and Joint Standards. This role is vital in assisting local industry to compete in international markets. Both organizations are the national members of ISO (the International Organization for Standardization) and IEC (the International Electrotechnical Commission).

Visit our Web sites

www.standards.org.au

www.standards.co.nz



STANDARDS

NEW ZEALAND

PAEREWĀ AOTEAROA

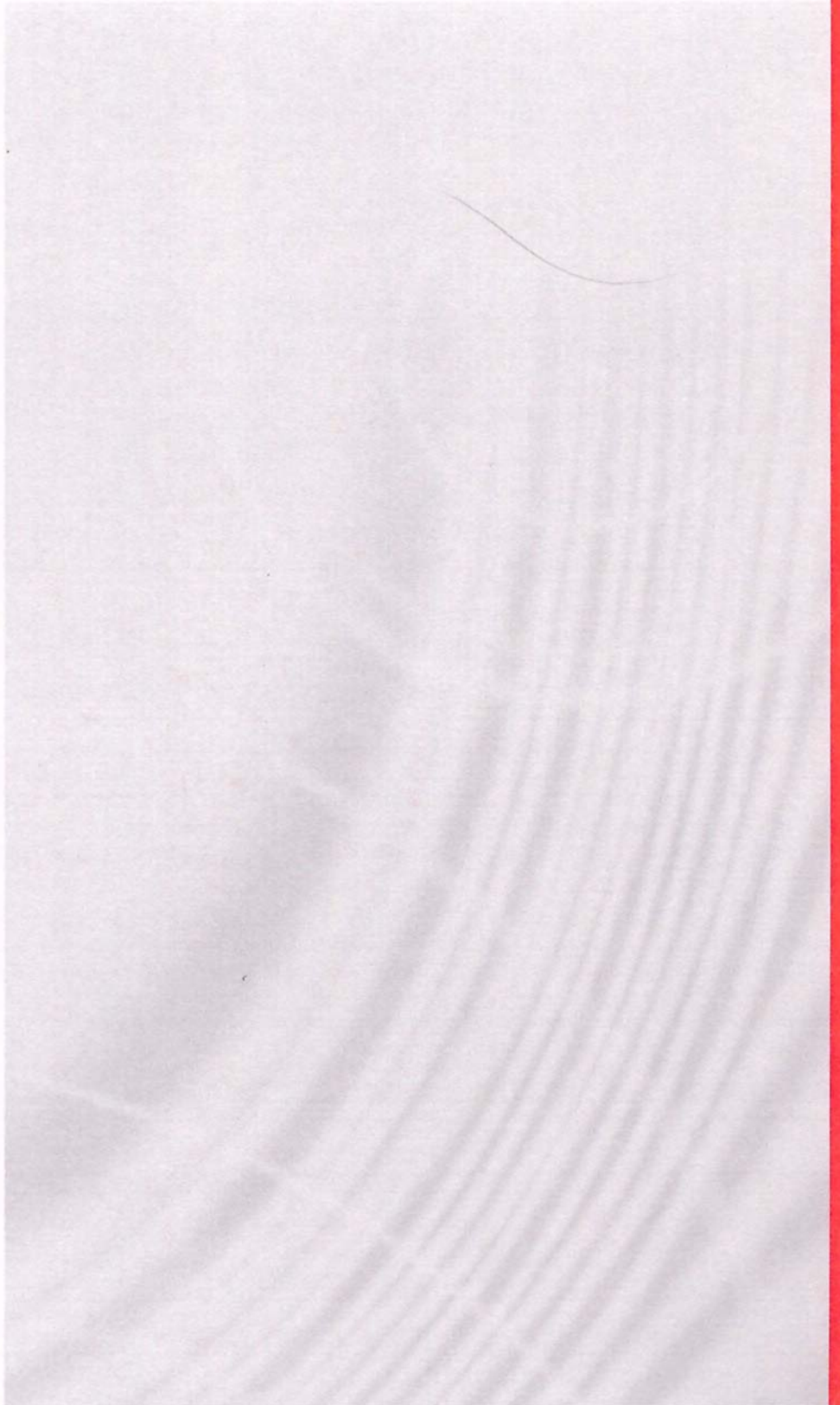

STANDARDS AUSTRALIA/STANDARDS NEW ZEALAND

Amendment No. 3
to
AS/NZS 3500.3:2003
Plumbing and drainage
Part 3: Stormwater drainage

REVISED TEXT

The 2003 edition of AS/NZS 3500.3 is amended as follows; the amendments should be inserted in the appropriate places.

SUMMARY: This Amendment applies Clauses 1.3.5, 2.4.1, 2.4.3, 4.4.4, 4.13.4 and 8.11.4, and Tables 4.2 and 4.3.

Published on 21 June 2012.

Approved for publication in New Zealand on behalf of the Standards Council of New Zealand on 8 June 2012.

AMDT
No. 3
JUN
2012

Clause 1.3.5

Delete existing definition and *replace* with the following:

A rainwater collection area whose dominant material has little or no effect on the chemical composition of rainwater draining from it. Such materials include acrylic, fibreglass, aluminium/zinc and aluminium/zinc/magnesium alloy-coated steel, glass, glazed tiles, unplasticized polyvinyl chloride and pre-painted metal.

AMDT
No. 3
JUN
2012

Clause 2.4.1

Delete the first paragraph and *replace* with the following:

Roof drainage system components made from aluminium alloys, aluminium/zinc and aluminium/zinc/magnesium alloy-coated steel, copper, copper alloys, zinc-coated steel, stainless steel and zinc shall comply with AS/NZS 2179.1.

AMDT
No. 3
JUN
2012

Clause 2.4.3

Delete existing text and notes and *replace* with the following:

Accessories and fasteners manufactured from aluminium alloys, aluminium/zinc and aluminium/zinc/magnesium alloy-coated steel, copper, copper alloys, zinc-coated steel, stainless steel and zinc shall comply with AS/NZS 2179.1.

AMDT
No. 3
JUN
2012

Clause 4.4.4

Delete existing text and *replace* with the following:

Bedding materials used in conjunction with roof drainage systems shall be chemically compatible. Cement-based bedding may be used between tiles and valley gutters other than those of exposed aluminium/zinc or aluminium/zinc/magnesium alloy-coated steel.

AMDT
No. 3
JUN
2012

Table 4.2

Delete existing Table, Legend and Notes, and *replace* with the following:

| Roof drainage system components and any cladding material | Accessory or fastener material | | | | | | | | | | | | Fastener material | |
|--|--------------------------------|------|---------------------------|------|------------------------------|------|----------------------------|------|--|------|-----------|------|---------------------------|------|
| | Aluminium alloys | | Copper and copper alloys* | | Stainless steel (300 series) | | Zinc-coated steel and zinc | | Aluminium/zinc and aluminium/zinc/magnesium alloy-coated steel | | Lead | | Ceramic or organic coated | |
| | Atmospheric classification | | | | | | | | | | | | | |
| | SI and VS | Mild | SI and VS | Mild | SI and VS | Mild | SI and VS | Mild | SI and VS | Mild | SI and VS | Mild | SI and VS | Mild |
| Aluminium alloys | Yes | Yes | No | No | † | Yes | ‡ | ‡ | Yes | Yes | No | No | Yes | |
| Copper and copper alloys | No | No | Yes | Yes | No | Yes | No | No | No | No | No | Yes | Yes | |
| Stainless steel (300 series) | No | No | No | No | Yes | Yes | No | No | No | No | No | Yes | Yes | |
| Zinc-coated steel and zinc | Yes | Yes | No | No | No | Yes | Yes | Yes | Yes | Yes | No | Yes | Yes | |
| Aluminium/zinc and aluminium/zinc/magnesium alloy-coated steel | Yes | Yes | No | No | No | Yes | ‡ | ‡ | Yes | Yes | No | No | Yes | |
| Lead § | No | No | Yes | Yes | Yes | Yes | No | Yes | No | No | Yes | Yes | Yes | |

* Includes monel metal rivets.

† Grade 316 in accordance with ASTM A240 is suitable.

‡ Unpainted zinc-coated steel and zinc are suitable for direct contact but should not receive drainage from an inert catchment.

§ Due to its toxicity, lead is not recommended for rainwater goods.

LEGEND:

SI, VS, Mild = severe industrial, very severe and mild classifications (see AS/NZS 2312).

Yes = acceptable—as a result of bimetallic contact, either no additional corrosion of rainwater goods will take place, or at the worst, only very slight additional corrosion. It also implies that the degree of corrosion would not significantly shorten the service life.

No = not acceptable—moderate to severe corrosion of rainwater goods will occur, a condition which may result in a significant reduction in the service life.

NOTE: Unless adequate separation can be assured, prepainted rainwater goods should be considered in terms of the base metal or coated metal product.

file, the one permitted printed copy of this PDF file, or any part of either of them.

You undertake that you will not modify, adapt, translate, reverse engineer, decompile, disassemble or create derivative works based on any of the downloaded PDF file, nor will you merge it with any other software or document, even for internal use within your organization.

Under no circumstances may this PDF file be placed on a network of any sort without the express permission of Standards New Zealand.

You are solely responsible for the selection of this PDF file and any advice or recommendation given by Standards New Zealand or its employees or agents about any aspect of this PDF file is intended for guidance only and is followed or acted upon entirely at your own risk.

Standards New Zealand is not aware of any inherent risk of viruses in this PDF file at the time that it is downloaded. Standards New Zealand has exercised due diligence to ensure, so far as practicable, that this file does not contain such viruses.

No warranty of any form is given by Standards New Zealand or by any party associated with Standards New Zealand with regard to this PDF file, and you accept and acknowledge that Standards New Zealand will not be liable in any way to you or any to other person in respect of any loss or damage, however caused which may be suffered or incurred or which may arise directly or indirectly through any use of this PDF file.

Regardless of where you were when you downloaded this PDF file you accept and acknowledge that to the fullest extent possible you submit to New Zealand law with regard to this licence and to your use of this PDF file.

Copyright Standards New Zealand *

Copyright Standards New Zealand *

Table 4.3

Delete existing Table, Legend and Notes, and *replace* with the following:

| Lower roof drainage system material | Upper cladding or roof drainage system material | | | | | | | | | | |
|--|---|--------------------------|------------------------------|----------------------------|--|------|------------------|------------|----------|---------|-------|
| | Aluminium alloys | Copper and copper alloys | Stainless steel (300 series) | Zinc-coated steel and zinc | Aluminium/zinc and aluminium/zinc/magnesium alloy-coated steel | Lead | Prepainted metal | Roof tiles | | Plastic | Glass |
| | | | | | | | | Glazed | Unglazed | | |
| Aluminium alloys | Yes | No | * | Yes | Yes | * | Yes | Yes | Yes | Yes | Yes |
| Copper and copper alloys | * | Yes | * | * | * | Yes | * | Yes | Yes | Yes | Yes |
| Stainless steel (300 series) | * | * | Yes | * | * | Yes | * | Yes | Yes | Yes | Yes |
| Zinc-coated steel and zinc | No | No | No | Yes | No | * | No | No | Yes | No | No |
| Aluminium/zinc and aluminium/zinc/magnesium alloy-coated steel | Yes | No | * | Yes | Yes | No | Yes | Yes | Yes | Yes | Yes |
| Lead | * | * | * | * | * | Yes | * | Yes | Yes | Yes | Yes |

* Whilst drainage between the materials shown would be acceptable, direct material contact should be avoided (see Table 4.2).

LEGEND:

Yes = acceptable

No = not acceptable

NOTE: 'Acceptable' and 'not acceptable' imply similar performances to those noted in Table 4.2.

AMDT
No. 3
JUN
2012

Clause 4.13.4

Delete Clause heading and text and *replace* with the following:

4.13.4 Aluminium/zinc and aluminium/zinc/magnesium alloy-coated steel

Aluminium/zinc and aluminium/zinc/magnesium alloy-coated steel components, including accessories, shall be jointed with sealant joints and fasteners as specified in Clause 4.13.1.2.

AMDT
No. 3
JUN
2012

Clause 8.11.4

Delete existing text and *replace* with the following:

Storages shall be constructed of concrete, masonry, aluminium/zinc and aluminium/zinc/magnesium alloy-coated steel, zinc-coated steel, galvanized iron or plastics.
