



MAINTENANCE

Regular maintenance is essential to maintain the good looks of all Stratco steel products and to ensure you receive the maximum lifespan possible. Washing with clean water must be frequent enough to prevent the accumulation of dust, salts, and pollutants that may reduce the life of the product. Stratco steel products that are regularly washed by rain require no additional maintenance. No Stratco steel structure or materials are recommended for use over, or in close proximity, to swimming pools or spas. No material that retains water (such as dirt or paving sand) should be placed against the columns. Care must be taken when determining the location of Stratco steel products so that they are not placed in close contact with sources of pollution or environmental factors that could affect the life of the steel. Refer to the 'Selection, Use and Maintenance' brochure for more information.



Outback[®] Riser Bracket

VERANDAHS | PATIOS | CARPORTS



BEFORE YOU START

Please read these assembly instructions thoroughly before commencing the construction.

Double check all dimensions, levels and bolting locations before cutting, screwing or bolting structural members. It is recommended that the persons erecting the structure have previous building experience because modifications to the existing house structure will be required.

It is the builder's responsibility to ensure that the existing house roof structure is adequately strengthened to accommodate the additional loads imposed by the verandah, patio or carport.

For more information regarding the suitability of the house structure, consult a structural engineer or a building authority.

TOOLS REQUIRED



INSTALLATION

The first objective in the construction is to fix the Riser Brackets through the fascia and attach to the house rafter.

Determine the number of rafters which need to be strengthened and their location relative to the unit. You will have to lift some roof tiles or roof sheets to discover the rafter positions and spacings. The number of rafters which need to be strengthened is determined by the builder, however spacing is recommended not to exceed 1200mm.

Note: It is the builder's responsibility to ensure the existing rafters and fascia are adequately reinforced and strengthened to accommodate any additional attached structure. The reinforcing method must be approved by the appropriate council or engineer. It is recommended a Riser Bracket is used in conjunction with an extension channel, as shown in Figure 1.

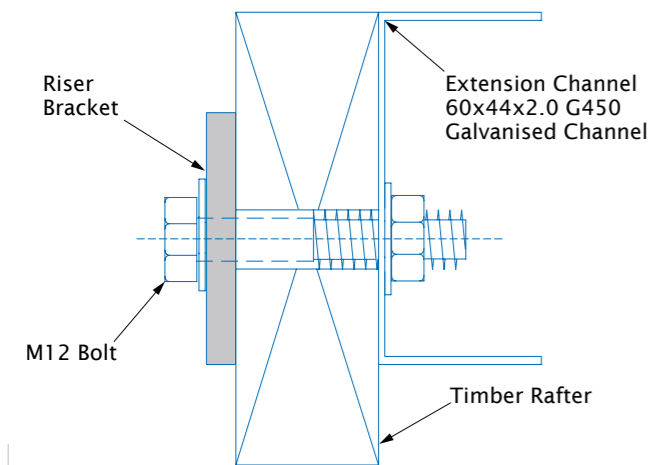

Figure 1

The 22° Riser Bracket has been designed to cover roof pitches from 20°, and up to 25°, while the 27° Riser Bracket will cover roof pitches from 25° up to 30° (Figure 2). A channel is fixed to the side of the house rafter in conjunction with the Riser Brackets (Figure 1). The bottom end of the extension channel will be located at the eave end of the house rafter.

Holes should be marked and pre-drilled in the extension channel to suit the location of existing holes in the Riser Bracket. The extension channel will extend beyond the bracket so additional holes are to be drilled in the channel at approximately 500mm centres.

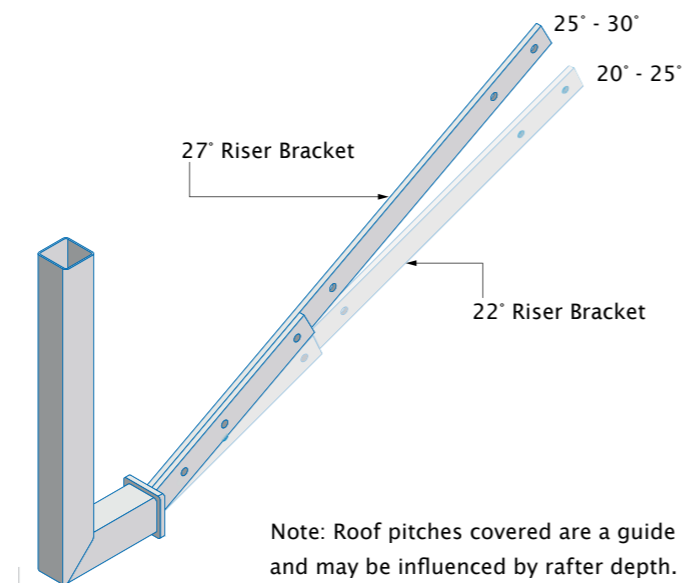

Figure 2

Mark the position of the Riser Brackets on the fascia. Notch a rectangular hole in the fascia allowing the bracket to be fed through the front of the fascia.

Mount the extreme end Riser Brackets first, so the internal Riser Brackets are lined up with the external vertical and horizontal faces of the Riser Brackets (Figure 3). The Riser Brackets should be mounted as close to the gutter as possible (recommended distance 10mm from lowest end of gutter, refer to Figure 4). The position will also be determined by the internal end of the Riser Bracket and its position on the roof rafter (Figure 4). Make sure there is sufficient material around the mounting bolts for a strong connection. If there is a difference of angle between the roof rafter and the Riser Bracket, make sure all connection points are suitable, while the external vertical face of the Riser Bracket is vertical to the ground.

INSTALLATION

The vertical height of the Riser Brackets is 600mm and may need to be reduced, depending on the total height requirement of the verandah. If this is to be reduced, mark a cut off point on one of the end brackets and remove the brackets for cutting. Make sure all the brackets are cut to the same dimension, so the attachment beam which mounts into the end of the Riser Bracket will be level.

Clamp the Riser Bracket to the roof rafter initially. Run a string line along the bottom face of the end Riser Brackets so the external face of the Riser Bracket can be checked with a spirit level to ensure it is vertical. Insert the internal Riser Brackets into the holes on the fascia and clamp to the roof rafter, ensuring the brackets are vertical and positioned against the horizontal string line (Figure 3).

Fix the brackets and channels to the roof rafters using M12 hex head bolts, in all the Riser Brackets and extension channel holes.

65mm Inline Beam Connectors are attached to the top of the tube section of the Riser Brackets and fastened using two 12x20mm self drilling screws, refer to Figure 3.

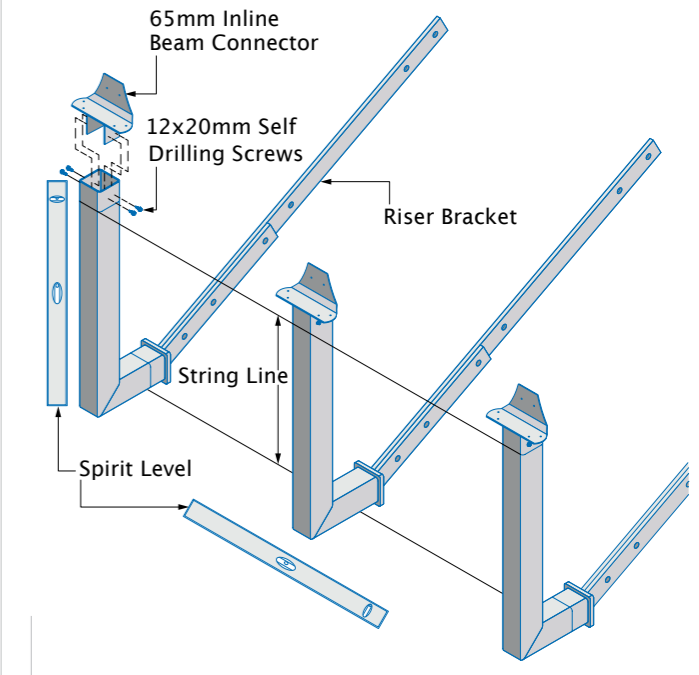

Figure 3

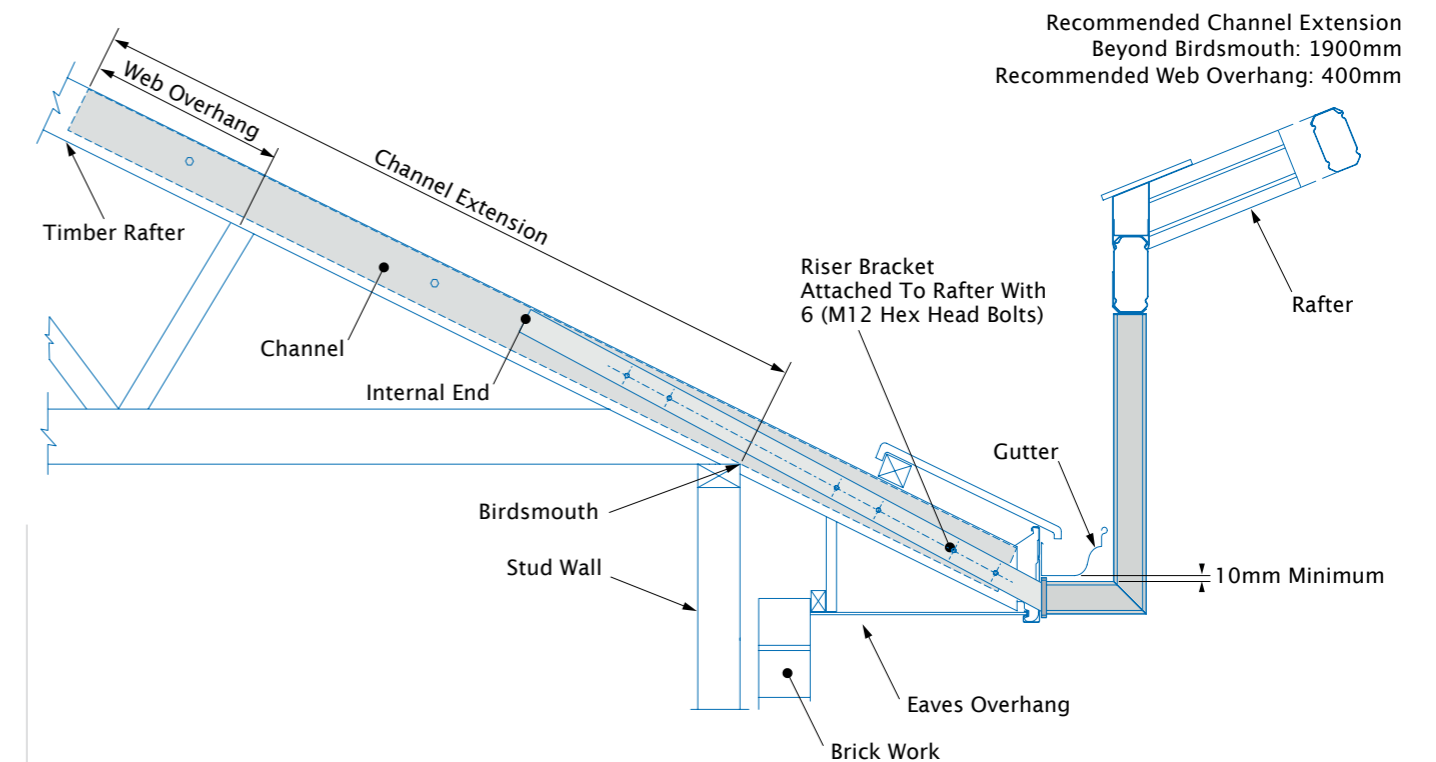

Figure 4